

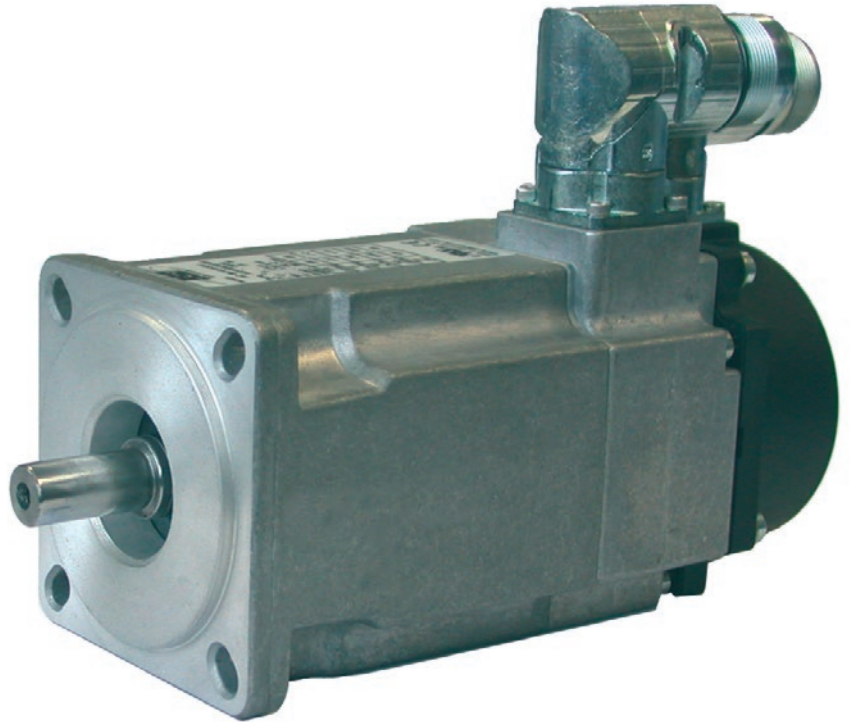

aerospace  
climate control  
**electromechanical**  
filtration  
fluid & gas handling  
hydraulics  
pneumatics  
process control  
sealing & shielding



## NX Series

Low Cogging Servo Motor



ENGINEERING YOUR SUCCESS.



**WARNING – USER RESPONSIBILITY**

**FAILURE OR IMPROPER SELECTION OR IMPROPER USE OF THE PRODUCTS DESCRIBED HEREIN OR RELATED ITEMS CAN CAUSE DEATH, PERSONAL INJURY AND PROPERTY DAMAGE.**

- This document and other information from Parker-Hannifin Corporation, its subsidiaries and authorized distributors provide product or system options for further investigation by users having technical expertise.
- The user, through its own analysis and testing, is solely responsible for making the final selection of the system and components and assuring that all performance, endurance, maintenance, safety and warning requirements of the application are met. The user must analyze all aspects of the application, follow applicable industry standards, and follow the information concerning the product in the current product catalog and in any other materials provided from Parker or its subsidiaries or authorized distributors.
- To the extent that Parker or its subsidiaries or authorized distributors provide component or system options based upon data or specifications provided by the user, the user is responsible for determining that such data and specifications are suitable and sufficient for all applications and reasonably foreseeable uses of the components or systems.

<b>Overview .....</b>	<b>5</b>
<b>NX1-NX2 CE Motors .....</b>	<b>6</b>
Dimensions .....	7
Order Code .....	8
<b>NX1-NX2 UL Motors .....</b>	<b>9</b>
Dimensions .....	10
Order Code .....	11
<b>NX3-NX8 CE and UL Motors .....</b>	<b>12</b>
Technical Data .....	12
Dimensions .....	15
Order Code .....	17
<b>Accessories and Options .....</b>	<b>18</b>
Cables.....	18
Holding Brake .....	19
Feedback .....	19

# Parker Hannifin

## The global leader in motion and control technologies

### A world class player on a local stage

#### Global Product Design

Parker Hannifin has more than 40 years experience in the design and manufacturing of drives, controls, motors and mechanical products. With dedicated global product development teams, Parker draws on industry-leading technological leadership and experience from engineering teams in Europe, North America and Asia.

#### Local Application Expertise

Parker has local engineering resources committed to adapting and applying our current products and technologies to best fit our customers' needs.

#### Manufacturing to Meet Our Customers' Needs

Parker is committed to meeting the increasing service demands that our customers require to succeed in the global industrial market. Parker's manufacturing teams seek continuous improvement through the implementation of lean manufacturing methods throughout the process. We measure ourselves on meeting our customers' expectations of quality and delivery, not just our own. In order to meet these expectations, Parker operates and continues to invest in our manufacturing facilities in Europe, North America and Asia.

#### Electromechanical Worldwide Manufacturing Locations

##### Europe

Littlehampton, United Kingdom  
Dijon, France  
Offenburg, Germany  
Filderstadt, Germany  
Milan, Italy

##### Asia

Wuxi, China  
Jangan, Korea  
Chennai, India

##### North America

Rohnert Park, California  
Irwin, Pennsylvania  
Charlotte, North Carolina  
New Ulm, Minnesota



Offenburg, Germany

#### Local Manufacturing and Support in Europe

Parker provides sales assistance and local technical support through a network of dedicated sales teams and authorized technical distributors throughout Europe.

For contact information, please refer to the Sales Offices on the back cover of this document or visit [www.parker.com](http://www.parker.com)



Milan, Italy



Littlehampton, UK



Filderstadt, Germany



Dijon, France

# Low Cogging Servo Motor - NX Series

## Overview

### Description

NX Series brushless servomotors from Parker combine exceptional precision and motion quality, high dynamic performance and very compact dimensions. A large set of torque / speed characteristics, options and customization possibilities are available, making NX Series servomotors the ideal solution for most servosystems applications.

### Advantages

- High precision and motion quality
- High dynamic performance
- Compact robust
- Large set of options and customization possibilities
- CE and UL marking certification available

### Applications

- Life Science Diagnostic
- Tooling Machines
- Pulp & Paper
- Renewable Energy
- Aerospace
- Radiation Hardend
- Marine
- Continuous Process
- Mobile Hybrid Solutions

### Features

- **Mounting**
  - Flange with clearance holes
- **Shaft end**
  - Plain smooth shaft (standard)
  - Plain keyed shaft (option)
- **Cooling**
  - Natural ventilation
  - Forced ventilation (NX860V only)
- **Feedback sensors**
  - Resolver (standard)
  - Absolute EnDat or Hiperface encoder
  - Incremental encoder
- **Other options**
  - Brake
  - Thermal protection (PTC, Thermo Switch or KTY)

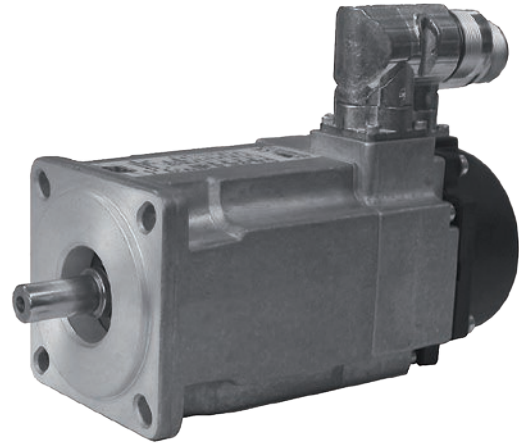

### Technical Characteristics - Overview

<b>Motor type</b>	Permanent magnet synchronous servomotors	
<b>Rotor design</b>	Rotor with concentrated-flux rare earth magnets	
<b>Number of poles</b>	10	
<b>Power range</b>	0.2...13.7 kW	
<b>Torque range</b>	0.45...64 Nm	
<b>Speed range</b>	0...7500 min <sup>-1</sup>	
<b>Protection level (IEC60034-5)</b>	<ul style="list-style-type: none"> <li>• IP64 (standard)</li> <li>• IP65 (option)</li> <li>• IP44 (ventilated version)</li> </ul>	
<b>Marking</b>	CE	UL
<b>Voltage supply</b>	230/400 VAC	230/480 VAC
<b>Temperature class (IEC60034-1)</b>	<ul style="list-style-type: none"> <li>• Class F</li> </ul>	<ul style="list-style-type: none"> <li>• Class A (NX1-2)</li> <li>• Class F (NX3-8)</li> </ul>
<b>Connections</b>	<ul style="list-style-type: none"> <li>• Connectors (standard)</li> <li>• Flying cables (option)</li> <li>• Terminal box (option)</li> </ul>	<ul style="list-style-type: none"> <li>• Connectors (NX1-8)</li> <li>• Terminal box (NX860V)</li> </ul>

# NX1-NX2 CE Motors

## Technical Data

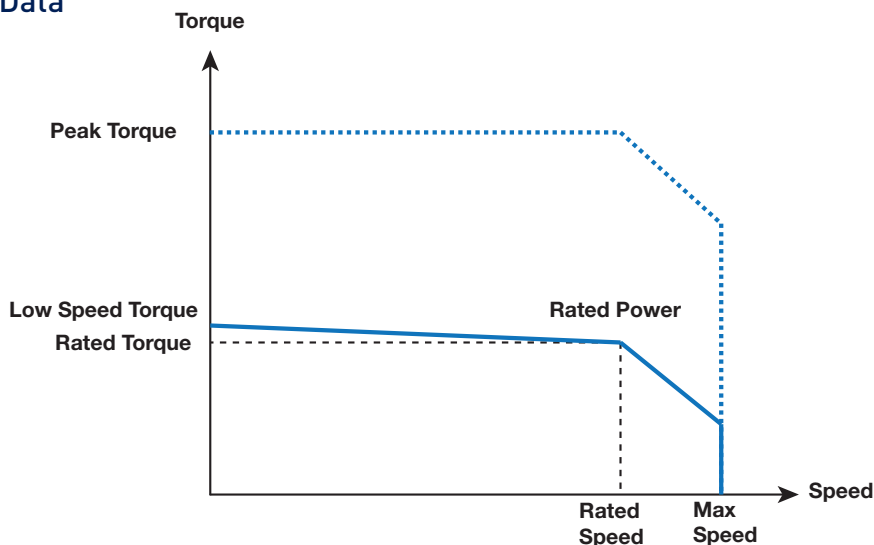

Model	Size	Stall <sup>(1)</sup>		Nominal <sup>(1)</sup>			Peak <sup>(1)</sup>	Inertia		Ke <sup>(2) (3)</sup>	Kt <sup>(2) (3)</sup>
		Torque	Current	Torque	Speed	Current	Torque	No brake	With brake		
		T <sub>0</sub> [Nm]	I <sub>0</sub> [A]	T <sub>n</sub> [Nm]	n [min <sup>-1</sup> ]	I <sub>n</sub> [A]	T <sub>max</sub> [Nm]	J [kgmm <sup>2</sup> ]	J [kgmm <sup>2</sup> ]	Ke [Vs]	Kt [Nm/A <sub>rms</sub> ]
<b>230 VAC power supply</b>											
NX110EAP	42.5	0.45	1.0	0.33	6000	0.79	1.7	13	14	29.9	0.455
NX205EAV		0.45	1.0	0.37	5000	0.86	2.0	21	33	30.2	0.444
NX205EAS	56.5	0.45	1.4	0.29	7500	0.96	2.0	21	33	21.9	0.322
NX210EAT		1	1.3	0.80	4000	1.11	3.4	38	50	48.6	0.749
NX210EAP		1	2.0	0.61	6000	1.32	3.4	38	50	32.6	0.503
<b>400 VAC power supply</b>											
NX205EAV	56.5	0.45	1.0	0.29	7500	0.69	2.0	21	33	30.2	0.444
NX205EAS		0.45	1.4	0.229	8900	0.8	2.0	21	33	21.9	0.322
NX210EAT		1	1.3	0.613	6000	0.9	3.4	38	50	48.6	0.749
NX210EAP		1	2.0	0.499	7000	1.1	3.4	38	50	32.6	0.503

<sup>(1)</sup> Data referred to motor mounted on aluminium flange: 280 x 280 x 8 mm (NX1-2), Temperature <40 °C near motor's flange. Stall torques refer to motor turning at 100 min<sup>-1</sup>  
<sup>(2)</sup> Data measured at 20 °C. When "hot" consider -0.09 %/K derating  
<sup>(3)</sup> Manufacturing tolerance data ±10 %

Motor	Associated Drive Sizes					AC30
	PSD1S <sup>(2)</sup>	PSD1M	Compax3	SLVD-N	AC890	
<b>230 VAC power supply</b>						
NX110EAP	PSD1SW1200...	PSD1MW3222...	C3S025V2...	SLVD1N...	-	-
NX205EAV	PSD1SW1200...	PSD1MW3222...	C3S025V2...	SLVD1N...	890SD-231300B...	-
NX205EAS	PSD1SW1200...	PSD1MW3222...	C3S025V2...	SLVD2N...	890SD-231300B...	-
NX210EAT	PSD1SW1200...	PSD1MW3222...	C3S025V2...	SLVD2N...	890SD-231300B...	-
NX210EAP	PSD1SW1200...	PSD1MW3222...	C3S025V2...	SLVD2N...	890SD-231300B...	-
<b>400 VAC power supply</b>						
NX205EAV	-	PSD1MW1300...	C3S015V4...	-	890SD-531200B...	31V-4D-0004
NX205EAS	-	PSD1MW1300...	C3S015V4...	-	890SD-531200B...	31V-4D-0004
NX210EAT	-	PSD1MW1300...	C3S015V4...	-	890SD-531200B...	31V-4D-0004
NX210EAP	-	PSD1MW1300...	C3S015V4...	-	890SD-531200B...	31V-4D-0004

## Dimensions

Motor	A	Mounting Flange centering / interaxis hole	Shaft diameter x length	Without Brake		With Brake		Fr*	Fa*
	[mm]			[mm]	L [mm]	Weight [kg]	L [mm]		
NX110	42.5	30 / 50	9 x 25	110	0.8	141	141	15	6.9
NX205	56.5	40 / 63	11 x 25	100	0.8	137	137	28	15.5
NX210				120	1.3	157	157	30	16.7

\* Fr and Fa not cumulative: At 1500 min<sup>-1</sup> for a bearing service life of 20000 hours

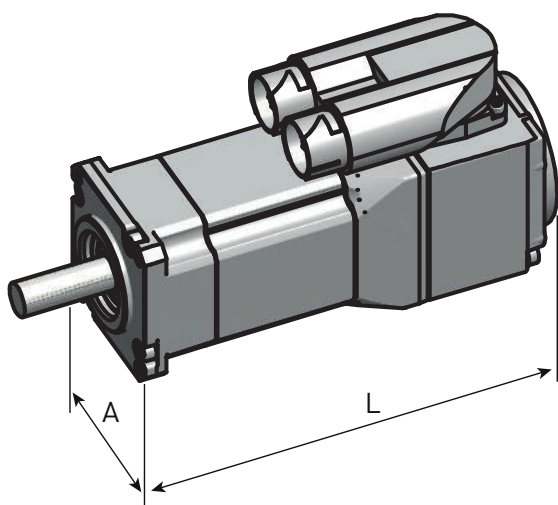

NX1

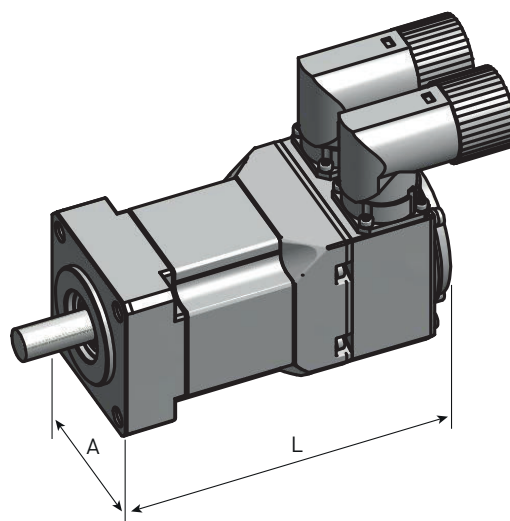

NX2

## Order Code

### NX1, NX2, CE - Natural Cooling Version

	1	2	3	4	5	6	7	8
Order example	<b>NX110E</b>	<b>A</b>	<b>P</b>	<b>R</b>	<b>7</b>	<b>0</b>	<b>1</b>	<b>0</b>

<b>1 Motor type</b>	<b>NX110E</b> see table NX1-NX2 CE Motors "Technical data"
	<b>NX205E</b>
	<b>NX210E</b>
<b>2 Feedback sensor *</b>	
<b>A</b>	2 pole resolver (standard)
<b>Y</b>	Without sensor
<b>R</b>	Absolute single-turn HIPERFACE encoder 128 ppr SKS36 (NX2 only)
<b>S</b>	Absolute multi-turn HIPERFACE encoder 128 ppr SKM36 (NX2 only)
<b>X</b>	Commutated lines 10 poles – 2048pulses (NX2 only)
<b>3 Motor type</b>	
<b>P</b>	see table NX1-NX2 CE Motors "Technical data"
<b>V</b>	
<b>S</b>	
<b>...</b>	
<b>4 Painting</b>	
<b>R</b>	Unpainted (standard)
<b>B</b>	Black mat (on request)
<b>5 Connections</b>	
<b>1</b>	Flying cables (option)
<b>4</b>	Flying cables with shielded sleeve (option)
<b>7</b>	Connectors (standard)
<b>6 Brake</b>	
<b>0</b>	Without brake
<b>3</b>	With brake
<b>7 Protection degree</b>	
<b>0</b>	IP64 (standard)
<b>1</b>	IP65
<b>8 Shaft end</b>	
<b>0</b>	Smooth shaft (standard)
<b>1</b>	Keyed shaft

\* other types of feedback sensor are available on request



# NX1-NX2 UL Motors

## Technical Data

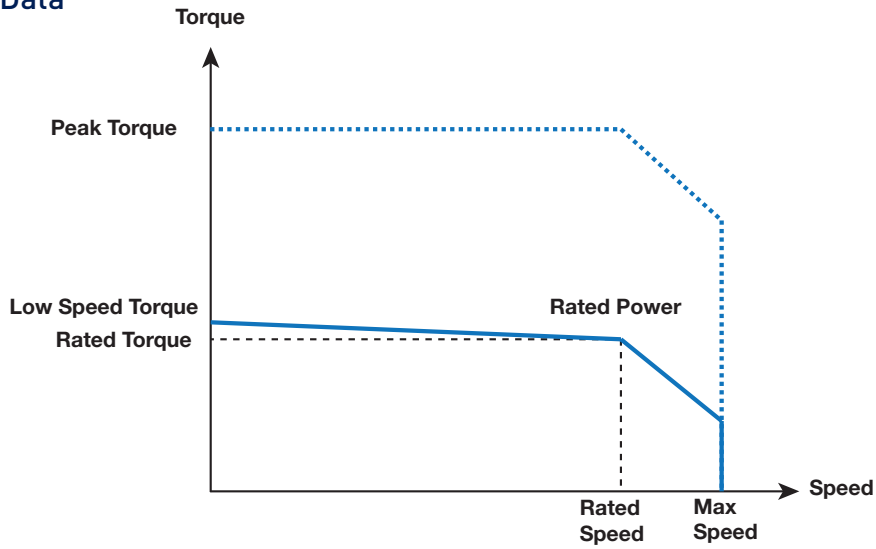

Model	Size	Stall <sup>(1)</sup>		Nominal <sup>(1)</sup>			Peak <sup>(1)</sup>	Inertia		Ke <sup>(2) (3)</sup>	Kt <sup>(2) (3)</sup>
		Torque	Current	Torque	Speed	Current	Torque	No brake	With brake		
		T <sub>0</sub> [Nm]	I <sub>0</sub> [A]	T <sub>n</sub> [Nm]	n [min <sup>-1</sup> ]	I <sub>n</sub> [A]	T <sub>max</sub> [Nm]	J [kgmm <sup>2</sup> ]	J [kgmm <sup>2</sup> ]	Ke [Vs]	Kt [Nm/A <sub>rms</sub> ]
<b>230 VAC supply voltage - mono or three-phased</b>											
NX110AAJ	42.5	0.31	1.0	0.09	5000	0.34	0.9	13	14	22.4	0.318
NX210AAT	56.5	0.7	1.0	0.41	4000	0.61	1.9	38	50	48.6	0.701
<b>480 VAC supply voltage - three-phased</b>											
NX210AAT	56.5	0.7	1.0	0.154	6000	0.3	1.9	38	50	48.6	0.701

<sup>(1)</sup> Data referred to motor mounted on aluminium flange: 280 x 280 x 8 mm (NX1-2), Temperature <40 °C near motor's flange. Stall torques refer to motor turning at 100 min<sup>-1</sup>

<sup>(2)</sup> Data measured at 20 °C. When "hot" consider -0.09 %/K derating

<sup>(3)</sup> Manufacturing tolerance data ±10 %

Motor	Associated Drive Sizes					AC30
	PSD1S <sup>(2)</sup>	PSD1M	Compax3	SLVD-N	AC890	
<b>230 VAC supply voltage - mono or three-phased</b>						
NX110AAJ	PSD1SW1200...	PSD1MW3222...	C3S025V2...	SLVD1N...	-	-
NX210AAT	PSD1SW1200...	PSD1MW3222...	C3S025V2...	SLVD1N...	890SD-231300B...	-
<b>480 VAC supply voltage - three-phased</b>						
NX210AAT	-	PSD1MW1300...	C3S015V4...	-	890SD-531200B...	31V-4D-0004

## Dimensions

Motor	A	Mounting Flange centering / interaxis hole	Shaft diameter x length	Without Brake		With Brake		Fr* [daN]	Fa* [daN]
	[mm]			[mm]	L [mm]	Weight [kg]	L [mm]		
NX110	42.5	30 / 50	9 x 25	134	0.8	141	1	15	6.9
NX210	56.5	40 / 63	11 x 25	149	1.3	157	1.6	30	16.7

\* Fr and Fa not cumulative: At 1500 min<sup>-1</sup> for a bearing service life of 20000 hours

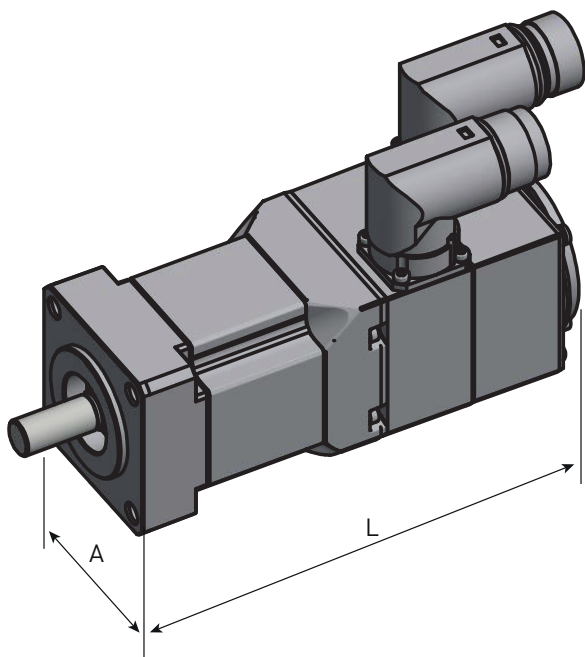

## Order Code

### NX1, NX2, UL - Natural Cooling Version

	1	2	3	4	5	6	7	8
Order example	<b>NX110A</b>	<b>A</b>	<b>J</b>	<b>R</b>	<b>7</b>	<b>0</b>	<b>0</b>	<b>0</b>

<b>1 Motor type</b>	<b>NX110A</b>	see table NX1-NX2 UL Motors
	<b>NX205A</b>	"Technical data"
	<b>NX210A</b>	
<b>2 Feedback sensor *</b>	<b>A</b>	2 pole resolver (standard)
	<b>Y</b>	Without sensor
	<b>R</b>	Absolute single-turn HIPERFACE encoder 128 ppt SKS36 (NX2 only)
	<b>S</b>	Absolute multi-turn HIPERFACE encoder 128 ppt SKM36 (NX2 only)
	<b>X</b>	Commutated lines 10 poles – 2048pulses (NX2 only)
<b>3 Motor type</b>	<b>J</b>	see table NX1-NX2 UL Motors
	<b>V</b>	"Technical data"
	<b>T</b>	
<b>4 Painting</b>	<b>R</b>	Unpainted (standard)
	<b>B</b>	Black mat (on request)
<b>5 Connector</b>	<b>7</b>	Standard
<b>6 Brake</b>	<b>0</b>	Without brake
	<b>3</b>	With brake
<b>7 Protection degree</b>	<b>0</b>	IP64 (standard)
	<b>1</b>	IP65
<b>8 Shaft end</b>	<b>0</b>	Smooth shaft (standard)
	<b>1</b>	Keyed shaft

\* other types of feedback sensor are available on request

# NX3-NX8 CE and UL Motors

## Technical Data

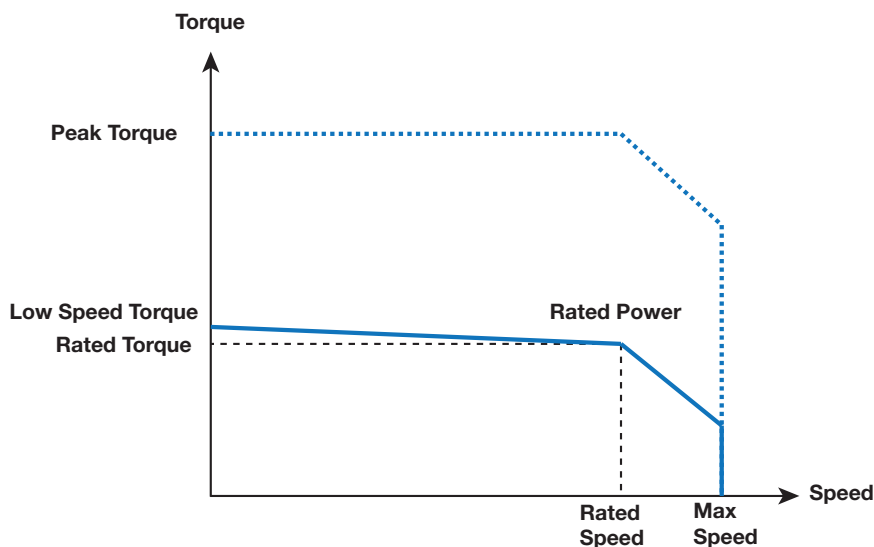

Model	Size	Stall <sup>(1)</sup>		Nominal <sup>(1)</sup>			Peak <sup>(1)</sup>	Inertia		Ke <sup>(2) (3)</sup>	Kt <sup>(2) (3)</sup>
		Torque	Current	Torque	Speed	Current	Torque	No brake	With brake		
		T <sub>0</sub> [Nm]	I <sub>0</sub> [A]	T <sub>n</sub> [Nm]	n [min <sup>-1</sup> ]	I <sub>n</sub> [A]	T <sub>max</sub> [Nm]	J [kgmm <sup>2</sup> ]	J [kgmm <sup>2</sup> ]	Ke [Vs]	Kt [Nm/A <sub>rms</sub> ]
<b>230VAC power supply - single or three-phased</b>											
NX310EAP	71	2	1.4	1.80	2300	1.27	6.6	80	87	88.9	1.440
NX310EAK	71	2	2.4	1.65	4000	2.06	6.6	80	87	50.9	0.823
NX420EAP	91.5	4	2.7	3.53	2300	2.41	13.4	290	308	89.9	1.480
NX420EAJ	91.5	4	4.7	3.14	4000	3.74	13.4	290	308	51.9	0.853
NX430EAL	91.5	5.5	3.8	5.04	2300	3.49	18.7	430	448	90.9	1.450
NX430EAF	91.5	5.5	6.6	4.29	4000	5.28	18.7	430	448	51.8	0.828
NX620EAV	121	8	2.8	7.85	1100	2.79	26.6	980	1 034	180.0	2.830
NX620EAR	121	8	5.3	7.42	2200	4.99	26.6	980	1 034	95.7	1.510
NX630EAR	121	12	5.3	10.70	1450	4.75	39.9	1 470	1 524	138.0	2.290
NX630EAN	121	12	7.9	9.81	2300	6.63	39.9	1 470	1 524	91.6	1.510
NX820EAR	155	16	11.0	14.50	2200	10.00	49.9	3 200	3 756	91.0	1.460
NX840EAK	155	28	16.8	23.50	2000	14.30	91.8	6 200	6 756	104.0	1.670
NX860EAJ	155	41	18.5	35.60	1450	16.20	136.0	9 200	9 756	140.0	2.210
<b>230 VAC power supply - three-phased - fan cooled</b>											
NX860VAF	155	64	42.7	56.40	2000	37.50	136.0	9 200	9 756	96.1	1.500
<b>230 VAC power supply - three-phased - water cooled</b>											
NX860WAF	155	90	62.6	88.30	2000	61.50	137.0	9 200	9 756	96.1	1.440

\* Mounting on aluminium flange: 400 x 400 x 12 mm (NX3-8) Temperature <40 °C near motor's flange

Model	Size	Stall <sup>(1)</sup>		Nominal <sup>(1)</sup>			Peak <sup>(1)</sup>	Inertia		Ke <sup>(2) (3)</sup>	Kt <sup>(2) (3)</sup>
		Torque	Current	Torque	Speed	Current	Torque	No brake	With brake		
		T <sub>0</sub> [Nm]	I <sub>0</sub> [A]	T <sub>n</sub> [Nm]	n [min <sup>-1</sup> ]	I <sub>n</sub> [A]	T <sub>max</sub> [Nm]	J [kgmm <sup>2</sup> ]	J [kgmm <sup>2</sup> ]	Ke [Vs]	Kt [Nm/A <sub>rms</sub> ]
<b>400 VAC power supply - single or three-phased</b>											
NX310EAP	71	2	1.4	1.65	4000	1.2	6.6	80	87	88.9	1.440
NX310EAK	71	2	2.4	1.36	7000	1.8	6.6	80	87	50.9	0.823
NX420EAP	91.5	4	2.7	3.14	4000	2.2	13.4	290	308	89.9	1.480
NX420EAJ	91.5	4	4.7	2.62	6000	3.2	13.4	290	308	51.9	0.853
NX430EAL	91.5	5.5	3.8	4.29	4000	3.0	18.7	430	448	90.9	1.450
NX430EAF	91.5	5.5	6.6	2.98	6000	3.8	18.7	430	448	51.8	0.828
NX620EAV	121	8	2.8	7.52	2000	2.7	26.6	980	1 034	180.0	2.830
NX620EAR	121	8	5.3	6.17	3900	4.3	26.6	980	1 034	95.7	1.510
NX630EAR	121	12	5.3	9.34	2700	4.2	39.9	1 470	1 524	138.0	2.290
NX630EAN	121	12	7.9	7.6	4000	5.3	39.9	1 470	1 524	91.6	1.510
NX820EAR	155	16	11.0	12.9	3900	9.1	49.9	3 200	3 756	91.0	1.460
NX840EAK	155	28	16.8	18.6	3500	11.5	91.8	6 200	6 756	104.0	1.670
NX860EAJ	155	41	18.5	27.5	2600	12.7	136.0	9 200	9 756	140.0	2.210
<b>400 VAC power supply - three-phased - fan cooled</b>											
NX860VAF	155	64	42.7	43.4	3750	28.9	136.0	9 200	9 756	96.1	1.500
<b>400 VAC power supply - three-phased - water cooled</b>											
NX860WAF	155	90	62.6	85.1	3750	59.3	137	9 200	9 756	96.1	1.440

<sup>(1)</sup> Data referred to motor mounted on aluminium flange: 400 x 400 x 12 mm (NX3-8) Temperature <40 °C near motor's flange. Stall torques refer to motor turning at 100 min<sup>-1</sup>

<sup>(2)</sup> Data measured at 20 °C. When "hot" consider -0.09 %/K derating

<sup>(3)</sup> Manufacturing tolerance data ±10 %

Low Cogging Servo Motor - NX Series  
 NX3-NX8 CE and UL Motors

Motor	Associated Drive Sizes					AC30
	PSD1S <sup>(2)</sup>	PSD1M	Compax3	SLVD-N	AC890	
<b>230VAC power supply - single or three-phased</b>						
NX310EAP	PSD1SW1200...	PSD1MW3222...	C3S025V2...	SLVD2N...	890SD-231300B...	-
NX310EAK	PSD1SW1300...	PSD1MW3433...	C3S025V2...	SLVD5N...	890SD-231550B...	-
NX420EAP	PSD1SW1300...	PSD1MW3433...	C3S063V2...	SLVD5N...	890SD-231700B...	-
NX420EAJ	PSD1SW1300...	PSD1MW3433...	C3S063V2...	SLVD5N...	890SD-231700B...	-
NX430EAL	PSD1SW1300...	PSD1MW3433...	C3S063V2...	SLVD5N...	890SD-231700B...	-
NX430EAF	-	PSD1MW2440...	C3S100V2...	SLVD7N...	890SD-232165B...	-
NX620EAV	PSD1SW1300...	PSD1MW3433...	C3S063V2...	SLVD5N...	890SD-231550B...	-
NX620EAR	-	PSD1MW2440...	C3S063V2...	SLVD7N...	890SD-231700B...	-
NX630EAR	-	PSD1MW2440...	C3S063V2...	SLVD7N...	890SD-232165B...	-
NX630EAN	-	PSD1MW2440...	C3S100V2...	SLVD10N...	890SD-232165B...	-
NX820EAR	-	PSD1MW2630...	C3S150V2...	SLVD15N...	890SD-232240C...	-
NX840EAK	-	-	-	-	890SD-232240C...	-
NX860EAJ	-	-	-	-	890SD-232240C...	-
<b>230 VAC power supply - three-phased - fan cooled</b>						
NX860VAF	-	-	-	-	-	-
<b>230 VAC power supply - three-phased - water cooled</b>						
NX860WAF	-	-	-	-	-	-

Motor	Associated Drive Sizes					AC30
	PSD1S <sup>(2)</sup>	PSD1M	Compax3	SLVD-N	AC890	
<b>400 VAC power supply - single or three-phased</b>						
NX310EAP	-	PSD1MW1300...	C3S015V4...	-	890SD-531200B...	31V-4D-0004
NX310EAK	-	PSD1MW1300...	C3S038V4...	-	890SD-531350B...	31V-4D-0004
NX420EAP	-	PSD1MW1300...	C3S038V4...	-	890SD-531450B...	31V-4D-0004
NX420EAJ	-	PSD1MW1300...	C3S075V4...	-	890SD-532100B...	31V-4D-0008
NX430EAL	-	PSD1MW1300...	C3S038V4...	-	890SD-532100B...	31V-4D-0005
NX430EAF	-	PSD1MW1400...	C3S075V4...	-	890SD-532120B...	31V-4D-0008
NX620EAV	-	PSD1MW1300...	C3S038V4...	-	890SD-531450B...	31V-4D-0004
NX620EAR	-	PSD1MW1400...	C3S075V4...	-	890SD-532100B...	31V-4D-0008
NX630EAR	-	PSD1MW1400...	C3S075V4...	-	890SD-532100B...	31V-4D-0008
NX630EAN	-	PSD1MW1600...	C3S150V4...	-	890SD-532120B...	31V-4D-0010
NX820EAR	-	PSD1MW1600...	C3S150V4...	-	890SD-532160B...	31V-4D-0012
NX840EAK	-	PSD1MW1800...	C3S300V4...	-	890SD-53216SB...	31V-4E-0023
NX860EAJ	-	PSD1MW1800...	C3S300V4...	-	890SD-532240C...	31V-4E-0023
<b>400 VAC power supply - three-phased - fan cooled</b>						
NX860VAJ	-	-	-	-	-	-
<b>400 VAC power supply - three-phased - water cooled</b>						
NX860WAF	-	-	C3H090V4...	-	890SD-432730E...	31V-4G0073...

## Dimensions

Motor	A	Mounting Flange centering / interaxis hole	Shaft diameter x length	Without Brake		With Brake		Fr* [daN]	Fa* [daN]
	[mm]			[mm]	L [mm]	Weight [kg]	L [mm]		
NX310	71	60 / 75-80	11 x 23	147	2	195	2.4	36	20
NX420	91.5	80 / 100	19 x 40	175	3.7	226	4.5	72	24
NX430	91.5	80 / 100	19 x 40	200	4.6	251	5.4	82	24
NX620	121	110 / 130	24 x 50	181	6.9	236	8	82	52
NX630	121	110 / 130	24 x 50	210	8.8	265	10	86	54

\* Fr and Fa not cumulative: At 1500 min<sup>-1</sup> for a bearing service life of 20000 hours

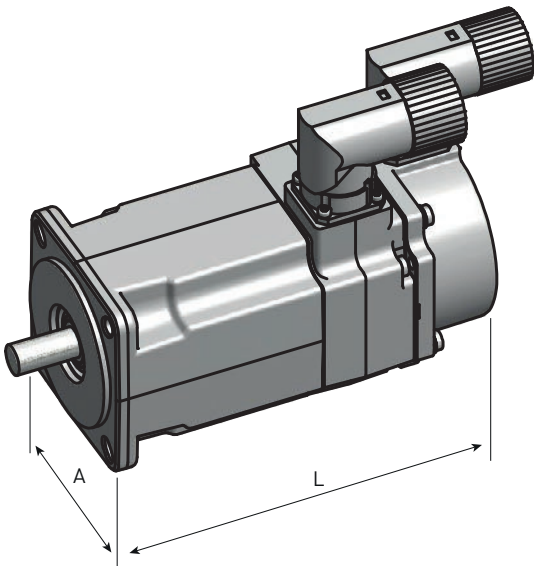

Motor	A	Mounting Flange centering / interaxis hole	Shaft diameter x length	Without Brake		With Brake		Fr* [daN]	Fa* [daN]
	[mm]			[mm]	L [mm]	Weight [kg]	L [mm]		
NX820	155	130 / 165	32 x 58	200	13	266	16.5	151	28
NX840	155	130 / 165	32 x 58	260	20	326	23.5	165	33
NX860	155	130 / 165	32 x 58	320	27	386	30.5	172	37

\* Fr and Fa not cumulative: At 1500 min<sup>-1</sup> for a bearing service life of 20000 hours

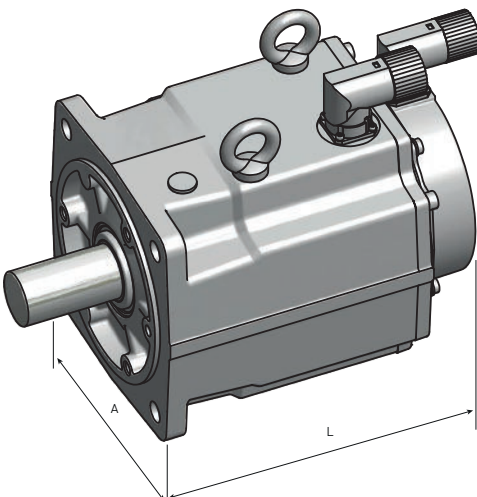

Low Cogging Servo Motor - NX Series  
 NX3-NX8 CE and UL Motors

Motor	A	Mounting Flange centering / interaxis hole	Shaft diameter x length	Without Brake		With Brake		Fr* [daN]	Fa* [daN]
	[mm]			[mm]	L [mm]	Weight [kg]	L [mm]		
<b>NX860V</b>	185	130 / 165	32 x 58	424	30.5	490	34	172	37

\* Fr and Fa not cumulative: At 1500 min<sup>-1</sup> for a bearing service life of 20 000 hours

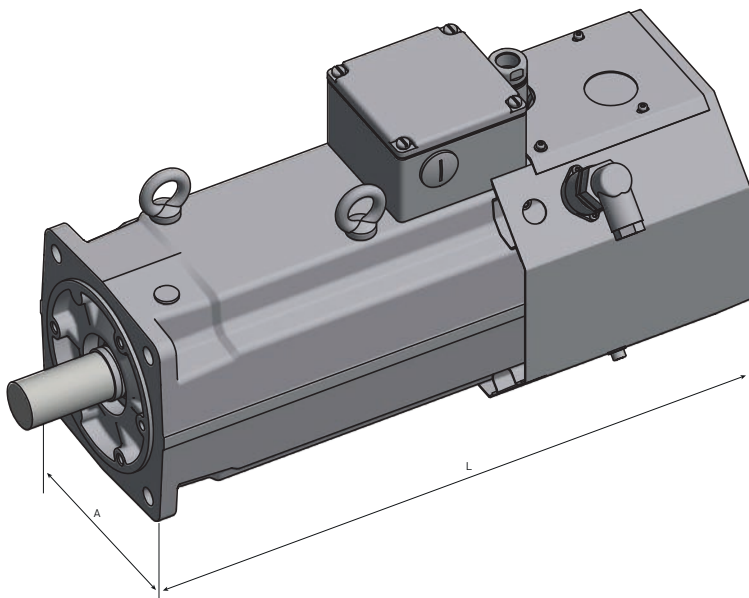

Motor	A	Mounting Flange centering / interaxis hole	Shaft diameter x length	Without Brake		With Brake		Fr* [daN]	Fa* [daN]
	[mm]			[mm]	L [mm]	Weight [kg]	L [mm]		
<b>NX860W</b>	155	130 / 165	32 x 58	360	28	426	31	172	37

\* Fr and Fa not cumulative: At 1500 min<sup>-1</sup> for a bearing service life of 20 000 hours

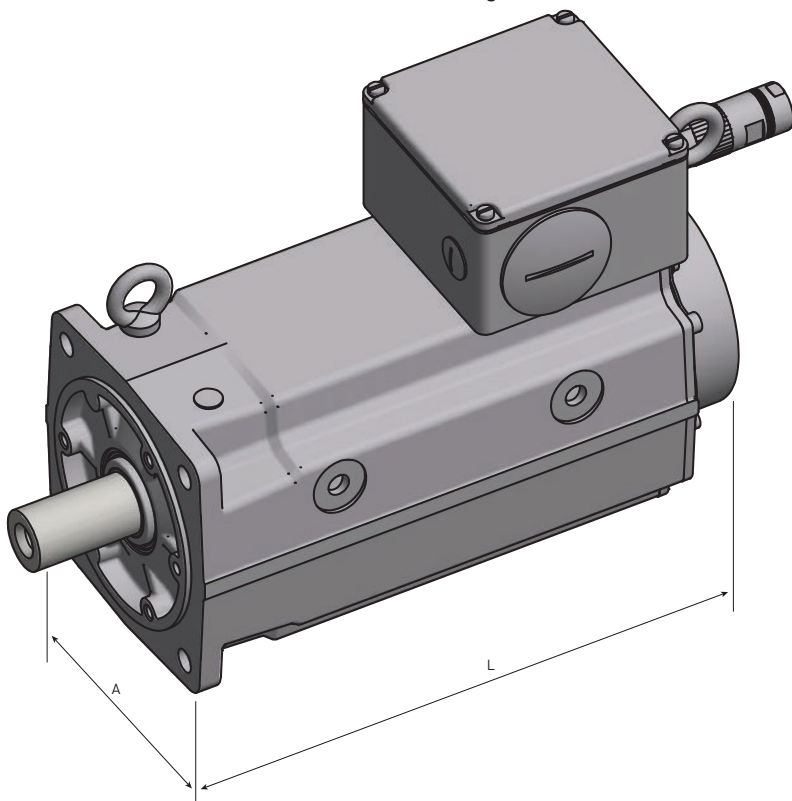



## Order Code

### NX3-NX8, CE, UL - Natural Cooling Version

	1	2	3	4	5	6	7	8
Order example	<b>NX310E</b>	<b>A</b>	<b>P</b>	<b>R</b>	<b>7</b>	<b>0</b>	<b>0</b>	<b>0</b>

#### 1 Motor type

<b>NX310E</b>	see table NX3-NX8 CE and UL Motors
<b>NX420E</b>	"Technical data"
<b>NX430E</b>	

...

#### 2 Feedback sensor \*

<b>A</b>	2 pole resolver (standard)
<b>K</b>	Without sensor
<b>P</b>	DSL HIPERFACE SIL2 single turn 128 ppr EKS36
<b>Q</b>	DSL HIPERFACE SIL2 multi turn 128 ppr EKM36
<b>R</b>	Absolute single-turn HIPERFACE encoder 128 ppr SKS36
<b>S</b>	Absolute multi-turn HIPERFACE encoder 128 ppr SKM36
<b>X</b>	Commutated lines 10 poles – 2048pulses

#### 3 Motor type

<b>P</b>	see table "Technical data"
<b>K</b>	
<b>X</b>	

...

#### 4 Painting

<b>R</b>	Unpainted (standard)
<b>B</b>	Black mat (on request)

#### 5 Connections/Ventilation

<b>1</b>	Shielded cables/No
<b>7</b>	Connectors (standard)/No
<b>5</b>	UL power terminal box + feedback connector (NX860V only)
<b>9</b>	CE power terminal box + feedback connector (NX860V only)

\* other types of feedback sensor are available on request

#### 6 Brake/Thermal Protection

<b>0</b>	Without brake (standard)/ No protection
<b>1</b>	Without brake/PTC on power connection
<b>2</b>	Without brake/Thermo switch on power connection (on request)
<b>3</b>	With brake/No protection
<b>4</b>	With brake/PTC on power connection
<b>5</b>	With brake/Thermo switch on power connection (on request)
<b>A</b>	Without brake/PTC on sensor connection (not available for UL version)
<b>B</b>	Without brake/Thermo switch on sensor connection (on request) (not available for UL version)
<b>C</b>	Without brake/KTY on sensor connector (not available for UL version)
<b>D</b>	With brake/PTC on sensor connection (not available for UL version)
<b>E</b>	With brake/Thermo switch on sensor connection (on request) (not available for UL version)
<b>F</b>	With brake/KTY on sensor connection (not available for UL version)

#### 7 Protection degree

<b>0</b>	IP44 for NX860V IP64 NX3 - NX8 (standard)
<b>1</b>	IP65 (option for NX3 - NX8)

#### 8 Shaft end

<b>0</b>	Smooth shaft (standard)
<b>1</b>	Keyed shaft

## Accessories and Options

Parker NX motors are available with standard and custom options to adapt motor on your application. If the option for your application is not listed, please consult our technical department.

### Cables

#### Motor cable

Drive	Cable reference <sup>(1)</sup>		
	NX1	NX2 to NX8	
		Current ≤ 12 A	Current ≤ 24 A
<b>With or without brake</b>			
Compax3	CC3UP0F4R0xxx	CC3UP1F1R0xxx	CC3UP2F1R0xxx
SLVDN	CS5UP0F4R0xxx	CS5UP1F1R0xxx	CS5UP2F1R0xxx
AC890	CS4UP0F4R0xxx	CS4UP1F1R0xxx	CS4UP2F1R0xxx
<b>With or without brake &amp; thermal sensor</b>			
Compax3	-	CC3UQ1F1R0xxx	CC3UQ2F1R0xxx
SLVDN	-	CS5UQ1F1R0xxx	CS5UQ2F1R0xxx
AC890	-	CS4UQ1F1R0xxx	CS4UQ2F1R0xxx
<b>With or without brake &amp; Hiperface DSL encoder</b>			
PSD1	-	CP1UD1F1R0xxx	CP1UD2F1R0xxx

#### Feedback cable

Drive	Cable reference <sup>(1)</sup>		
	Resolver for NX1	Resolver for NX2 to NX8	Hiperface encode
Compax3	CC3UA1F4R0xxx	CC3UA1F1R0xxx	CC3UR1F1R0xxx
SLVDN	CS5UA1F4R0xxx	CS5UA1F1R0xxx	CS5UR1F1R0xxx
AC890	CS4UA1F4R0xxx	CS4UA1F1R0xxx	

(\*) The 3 last digits indicate cable length in meters ±5 %max  
For non-standard length cable with length different from: 1/2/3/4/5/10/15/20/25/30/40/50 m please contact us.  
Example CC3UP1F1R0015: power cable, length = 15 m.



## Holding Brake

All NX motors are available with option holding brake.

Motor	Voltage	Power	Torque @ 20°C	Added length (resolver)	Added weight	Added inertia
	[V]	[W]	[Nm]	[mm]	[kg]	[kgmm <sup>2</sup> ]
NX1	24	6	0.4	31	0.2	0.01
NX2		8	1	37	0.3	0.12
NX3		11	2	48	0.4	0.068
NX4		12	5.5	51	0.9	0.18
NX6		18	12	55	1.1 (NX620)- 1.2 (NX630)	0.54
NX8		26	36	66	3.5	5.56

## Feedback

Motors may be equipped with various feedback types in order to meet the different requirements for precision, signal that the application needs. The standard motor includes the resolver feedback. Hiperface Encoder, DSL Encoder, Incremental Encoder are available like the following tables.

### Resolver 2 poles

Code	A		
Motor Association	NX1	NX2 & NX3	NX4, NX6 & NX8
Parker part number	220005P1000	220005P1001	220005P1002
Electrical specification	Values @ 8 kHz		
Polarity	2 poles		
Input voltage	7 Vrms		
Input current	70mA maximum	86mA maximum	
Zero voltage	20mV maximum		
Encoder accuracy	± 10' maxi		
Ratio	0,5 ± 5 %		
Output impedance (primary in short circuit whatever the position of the rotor)	Typical 120 + 200j Ω		
Dielectric rigidity (50 – 60 Hz)	500 V – 1 min		
Insulation resistance	≥ 10MΩ	≥ 100MΩ	
Rotor inertia	~6 g.cm	~30 g.cm <sup>2</sup>	
Operating temperature range	-55 to +155 °C		

### Incremental Encoder

Code	X
Motor Association	NX1, NX2, NX3, NX4, NX6 & NX8
Model	F10 (Hengstler)
Type	Incremental encoder with 10 pole commutation signals
Parker part number	220167P0003
Line count	2048 pulses per revolution
Electrical interface	Line driver 26LS31
System accuracy	Incremental signals ± 2.5' commutation signals ± 6'
Perating speed	5 000 rpm
Power Supply	5VDC ± 10%
Current consumption (without load)	100mA
Max pulse frequency	300 kHz
Operating temperature range	0°C to +120 °C

### Hiperface encoder DSL SIL2

Code	P	Q
Motor Association	NX2, NX3, NX4, NX6 & NX8	
Model	EKS36 SIL2(Sick)	EKM36 SIL2(Sick)
Type	Absolute single turn encoder	Absolute multi turn encoder
Parker part number	220174P0011	220174P0012
Electrical interface	Hiperface DSL	
Position values per revolution	4 096	-
Revolutions	-	4 096
Integral non-linearity	± 80" (Error limits for evaluating sine/cosine period)	
Differential non-linearity	± 40" (Non-linearity within a sine/cosine period)	
Operating speed	12 000 rpm	9 000 rpm
Power Supply	7VDC to 12VDC	
Current consumption	150 mA max.	
Output frequency	0kHz – 75kHz	
Operating temperature range	-20°C to +115 °C	

### Hiperface encoder

Code	R	S
Motor Association	NX2, NX3, NX4, NX6 & NX8	
Model	SKS36 (Sick)	SKM36 (Sick)
Type	Absolute single turn encoder	Absolute multi turn encoder
Parker part number	220174P0003	220174P0004
Line count	128 sine/cosine periods per revolution	
Electrical interface	Hiperface	
Position values per revolution	4 096	
Revolutions	-	4 096
Error limits for the digital absolute value	± 320" (via RS485)	
Integral non-linearity	± 80" (Error limits for evaluating sine/cosine period)	
Differential non-linearity	± 40" (Non-linearity within a sine/cosine period)	
Operating speed	12 000 rpm	9 000 rpm
Power Supply	7VDC to 12VDC	
Current consumption (without load)	60mA	
Output frequency	0kHz – 65kHz	
Operating temperature range	-20°C to +110 °C	

## NX1

### Power connector



Pin	Description
A	Phase U
B	Phase V
C	Phase W
	Ground
1	Brake +
2	Brake -

if the option is required

Part number	
220132R6610	

### Resolver connector

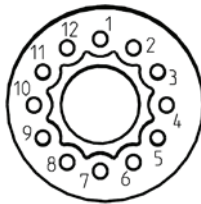

Pin	Description
1	S3 / Cos +
2	S1 / Cos -
7	S2 / Sin -
8	S4 / Sin +
10	R1 / excitation +
12	R2 / excitation -

Part number	
220132R6620	

## NX2 to NX8

### Power connector

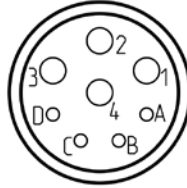

Pin	Description
1	Phase U
2	Ground
3	Phase W
4	Phase V
A	Brake +
B	Brake -
C	PTC or Thermoswitch or KTY Anode
D	PTC or Thermoswitch or KTY Cathode

if the option is required

### Power connector for feedback letter P/Q only

Pin	Description	
1	Phase U	
2	Ground	
3	Phase W	
4	Phase V	
A	-	Brake +
B	-	Brake -
C	DSL +	PTC or Thermoswitch or KTY Anode
D	DSL -	PTC or Thermoswitch or KTY Cathode

if the option is required

Part number	
220065R1610	

### Resolver connector feedback letter A



Pin	Description
1	S3 / Cos +
2	S1 / Cos -
3	PTC or Thermoswitch or KTY Anode
6	PTC or Thermoswitch or KTY Cathode
7	S2 / Sin -
8	S4 / Sin +
10	R1 / excitation +
12	R2 / excitation -

Part number	
220065R4621	

### Hiperface DSL® Connector feedback letter R/S/T/U

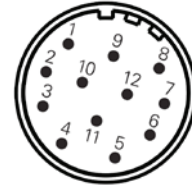

Pin	Description
1	Sin +
2	Ref Sin
3	Cos +
4	Ref Cos
5	PTC or Thermoswitch or KTY Anode
6	PTC or Thermoswitch or KTY Cathode
9	Data +
10	Data -
11	Us
12	Ground

if the option is required

Part number	
220065R4621	

### Incremental encoder connector feedback letter X



Pin	Description
1	Vcc
2	PTC or Thermoswitch or KTY Anode
3	Ground
4	U
5	V \
6	V
7	PTC or Thermoswitch or KTY Cathode
8	W
9	W \
10	A
11	A \
12	B
13	B \
14	Z
15	Z \
17	U \





# Parker's Motion & Control Technologies

At Parker, we're guided by a relentless drive to help our customers become more productive and achieve higher levels of profitability by engineering the best systems for their requirements. It means looking at customer applications from many angles to find new ways to create value. Whatever the motion and control technology need, Parker has the experience, breadth of product and global reach to consistently deliver. No company knows more about motion and control technology than Parker. For further info call 00800 27 27 5374



## Aerospace

### Key Markets

Aftermarket services  
Commercial transports  
Engines  
General & business aviation  
Helicopters  
Launch vehicles  
Military aircraft  
Missiles  
Power generation  
Regional transports  
Unmanned aerial vehicles

### Key Products

Control systems & actuation products  
Engine systems & components  
Fluid conveyance systems & components  
Fluid metering, delivery & atomization devices  
Fuel systems & components  
Fuel tank inerting systems  
Hydraulic systems & components  
Thermal management  
Wheels & brakes



## Climate Control

### Key Markets

Agriculture  
Air conditioning  
Construction Machinery  
Food & beverage  
Industrial machinery  
Life sciences  
Oil & gas  
Precision cooling  
Process  
Refrigeration  
Transportation

### Key Products

Accumulators  
Advanced actuators  
CO<sub>2</sub> controls  
Electronic controllers  
Filter driers  
Hand shut-off valves  
Heat exchangers  
Hose & fittings  
Pressure regulating valves  
Refrigerant distributors  
Safety relief valves  
Smart pumps  
Solenoid valves  
Thermostatic expansion valves



## Electromechanical

### Key Markets

Aerospace  
Factory automation  
Life science & medical  
Machine tools  
Packaging machinery  
Paper machinery  
Plastics machinery & converting  
Primary metals  
Semiconductor & electronics  
Textile  
Wire & cable

### Key Products

AC/DC drives & systems  
Electric actuators, gantry robots & slides  
Electrohydraulic actuation systems  
Electromechanical actuation systems  
Human machine interface  
Linear motors  
Stepper motors, servo motors, drives & controls  
Structural extrusions



## Filtration

### Key Markets

Aerospace  
Food & beverage  
Industrial plant & equipment  
Life sciences  
Marine  
Mobile equipment  
Oil & gas  
Power generation & renewable energy  
Process  
Transportation  
Water Purification

### Key Products

Analytical gas generators  
Compressed air filters & dryers  
Engine air, coolant, fuel & oil filtration systems  
Fluid condition monitoring systems  
Hydraulic & lubrication filters  
Hydrogen, nitrogen & zero air generators  
Instrumentation filters  
Membrane & fiber filters  
Microfiltration  
Sterile air filtration  
Water desalination & purification filters & systems



## Fluid & Gas Handling

### Key Markets

Aerial lift  
Agriculture  
Bulk chemical handling  
Construction machinery  
Food & beverage  
Fuel & gas delivery  
Industrial machinery  
Life sciences  
Marine  
Mining  
Mobile  
Oil & gas  
Renewable energy  
Transportation

### Key Products

Check valves  
Connectors for low pressure fluid conveyance  
Deep sea umbilicals  
Diagnostic equipment  
Hose couplings  
Industrial hose  
Mooring systems & power cables  
PTFE hose & tubing  
Quick couplings  
Rubber & thermoplastic hose  
Tube fittings & adapters  
Tubing & plastic fittings



## Hydraulics

### Key Markets

Aerial lift  
Agriculture  
Alternative energy  
Construction machinery  
Forestry  
Industrial machinery  
Machine tools  
Marine  
Material handling  
Mining  
Oil & gas  
Power generation  
Refuse vehicles  
Renewable energy  
Truck hydraulics  
Turf equipment

### Key Products

Accumulators  
Cartridge valves  
Electrohydraulic actuators  
Human machine interfaces  
Hybrid drives  
Hydraulic cylinders  
Hydraulic motors & pumps  
Hydraulic systems  
Hydraulic valves & controls  
Hydrostatic steering  
Integrated hydraulic circuits  
Power take-offs  
Power units  
Rotary actuators  
Sensors



## Pneumatics

### Key Markets

Aerospace  
Conveyor & material handling  
Factory automation  
Life science & medical  
Machine tools  
Packaging machinery  
Transportation & automotive

### Key Products

Air preparation  
Brass fittings & valves  
Manifolds  
Pneumatic accessories  
Pneumatic actuators & grippers  
Pneumatic valves & controls  
Quick disconnects  
Rotary actuators  
Rubber & thermoplastic hose & couplings  
Structural extrusions  
Thermoplastic tubing & fittings  
Vacuum generators, cups & sensors



## Process Control

### Key Markets

Alternative fuels  
Biopharmaceuticals  
Chemical & refining  
Food & beverage  
Marine & shipbuilding  
Medical & dental  
Microelectronics  
Nuclear Power  
Offshore oil exploration  
Oil & gas  
Pharmaceuticals  
Power generation  
Pulp & paper  
Steel  
Water/wastewater

### Key Products

Analytical Instruments  
Analytical sample conditioning products & systems  
Chemical injection fittings & valves  
Fluoropolymer chemical delivery fittings, valves & pumps  
High purity gas delivery fittings, valves, regulators & digital flow controllers  
Industrial mass flow meters/controllers  
Permanent no-weld tube fittings  
Precision industrial regulators & flow controllers  
Process control double block & bleeds  
Process control fittings, valves, regulators & manifold valves



## Sealing & Shielding

### Key Markets

Aerospace  
Chemical processing  
Consumer  
Fluid power  
General industrial  
Information technology  
Life sciences  
Microelectronics  
Military  
Oil & gas  
Power generation  
Renewable energy  
Telecommunications  
Transportation

### Key Products

Dynamic seals  
Elastomeric o-rings  
Electro-medical instrument design & assembly  
EMI shielding  
Extruded & precision-cut, fabricated elastomeric seals  
High temperature metal seals  
Homogeneous & inserted elastomeric shapes  
Medical device fabrication & assembly  
Metal & plastic retained composite seals  
Shielded optical windows  
Silicone tubing & extrusions  
Thermal management  
Vibration dampening

# Parker Worldwide

## Europe, Middle East, Africa

**AE – United Arab Emirates, Dubai**  
Tel: +971 4 8127100  
parker.me@parker.com

**AT – Austria, Wiener Neustadt**  
Tel: +43 (0)2622 23501-0  
parker.austria@parker.com

**AT – Eastern Europe, Wiener Neustadt**  
Tel: +43 (0)2622 23501 900  
parker.easteurope@parker.com

**AZ – Azerbaijan, Baku**  
Tel: +994 50 2233 458  
parker.azerbaijan@parker.com

**BE/LU – Belgium, Nivelles**  
Tel: +32 (0)67 280 900  
parker.belgium@parker.com

**BG – Bulgaria, Sofia**  
Tel: +359 2 980 1344  
parker.bulgaria@parker.com

**BY – Belarus, Minsk**  
Tel: +48 (0)22 573 24 00  
parker.poland@parker.com

**CH – Switzerland, Etoy**  
Tel: +41 (0)21 821 87 00  
parker.switzerland@parker.com

**CZ – Czech Republic, Klecany**  
Tel: +420 284 083 111  
parker.czechrepublic@parker.com

**DE – Germany, Kaarst**  
Tel: +49 (0)2131 4016 0  
parker.germany@parker.com

**DK – Denmark, Ballerup**  
Tel: +45 43 56 04 00  
parker.denmark@parker.com

**ES – Spain, Madrid**  
Tel: +34 902 330 001  
parker.spain@parker.com

**FI – Finland, Vantaa**  
Tel: +358 (0)20 753 2500  
parker.finland@parker.com

**FR – France, Contamine s/Arve**  
Tel: +33 (0)4 50 25 80 25  
parker.france@parker.com

**GR – Greece, Athens**  
Tel: +30 210 933 6450  
parker.greece@parker.com

**HU – Hungary, Budaörs**  
Tel: +36 23 885 470  
parker.hungary@parker.com

**IE – Ireland, Dublin**  
Tel: +353 (0)1 466 6370  
parker.ireland@parker.com

**IL – Israel**  
Tel: +39 02 45 19 21  
parker.israel@parker.com

**IT – Italy, Corsico (MI)**  
Tel: +39 02 45 19 21  
parker.italy@parker.com

**KZ – Kazakhstan, Almaty**  
Tel: +7 7273 561 000  
parker.easteurope@parker.com

**NL – The Netherlands, Oldenzaal**  
Tel: +31 (0)541 585 000  
parker.nl@parker.com

**NO – Norway, Asker**  
Tel: +47 66 75 34 00  
parker.norway@parker.com

**PL – Poland, Warsaw**  
Tel: +48 (0)22 573 24 00  
parker.poland@parker.com

**PT – Portugal**  
Tel: +351 22 999 7360  
parker.portugal@parker.com

**RO – Romania, Bucharest**  
Tel: +40 21 252 1382  
parker.romania@parker.com

**RU – Russia, Moscow**  
Tel: +7 495 645-2156  
parker.russia@parker.com

**SE – Sweden, Spånga**  
Tel: +46 (0)8 59 79 50 00  
parker.sweden@parker.com

**SK – Slovakia, Banská Bystrica**  
Tel: +421 484 162 252  
parker.slovakia@parker.com

**SL – Slovenia, Novo Mesto**  
Tel: +386 7 337 6650  
parker.slovenia@parker.com

**TR – Turkey, Istanbul**  
Tel: +90 216 4997081  
parker.turkey@parker.com

**UA – Ukraine, Kiev**  
Tel: +48 (0)22 573 24 00  
parker.poland@parker.com

**UK – United Kingdom, Warwick**  
Tel: +44 (0)1926 317 878  
parker.uk@parker.com

**ZA – South Africa, Kempton Park**  
Tel: +27 (0)11 961 0700  
parker.southafrica@parker.com

## North America

**CA – Canada, Milton, Ontario**  
Tel: +1 905 693 3000

**US – USA, Cleveland**  
Tel: +1 216 896 3000

## Asia Pacific

**AU – Australia, Castle Hill**  
Tel: +61 (0)2-9634 7777

**CN – China, Shanghai**  
Tel: +86 21 2899 5000

**HK – Hong Kong**  
Tel: +852 2428 8008

**IN – India, Mumbai**  
Tel: +91 22 6513 7081-85

**JP – Japan, Tokyo**  
Tel: +81 (0)3 6408 3901

**KR – South Korea, Seoul**  
Tel: +82 2 559 0400

**MY – Malaysia, Shah Alam**  
Tel: +60 3 7849 0800

**NZ – New Zealand, Mt Wellington**  
Tel: +64 9 574 1744

**SG – Singapore**  
Tel: +65 6887 6300

**TH – Thailand, Bangkok**  
Tel: +662 186 7000

**TW – Taiwan, Taipei**  
Tel: +886 2 2298 8987

## South America

**AR – Argentina, Buenos Aires**  
Tel: +54 3327 44 4129

**BR – Brazil, Sao Jose dos Campos**  
Tel: +55 800 727 5374

**CL – Chile, Santiago**  
Tel: +56 2 623 1216

**MX – Mexico, Toluca**  
Tel: +52 72 2275 4200



### EMEA Product Information Centre

Free phone: 00 800 27 27 5374

(from AT, BE, CH, CZ, DE, DK, EE, ES, FI, FR, IE, IL, IS, IT, LU, MT, NL, NO, PL, PT, RU, SE, SK, UK, ZA)

### US Product Information Centre

Toll-free number: 1-800-27 27 537

www.parker.com