

Servomotors

EX Series

Technical Manual

PVD 3665 - EX

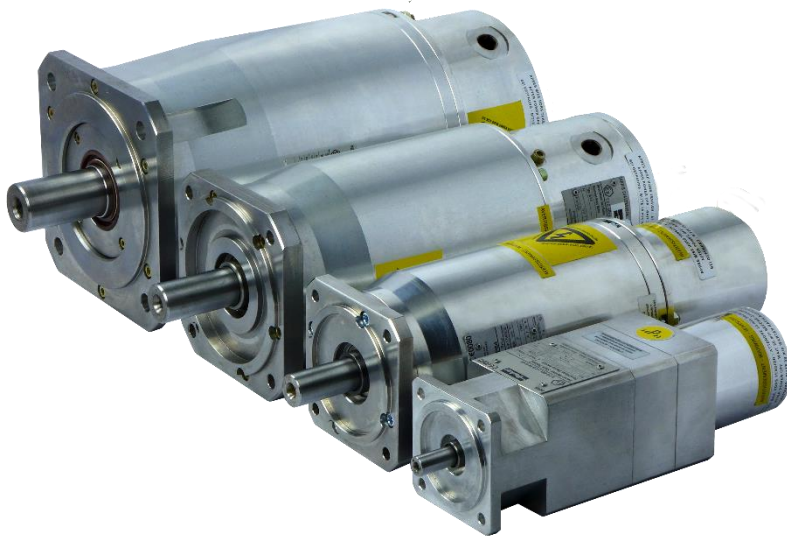
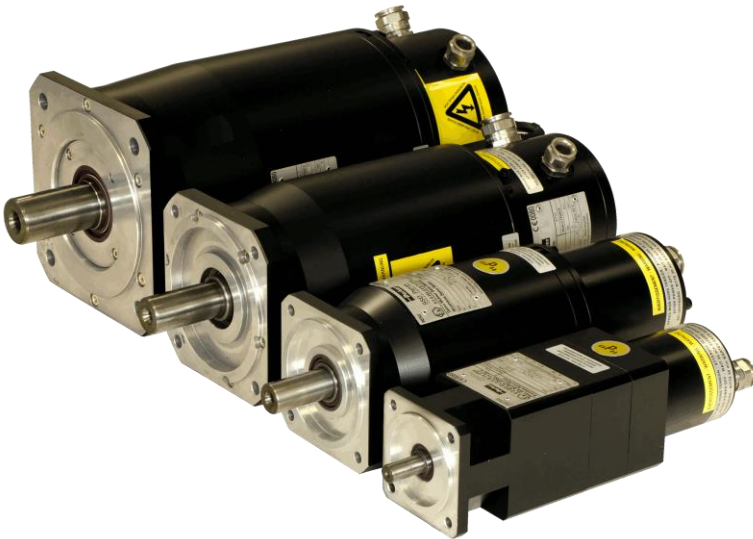



EU DECLARATION OF CONFORMITY

We,

Parker Hannifin Manufacturing France SAS
Electric Motion & Pneumatic Division
Etablissement de Longvic
4 Boulevard Eiffel - CS40090
21604 LONGVIC Cedex - France

manufacturer, with brand name **Parker**, declare under our sole responsibility that the products,

SERVOMOTORS TYPE EX3 - EX4 - EX6 - EX8 with the following marking :

 II 2 G / Ex db IIB T4 Gb IP64
or
 II 2 GD / Ex db IIB T4 Gb IP65 / Ex tb IIIC T135°C Db IP65

satisfy the arrangements of the directives :

Directive 2014/35/EU : “Low Voltage Directive”, LVD
Directive 2011/65/EU + delegated Directive (EU) 2015/863 : RoHS 3 “Restriction of Hazardous Substances”
Directive 2014/34/EU : “Equipment and protective systems intended for use in potentially explosive atmospheres”

and meet standards or normative document according to :

IEC 60034-1:2017 : Rotating electrical machines - Part 1 : Rating and performance.
IEC 60034-5:2020 : Rotating electrical machines - Part 5 : Degrees of protection provided by the integral design of rotating electrical machines (IP code) - Classification.
IEC 60079-0:2011 / EN 60079-0:2012/A11:2013 : Explosive atmospheres - Part 0 : Equipment - General requirements.
IEC 60079-1:2014 / EN 60079-1:2014 : Explosive atmospheres - Part 1 : Equipment protection by flameproof enclosures “d”.
IEC 60079-31:2013 / EN 60079-31:2014 : Explosive atmospheres - Part 31 : Equipment dust ignition protection by enclosure “t”.

The product is not impacted by the modifications made on the latest harmonized standards, therefore it stays conform to the essential requirements regarding the healthy and the safety to the directive 2014/34/EU.

EX3 EC-Type Examination certificate : INERIS 03ATEX0060X + additions 1 to 4.
EX4 EC-Type Examination certificate : INERIS 04ATEX0097X + additions 1 to 6.
EX6 EC-Type Examination certificate : INERIS 04ATEX0032X + additions 1 to 5.
EX8 EC-Type Examination certificate : INERIS 05ATEX0061X + additions 1 to 5.
Quality system notification : **INERIS** body EC 0080.

The undersigned certify that the above mentioned model is procured in accordance with the above directives and standards.



The servomotors type EX3 - EX4 - EX6 - EX8 are also certified IECEx.
IECEx Certification : INE 15.0060X

Further information :

For an ambient temperature of -20°C to +40°C the servomotors shall be mounted on a mechanical support providing good heat conduction and not exceeding 40° C in the vicinity of the motor flange.
For an ambient temperature of -20°C to +60°C the servomotors shall be mounted on a mechanical support providing good heat conduction and not exceeding 60° C in the vicinity of the motor flange.

The product must be installed in accordance with the instructions and recommendations contained in the operating instructions PVD3665 supplied with the product.

1st Motor CE marking :

EX3 CE Marking in : June 04th 2003
EX4 CE Marking in : January 24th 2005

EX6 CE Marking in : March 09th 2004
EX8 CE Marking in : May 30th 2005

Longvic, August 25th 2022

Ref : DCE-EX-003rev7

In the name of Parker
R. WENDLING
Business Unit Manager

Raphael Wendling
Digital unterschrieben von Raphael
Wendling
Datum: 2022.08.30 22:26:42 +02'00'



CERTIFICATE FOR CHINA COMPULSORY PRODUCT CERTIFICATION

No.: 2021312301002772

Applicant PARKER HANNIFIN MANUFACTURING France SAS
Address 4 boulevard Eiffel, 21604 LONGVIC, France
Manufacturer PARKER HANNIFIN MANUFACTURING France SAS
Address 4 boulevard Eiffel, 21604 LONGVIC, France
Production Factory PARKER HANNIFIN MANUFACTURING France SAS
Production Address 4 boulevard Eiffel, 21604 LONGVIC, France
Product Servomotor
Model/Type EX310E***1**C
Ex marking Ex d IIB T4 Gb, Ex tD A21 IP65 T135°C
Reference Standards GB3836.1-2010, GB3836.2-2010, GB12476.1-2013, GB12476.5-2013

Certification mode Type Test + Initial Factory Inspection + Post-Certification Surveillance

The product(s) is verified and certified according to CNCA-C23-01: 2019 *China Compulsory Certification Implementation Rule on Explosion Protected Electrical Product* and CNEX-C2301-2019 *Guideline of China Compulsory Certification Implementation Rule on Explosion Protected Electrical Product*.

See Annex for the detailed product information (4 pages)

Issued on: 2021-02-01

Valid to: 2026-01-31

The validity of this certificate is maintained through the regular supervision of the issuing authority during the validity period.

Where any discrepancy arises between the English translation and the original Chinese version, the Chinese version shall prevail.

Director:



Nanyang Explosion Protected Electrical Apparatus Research Institute Co.,Ltd.



<http://www.ccc-cnex.com>
ccc.china-ex.com

Add: No. 20, North Zhongjing Road, Nanyang, Henan, P. R. China
Tel: 0377-63239734

P.C.: 473008
Email: ccc@cn-ex.com

CN 0000491



中国国家强制性产品认证证书

编号: 2021312301002772

委托人	PARKER HANNIFIN MANUFACTURING France SAS
地址	4 boulevard Eiffel, 21604 LONGVIC, France
生产者	PARKER HANNIFIN MANUFACTURING France SAS
地址	4 boulevard Eiffel, 21604 LONGVIC, France
生产企业	PARKER HANNIFIN MANUFACTURING France SAS
生产地址	4 boulevard Eiffel, 21604 LONGVIC, France
产品名称	伺服电机
型号规格	EX310E***1**C
防爆标志	Ex d IIB T4 Gb, Ex tD A21 IP65 T135°C
依据标准	GB3836.1-2010, GB3836.2-2010, GB12476.1-2013, GB12476.5-2013

认证模式 型式试验+初始工厂检查+获证后监督

上述产品符合 CNCA-C23-01: 2019 《强制性产品认证实施规则 防爆电气》
和 CNEX-C2301-2019 《强制性产品认证实施细则 防爆电气》的要求。

产品相关信息见附页 (共 4 页)。

颁发日期 2021 年 02 月 01 日

有效期至 2026 年 01 月 31 日

证书有效期内本证书的有效性依据发证机构的定期监督获得保持。

主任:



南阳防爆电气研究所有限公司



网址: www.ccc-cnex.com
ccc.china-ex.com

地址: 中国河南省南阳市仲景北路20号
电话: 0377-63239734

邮政编码: 473008
邮箱: ccc@cn-ex.com

CN 0010466



CERTIFICATE FOR CHINA COMPULSORY PRODUCT CERTIFICATION

No.: 2021312301002773

Applicant	PARKER HANNIFIN MANUFACTURING France SAS
Address	4 boulevard Eiffel, 21604 LONGVIC, France
Manufacturer	PARKER HANNIFIN MANUFACTURING France SAS
Address	4 boulevard Eiffel, 21604 LONGVIC, France
Production Factory	PARKER HANNIFIN MANUFACTURING France SAS
Production Address	4 boulevard Eiffel, 21604 LONGVIC, France
Product	Servomotor
Model/Type	EX4*E***1**C
Ex marking	Ex d IIB T4 Gb, Ex tD A21 IP65 T135°C
Reference Standards	GB3836.1-2010, GB3836.2-2010, GB12476.1-2013, GB12476.5-2013

Certification mode Type Test + Initial Factory Inspection + Post-Certification Surveillance

The product(s) is verified and certified according to CNCA-C23-01: 2019 *China Compulsory Certification Implementation Rule on Explosion Protected Electrical Product* and CNEX-C2301-2019 *Guideline of China Compulsory Certification Implementation Rule on Explosion Protected Electrical Product*.

See Annex for the detailed product information (4 pages)

Issued on: 2021-02-01

Valid to: 2026-01-31

The validity of this certificate is maintained through the regular supervision of the issuing authority during the validity period.

Where any discrepancy arises between the English translation and the original Chinese version, the Chinese version shall prevail.

Director:



Nanyang Explosion Protected Electrical Apparatus Research Institute Co.,Ltd.



<http://www.ccc-cnex.com>
ccc.china-ex.com

Add: No. 20, North Zhongjing Road, Nanyang, Henan, P. R. China
Tel: 0377-63239734

P.C.: 473008
Email: ccc@cn-ex.com

CN 0000492



中国国家强制性产品认证证书

编号: 2021312301002773

委托人 PARKER HANNIFIN MANUFACTURING France SAS
地址 4 boulevard Eiffel, 21604 LONGVIC, France
生产者 PARKER HANNIFIN MANUFACTURING France SAS
地址 4 boulevard Eiffel, 21604 LONGVIC, France
生产企业 PARKER HANNIFIN MANUFACTURING France SAS
生产地址 4 boulevard Eiffel, 21604 LONGVIC, France
产品名称 伺服电机
型号规格 EX4*E***1**C
防爆标志 Ex d IIB T4 Gb, Ex tD A21 IP65 T135°C
依据标准 GB3836.1-2010, GB3836.2-2010, GB12476.1-2013,
GB12476.5-2013

认证模式 型式试验+初始工厂检查+获证后监督

上述产品符合 CNCA-C23-01: 2019 《强制性产品认证实施规则 防爆电气》
和 CNEX-C2301-2019 《强制性产品认证实施细则 防爆电气》的要求。

产品相关信息见附页 (共 4 页)。

颁发日期 2021 年 02 月 01 日

有效期至 2026 年 01 月 31 日

证书有效期内本证书的有效性依据发证机构的定期监督获得保持。

主任:



南阳防爆电气研究所有限公司



网址: www.ccc-cnex.com
ccc.china-ex.com

地址: 中国河南省南阳市仲景北路20号
电话: 0377-63239734

邮政编码: 473008
邮箱: ccc@cn-ex.com

CN 0010467



CERTIFICATE FOR CHINA COMPULSORY PRODUCT CERTIFICATION

No.: 2021312301002774

Applicant PARKER HANNIFIN MANUFACTURING France SAS
Address 4 boulevard Eiffel, 21604 LONGVIC, France
Manufacturer PARKER HANNIFIN MANUFACTURING France SAS
Address 4 boulevard Eiffel, 21604 LONGVIC, France
Production Factory PARKER HANNIFIN MANUFACTURING France SAS
Production Address 4 boulevard Eiffel, 21604 LONGVIC, France
Product Servomotor
Model/Type EX6*E***1**C
Ex marking Ex d IIB T4 Gb, Ex tD A21 IP65 T135°C
Reference Standards GB3836.1-2010, GB3836.2-2010, GB12476.1-2013, GB12476.5-2013

Certification mode Type Test + Initial Factory Inspection + Post-Certification Surveillance

The product(s) is verified and certified according to CNCA-C23-01: 2019 *China Compulsory Certification Implementation Rule on Explosion Protected Electrical Product* and CNEX-C2301-2019 *Guideline of China Compulsory Certification Implementation Rule on Explosion Protected Electrical Product*.

See Annex for the detailed product information (4 pages)

Issued on: 2021-02-01

Valid to: 2026-01-31

The validity of this certificate is maintained through the regular supervision of the issuing authority during the validity period.

Where any discrepancy arises between the English translation and the original Chinese version, the Chinese version shall prevail.

Director:



Nanyang Explosion Protected Electrical Apparatus Research Institute Co.,Ltd.



<http://www.ccc-cnex.com>
ccc.china-ex.com

Add: No. 20, North Zhongjing Road, Nanyang, Henan, P. R. China
Tel: 0377-63239734

P.C.: 473008
Email: ccc@cn-ex.com

CN 0000493



中国国家强制性产品认证证书

编号: 2021312301002774

委托人	PARKER HANNIFIN MANUFACTURING France SAS
地址	4 boulevard Eiffel, 21604 LONGVIC, France
生产者	PARKER HANNIFIN MANUFACTURING France SAS
地址	4 boulevard Eiffel, 21604 LONGVIC, France
生产企业	PARKER HANNIFIN MANUFACTURING France SAS
生产地址	4 boulevard Eiffel, 21604 LONGVIC, France
产品名称	伺服电机
型号规格	EX6*E***1**C
防爆标志	Ex d IIB T4 Gb, Ex tD A21 IP65 T135°C
依据标准	GB3836.1-2010, GB3836.2-2010, GB12476.1-2013, GB12476.5-2013

认证模式 型式试验+初始工厂检查+获证后监督

上述产品符合 CNCA-C23-01: 2019 《强制性产品认证实施规则 防爆电气》
和 CNEX-C2301-2019 《强制性产品认证实施细则 防爆电气》的要求。

产品相关信息见附页 (共 4 页)。

颁发日期 2021 年 02 月 01 日

有效期至 2026 年 01 月 31 日

证书有效期内本证书的有效性依据发证机构的定期监督获得保持。

主任:



南阳防爆电气研究所有限公司



网址: www.ccc-cnex.com
ccc.china-ex.com

地址: 中国河南省南阳市仲景北路20号
电话: 0377-63239734

邮政编码: 473008
邮箱: ccc@cn-ex.com

CN 0010468



CERTIFICATE FOR CHINA COMPULSORY PRODUCT CERTIFICATION

No.: 2021312301002775

Applicant	PARKER HANNIFIN MANUFACTURING France SAS
Address	4 boulevard Eiffel, 21604 LONGVIC, France
Manufacturer	PARKER HANNIFIN MANUFACTURING France SAS
Address	4 boulevard Eiffel, 21604 LONGVIC, France
Production Factory	PARKER HANNIFIN MANUFACTURING France SAS
Production Address	4 boulevard Eiffel, 21604 LONGVIC, France
Product	Servomotor
Model/Type	EX8*E***1**C
Ex marking	Ex d IIB T4 Gb, Ex tD A21 IP65 T135°C
Reference Standards	GB3836.1-2010, GB3836.2-2010, GB12476.1-2013, GB12476.5-2013

Certification mode Type Test + Initial Factory Inspection + Post-Certification Surveillance

The product(s) is verified and certified according to CNCA-C23-01: 2019 *China Compulsory Certification Implementation Rule on Explosion Protected Electrical Product* and CNEX-C2301-2019 *Guideline of China Compulsory Certification Implementation Rule on Explosion Protected Electrical Product*.

See Annex for the detailed product information (4pages)

Issued on: 2021-02-01

Valid to: 2026-01-31

The validity of this certificate is maintained through the regular supervision of the issuing authority during the validity period.

Where any discrepancy arises between the English translation and the original Chinese version, the Chinese version shall prevail.

Director:



Nanyang Explosion Protected Electrical Apparatus Research Institute Co.,Ltd.



<http://www.ccc-cnex.com>
ccc.china-ex.com

Add: No. 20, North Zhongjing Road, Nanyang, Henan, P. R. China
Tel: 0377-63239734

P.C.: 473008
Email: ccc@cn-ex.com

CN 0000494



中国国家强制性产品认证证书

编号: 2021312301002775

委 托 人	PARKER HANNIFIN MANUFACTURING France SAS
地 址	4 boulevard Eiffel, 21604 LONGVIC, France
生 产 者	PARKER HANNIFIN MANUFACTURING France SAS
地 址	4 boulevard Eiffel, 21604 LONGVIC, France
生 产 企 业	PARKER HANNIFIN MANUFACTURING France SAS
生 产 地 址	4 boulevard Eiffel, 21604 LONGVIC, France
产 品 名 称	伺服电机
型 号 规 格	EX8*E***1**C
防 爆 标 志	Ex d IIB T4 Gb, Ex tD A21 IP65 T135°C
依 据 标 准	GB3836.1-2010, GB3836.2-2010, GB12476.1-2013, GB12476.5-2013

认 证 模 式 型式试验+初始工厂检查+获证后监督

上述产品符合 CNCA-C23-01: 2019《强制性产品认证实施规则 防爆电气》
和 CNEX-C2301-2019《强制性产品认证实施细则 防爆电气》的要求。

产品相关信息见附页 (共 4 页)。

颁发日期 2021 年 02 月 01 日

有效期至 2026 年 01 月 31 日

证书有效期内本证书的有效性依据发证机构的定期监督获得保持。

主任:



南阳防爆电气研究所有限公司



网址: www.ccc-cnex.com
ccc.china-ex.com

地址: 中国河南省南阳市仲景北路20号
电话: 0377-63239734

中国认可
产品
PRODUCT
CNAS C208-P
邮政编码: 473008
邮箱: ccc@cn-ex.com

CN 0010469



안 전 인 증 서

Parker Hannifin Manufacturing France SAS

4 Boulevard Eiffel 21604 LONGVIC France

위 사업장에서 제조하는 아래의 품목이 산업안전보건법 제34조 및 같은 법 시행규칙 제58조의4제4항에 따른 안전인증 심사 결과 안전·보건 기준에 적합하므로 안전인증표시의 사용을 인증합니다.

품 목

방폭구조 전기기계·기구(AC Brushless Servo Motor)

형식·모델/용량·등급/인증번호

형식·모델	인증번호
EX310Eabc12de	16-AV4BO-0493X
용량·등급	
Ex d IIB T4	
a(Feedback): A/E/G/R/S/X/Y, b(Winding),	
c(Painting): R(Non)/B(Black), d(IP): 0(IP64)/1(IP65),	
e(shaft):0/1, 브레이크없음, 정격: (뒤쪽)참조	

인 증 기 준

방호장치 의무안전인증 고시(고용노동부고시 제2013-54호)

인 증 조 건

(뒤쪽)참조

2016년 12월 21일

한국산업안전보건공단 이사장



제 2016-BO-0494 호



(앞쪽)

안 전 인 증 서

Parker Hannifin Manufacturing France SAS

4 Boulevard Eiffel 21604 LONGVIC France

위 사업장에서 제조하는 아래의 품목이 산업안전보건법 제34조 및 같은 법 시행규칙 제58조의4제4항에 따른 안전인증 심사 결과 안전·보건 기준에 적합하므로 안전인증표시의 사용을 인증합니다.

품 목

방폭구조 전기기계·기구(AC Brushless Servo Motor)

형식·모델/용량·등급/인증번호

형식·모델	인증번호
EX310Eabc15de	16-AV4BO-0494X
용량·등급	Ex d IIB T4 a(Feedback): A/E/G/R/S/X/Y, b(Winding), c(Painting): R(Non)/B(Black), d(IP): 0(IP64)/1(IP65), e(shaft):0/1, 브레이크있음, 정격: (뒤쪽)참조

인 증 기 준

방호장치 의무안전인증 고시(고용노동부고시 제2013-54호)

인 증 조 건

(뒤쪽)참조

2016년 12월 21일

한국산업안전보건공단 이사장



제 2016-BO-0496 호



(앞쪽)

안 전 인 증 서

Parker Hannifin Manufacturing France SAS

4 Boulevard Eiffel 21604 LONGVIC France

위 사업장에서 제조하는 아래의 품목이 산업안전보건법 제34조 및 같은 법 시행규칙 제58조의4제4항에 따른 안전인증 심사 결과 안전·보건 기준에 적합하므로 안전인증표시의 사용을 인증합니다.

품 목

방폭구조 전기기계·기구(AC Brushless Servo Motor)

형식·모델/용량·등급/인증번호

형식·모델	인증번호
EX4a0Ebcd15ef	16-AV4BO-0496X
용량·등급	Ex d IIB T4
	a(length): 2/3, b(Feedback): A/G/R/S/T/U/X/Y, c(Winding),
	d(Painting): R(Non)/B(Black), e(IP): 0(IP64)/1(IP65),
	f(shaft):0/1, 브레이크있음, 정격: (뒤쪽)참조

인 증 기 준

방호장치 의무안전인증 고시(고용노동부고시 제2013-54호)

인 증 조 건

(뒤쪽)참조

2016년 12월 21일

한국산업안전보건공단 이사장



제 2016-BO-0495 호



(앞쪽)

안 전 인 증 서

Parker Hannifin Manufacturing France SAS

4 Boulevard Eiffel 21604 LONGVIC France

위 사업장에서 제조하는 아래의 품목이 산업안전보건법 제34조 및 같은 법 시행규칙 제58조의4제4항에 따른 안전인증 심사 결과 안전·보건 기준에 적합하므로 안전인증표시의 사용을 인증합니다.

품 목

방폭구조 전기기계·기구(AC Brushless Servo Motor)

형식·모델/용량·등급/인증번호

형식·모델	인증번호
EX4a0Ebcd12ef	16-AV4BO-0495X
용량·등급	Ex d IIB T4
	a(length): 2/3, b(Feedback): A/G/R/S/T/U/X/Y, c(Winding), d(Painting): R(Non)/B(Black), e(IP): 0(IP64)/1(IP65), f(shaft):0/1, 브레이크없음, 정격: (뒤쪽)참조

인 증 기 준

방호장치 의무안전인증 고시(고용노동부고시 제2013-54호)

인 증 조 건

(뒤쪽)참조

2016년 12월 21일

한국산업안전보건공단 이사장





안 전 인 증 서

Parker Hannifin Manufacturing France SAS

4 Boulevard Eiffel 21604 LONGVIC France

위 사업장에서 제조하는 아래의 품목이 산업안전보건법 제34조 및 같은 법 시행규칙 제58조의4제4항에 따른 안전인증 심사 결과 안전·보건 기준에 적합하므로 안전인증표시의 사용을 인증합니다.

품 목

방폭구조 전기기계·기구(AC Brushless Servo Motor)

형식·모델/용량·등급/인증번호

형식·모델	인증번호
EX6a0Ebcd15ef	16-AV4BO-0498X
용량·등급	
Ex d IIB T4	
a(length): 2/3, b(Feedback): A/G/R/S/T/U/V/W/X/Y,	
c(Winding), d(Painting): R(Non)/B(Black),	
e(IP): 0(IP64)/1(IP65), f(shaft):0/1	
브레이크있음, 정격: (뒤쪽)참조	

인 증 기 준

방호장치 의무안전인증 고시(고용노동부고시 제2013-54호)

인 증 조 건

(뒤쪽)참조

2016년 12월 21일

한국산업안전보건공단 이사장



제 2016-BO-0497 호



(앞쪽)

안 전 인 증 서

Parker Hannifin Manufacturing France SAS

4 Boulevard Eiffel 21604 LONGVIC France

위 사업장에서 제조하는 아래의 품목이 산업안전보건법 제34조 및 같은 법 시행규칙 제58조의4제4항에 따른 안전인증 심사 결과 안전·보건 기준에 적합하므로 안전인증표시의 사용을 인증합니다.

품 목

방폭구조 전기기계·기구(AC Brushless Servo Motor)

형식·모델/용량·등급/인증번호

형식·모델	인증번호
EX6a0Ebcd12ef	16-AV4BO-0497X
용량·등급	
Ex d IIB T4	
a(length): 2/3, b(Feedback): A/G/R/S/T/U/V/W/X/Y,	
c(Winding), d(Painting): R(Non)/B(Black),	
e(IP): 0(IP64)/1(IP65), f(shaft):0/1	
브레이크없음, 정격: (뒤쪽)참조	

인 증 기 준

방호장치 의무안전인증 고시(고용노동부고시 제2013-54호)

인 증 조 건

(뒤쪽)참조

2016년 12월 21일

한국산업안전보건공단 이사장



제 2017-BO-0279 호



(앞쪽)

안 전 인 증 서

Parker Hannifin Manufacturing France SAS

4 Boulevard Eiffel 21604 LONGVIC France

위 사업장에서 제조하는 아래의 품목이 산업안전보건법 제34조 및 같은 법 시행규칙 제58조의4제4항에 따른 안전인증 심사 결과 안전·보건 기준에 적합하므로 안전인증표시의 사용을 인증합니다.

품 목

방폭구조 전기기계·기구(AC Brushless Servo Motor)

형식·모델/용량·등급/인증번호

형식·모델	인증번호
EX8a0Ebcd12ef	17-AV4BO-0279X
용량·등급	Ex d IIB T4
	a(length):2/4/6, b(Feedback):A/G/R/S/T/U/V/W/X/Y,
	c(Winding),d(Painting):R(Non)/B(Black),e(IP):0(IP64)/1(IP65),
	f(shaft):0/1, 브레이크없음, 정격:(뒤쪽)참조

인 증 기 준

방호장치 안전인증 고시(고용노동부고시 제2016-54호)

인 증 조 건

(뒤쪽)참조

2017년 06월 09일

한국산업안전보건공단



제 2017-BO-0280 호



(앞쪽)

안 전 인 증 서

Parker Hannifin Manufacturing France SAS

4 Boulevard Eiffel 21604 LONGVIC France

위 사업장에서 제조하는 아래의 품목이 산업안전보건법 제34조 및 같은 법 시행규칙 제58조의4제4항에 따른 안전인증 심사 결과 안전·보건 기준에 적합하므로 안전인증표시의 사용을 인증합니다.

품 목

방폭구조 전기기계·기구(AC Brushless Servo Motor)

형식·모델/용량·등급/인증번호

형식·모델	인증번호
EX8a0Ebcd15ef	17-AV4BO-0280X
용량·등급	Ex d IIB T4
	a(length):2/4/6, b(Feedback):A/G/R/S/T/U/V/W/X/Y,
	c(Winding),d(Painting):R(Non)/B(Black),e(IP):0(IP64)/1(IP65),
	f(shaft):0/1, 브레이크있음, 정격:(뒤쪽)참조

인 증 기 준

방호장치 안전인증 고시(고용노동부고시 제2016-54호)

인 증 조 건

(뒤쪽)참조

2017년 06월 09일

한국산업안전보건공단



Compliance with «UL» standards

CERTIFICATE OF COMPLIANCE

Certificate Number 20151001-E302760
Report Reference E302760-20090203
Issue Date 2015-OCTOBER-01

Issued to: PARKER HANNIFIN MANUFACTURING FRANCE SAS
ESTABLISHMENT LONGVIC
4 Bld EIFFEL
21600 LONGVIC FRANCE

This is to certify that
representative samples of

MOTORS, SPECIALTY FOR USE IN HAZARDOUS
LOCATIONS

Brushless servo motors - Models EX310, EX420, EX430,
EX620, EX630, EX 820, EX 840, EX 860 followed by U,
followed by A through Z, followed by A through Z, followed
by R, followed by 1, followed by 2 or 5, followed by code 02
through 99, for use in Hazardous (Classified) Locations,
Class I, Groups C & D.

Have been investigated by UL in accordance with the
Standard(s) indicated on this Certificate.

Standard(s) for Safety: UL 674, Electric Motors and Generators for Use in Division
1 Hazardous (Classified) Locations.
CAN/CSA C22.2 No. 145-M1986, Motors and Generators
for Use in Hazardous Locations .

Additional Information: See the UL Online Certifications Directory at
www.ul.com/database for additional information

Only those products bearing the UL Certification Mark should be considered as being covered by UL's
Certification and Follow-Up Service.

Look for the UL Certification Mark on the product.



Bruce Mahenholz, Director North American Certification Program
UL LLC

Any information and documentation involving UL Mark services are provided on behalf of UL LLC (UL) or any authorized licensee of UL. For questions, please
contact a local UL Customer Service Representative at <http://www.ul.com/about/locations>.



Compliance with «UL» standards

CERTIFICATE OF COMPLIANCE

Certificate Number 20151001-E242959
Report Reference E242959-20070608
Issue Date 2015-OCTOBER-01

Issued to: PARKER HANNIFIN MANUFACTURING FRANCE SAS
ESTABLISHMENT LONGVIC
4 Bld EIFFEL
21600 LONGVIC FRANCE

This is to certify that
representative samples of

COMPONENT - INCOMPLETE ROTATING MACHINES
AND ROTATING MACHINE PARTS
COMPONENT - SERVO AND STEPPER MOTORS
Brushless servo motor - Models EX310, EX420, EX430,
EX620, EX630, EX 820, EX 840, EX 860 followed by U;
followed by A through Z, followed A through Z, followed by
R, followed by code 1 for EX3-EX4-EX6-EX8 motors,
followed by code 2 or 5 and B or E, followed by code 02
through 99

Have been investigated by UL in accordance with the
Standard(s) indicated on this Certificate.

Standard(s) for Safety: UL 1004-1, Rotating Electrical Machines - General
Requirements
C22.2 No. 100-04, Motors and Generators

Additional Information: See the UL Online Certifications Directory at
www.ul.com/database for additional information

Only those products bearing the UL Certification Mark should be considered as being covered by UL's
Certification and Follow-Up Service.

Recognized components are incomplete in certain constructional features or restricted in performance
capabilities and are intended for use as components of complete equipment submitted for investigation rather
than for direct separate installation in the field. The final acceptance of the component is dependent upon its
installation and use in complete equipment submitted to UL LLC.

Look for the UL Certification Mark on the product.

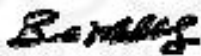

Bruce Mehenholz, Director North American Certification Program

UL LLC

Any information and documentation involving UL Mark services are provided on behalf of UL LLC (UL) or any authorized licensee of UL. For questions, please
contact a local UL Customer Service Representative at <http://ul.com/about/locations>.



Table of Content

1. INTRODUCTION	24
1.1. Purpose and intended audience	24
1.1.1. IECEx and Kosha certified motors	25
1.1.2. CCC Certified motors	28
1.2. Safety	31
1.2.1. Principle	31
1.2.2. General Safety Rules	31
1.2.3. Safe Torque Off function	33
1.2.4. Operating category and marking of EX servomotors	34
1.2.5. Special conditions for the ATEX servomotors	35
1.2.5.1. UL	36
2. PRODUCT DESCRIPTION	37
2.1. Quick URL	37
2.2. Overview	37
2.3. Applications	37
2.4. General Technical Data for ATEX/IECEx motors	38
2.5. General Technical Data for UL motors	39
2.6. Product Code	40
3. TECHNICAL DATA	41
3.1. Motor selection	41
3.1.1. EX standard atmospheric conditions	41
3.1.2. Altitude derating	41
3.1.3. Temperature derating	41
3.1.4. Thermal equivalent torque (rms torque)	41
3.1.5. Servo drive selection	43
3.1.6. Current limitation at stall conditions (i.e. speed < 3 rpm)	47
3.1.7. Peak current limitations	47
3.2. EX Characteristics: Torque, speed, current, power...	48
3.2.1. ATEX/IECEx 230V	49
3.2.2. ATEX/IECEx 400V	50
3.2.3. UL 230V	51
3.2.4. UL 400V	51
3.2.5. Further Data	52
3.2.6. Efficiency curves	53
3.2.6.2. Series EX420E (EX420EAP)	55
3.2.6.3. Series EX430E (EX430EAL)	55
3.2.6.4. Series EX620E (EX620EAO)	56
3.2.6.5. Series EX630E (EX630EAN)	56
3.2.6.6. Series EX820E (EX820EAR)	57
3.2.6.7. Series EX840E (EX840EAK)	57
3.2.6.8. Series EX860E (EX860EAJ)	58
3.2.6.9. Series EX310U (EX310UAU)	59
3.2.6.10. Series EX420U (EX420UAI)	60
3.2.6.11. Series EX430U (EX430UAG)	60
3.2.6.12. Series EX620U (EX620UAM)	61

3.2.6.13.	Series EX630U (EX630UAK)	61
3.2.6.14.	Series EX820U (EX820UAQ)	62
3.2.6.15.	Series EX840U (EX840UAL)	62
3.2.6.16.	Series EX860U (EX860UAJ)	63
3.2.7.	Electromagnetic losses	64
3.2.8.	Time constants of the motor	65
3.2.8.1.	Electric time constant:	65
3.2.8.3.	Thermal time constant of the copper:	66
3.2.9.	Speed ripple	67
3.2.10.	Cogging torque	67
3.2.11.	Rated data according to rated voltage variation	68
3.2.12.	Voltage withstand characteristics of EX series	70
3.2.13.	Voltage and current during the operating	71
3.3.	Dimension drawings	73
3.3.1.	EX310E	73
3.3.2.	EX420E EX430E	74
3.3.3.	EX620E EX630E	75
3.3.4.	EX820E EX840E EX860E	76
3.3.5.	EX310...C (CCC)	77
3.3.6.	EX420...C; EX430...C (CCC)	78
3.3.7.	EX620...C; EX630...C (CCC)	79
3.3.8.	EX820...C; EX840...C; EX860...C (CCC)	80
3.3.9.	EX310U	81
3.3.10.	EX420U EX430U	82
3.3.11.	EX620U EX630U	83
3.3.12.	EX820U EX840U EX860U	84
3.4.	Motor Mounting	85
3.4.1.	Motor mounting	85
3.4.2.	Installation of ATEX machines	85
3.4.3.	Frame recommendation	86
3.5.	Shaft Loads	87
3.5.1.	Vibration resistance to shaft end	87
3.5.2.	Maximum load acceptable on the shaft	87
3.6.	Cooling	89
3.7.	Thermal Protection	90
3.8.	Power Electrical Connections	91
3.8.1.	Inlet cables for ATEX/IECEx version.	91
3.8.2.	Wires sizes	91
3.8.3.	Conversion Awg/kcmil/mm ² :	92
3.8.4.	Motor cable length	92
3.8.5.	Mains supply connection diagrams	93
3.8.5.1.	EX310E	93
3.8.5.2.	EX420E, EX430E	94
3.8.5.3.	EX620E, EX630E	95
3.8.5.4.	EX820E, EX840E, EX860E	96
3.8.5.5.	EX310...C (CCC)	97
3.8.5.6.	EX420...C; EX430...C (CCC)	98
3.8.5.7.	EX620...C; EX630...C (CCC)	99
3.8.5.8.	EX820...C; EX840...C; EX860...C (CCC)	100
3.8.5.9.	EX310U	101
3.8.5.10.	EX420U, EX430U	102
3.8.5.11.	EX620U, EX630U	103
3.8.5.12.	EX820U, EX840U, EX860U	104
3.8.6.	ATEX/IECEx motor connection	105
3.8.6.1.	Connection of the power and the feedback cables with terminals	105
3.8.6.2.	Connection of the feedback and power cable with connector on EX3 :	107

3.8.7.	EX3-EX4 UL connection	109
3.8.7.1.	Connection of the feedback and power cable with connector:	109
3.8.8.	EX6-EX8 UL connection	111
3.8.8.1.	Connection of the feedback and power cable with terminal:	111
3.8.9.	Feedback system	113
3.8.10.	Shaft rotation regarding the connection.	113
3.8.11.	Resolver 2 poles transformation ratio = 0.5 – code A	113
3.8.12.	Sensorless – code K or Y.	113
3.8.13.	Hiperface encoder singleturn EKS3618 bits– code P	114
3.8.14.	Hiperface encoder multiturn EKM36 18 bits – code Q	114
3.8.15.	Hiperface encoder singleturn SKS36 (128pulses) – code R	115
3.8.16.	Hiperface encoder multiturn SKM36 (128pulses) – code S	115
3.9.	Cables	116
3.9.1.	Cable option Max 80°C on the surface ATEX/IECEX	117
3.9.2.	Power & Sensor cable for PSD	118
3.10.	Brake option	120
4.	COMMISSIONING, USE AND MAINTENANCE	121
4.1.	Instructions for commissioning, use and maintenance	121
4.1.1.	Equipment delivery	121
4.1.2.	Handling	121
4.1.3.	Storage	122
4.2.	Installation	122
4.2.1.	Mounting	122
4.2.2.	Torque value for the screws	122
4.2.3.	Preparation	123
4.2.4.	Mechanical assembly	123
4.3.	Electrical connections	124
4.3.1.	Cable connection	125
4.3.2.	Encoder cable handling	125
4.3.3.	Connection diagrams	126
4.3.3.1.	EX3-EX4 DC supply	126
4.3.3.2.	EX single phase	126
4.3.3.3.	EX three phase	127
4.3.4.	Cable glands informations (Only ATEX/IECEX)	128
4.3.4.1.	Technical data	128
4.3.4.2.	Torque value	129
4.3.5.	UL Electrical commissioning	130
4.4.	Maintenance Operations	131
4.4.1.	Summary maintenance operations	131
4.4.2.	Informations about the flameproof enclosure components	132
4.4.3.	ATEX flameproof joints informations ATEX/IECEX	132
4.5.	Troubleshooting	133

1. INTRODUCTION





1.1. Purpose and intended audience

This manual contains information that must be observed to select, install, operate and maintain PARKER EX servomotors.

Installation, operation and maintenance of the equipment should be carried out by qualified personnel. A qualified person is someone who is technically competent and familiar with all safety information and established safety practices; with the installation process, operation and maintenance of this equipment; and with all the hazards involved.

Reading and understanding the information described in this document is mandatory before carrying out any operation on the motors. If any malfunction or technical problem occurs, that has not been dealt with in this manual, please contact PARKER for technical assistance. In case of missing information or doubts regarding the installation procedures, safety instructions or any other issue tackled in this manual, please contact PARKER as well.

PARKER's responsibility is limited to its servomotors and does not encompass the whole user's system. Data provided in this manual are for product description only and may not be guaranteed, unless expressly mentioned in a contract.

	<p><u>DANGER:</u> PARKER declines responsibility for any accident or material damage that may arise, if the procedures and safety instructions described in this manual are not scrupulously followed.</p>
	<p><u>Motors for ATEX zones :</u> Servomotors type EX manufactured for the European market are designed to operate in ATEX classified zones</p>
	<p><u>Motors for hazardous classified locations :</u> EX servomotors manufactured for the North American market are designed to operate in hazardous classified areas.</p>
	<p><u>Motors for Ex zones :</u> Servomotors type EX manufactured off European and North American markets are designed to operate in Ex classified zones.</p>

1.1.1. IECEx and Kosha certified motors



The Kosha certification is based on IECEx certification.
The Kosha EX motors are also IECEx. Kosha / IECEx certified have a limited number of options indicated in the next tables:

	<p><u>DANGER:</u> All the instructions for the IECEx motors shall be applied to IECEx/KOSHA motors in addition to the local regulation.</p>
---	---

EX3 (IecEX and Kosha):

Code	E	X	3	1	0	E				1		
	1	2	3	4	5	6	7	8	9	10	11	
1	Product series					EX						
2	Motor size					3						
3	Motor length					10						
4	Motor version					E	ATEX / IECEx / CCC motor					
5	Feedback sensor					A	resolver 2 poles transformation ratio = 0.5					
						R	Hiperface encoder singleturn SKS36 (128pulses)					
						S	Hiperface encoder mutiturn SKM36 (128pulses)					
						Y	Sensorless					
6	Torque speed characteristics					A, B... to Z						
7	Painting					R	No painting					
						B	Black painting					
8	Electric connection					1	Cable gland					
9	Brake and thermal sensor option					2	Without brake					
						5	With brake					
10	Mechanical interface					00	IP64 Plain shaft					
						10	IP64 key on shaft					
						10	IP65 Plain shaft					
						11	IP65 key on shaft					
11	Name plate						IECEx					

EX4 (IecEX and Kosha):

Code	E	X	4		E				1			
	1	2	3	4	5	6	7	8	9	10	11	
1	Product series					EX						
2	Motor size					4						
3	Motor length					20, 30						
4	Motor version					E	ATEX / IECEx / CCC motor					
5	Feedback sensor					A	resolver 2 poles transformation ratio = 0.5					
						R	Hiperface encoder singleturn SKS36 (128pulses)					
						S	Hiperface encoder mutiturn SKM36 (128pulses)					
						T	Hiperface encoder singleturn SRS50 (1024pulses)					
						U	Hiperface encoder mutiturn SRM50 (1024pulses)					
						Y	Sensorless					
6	Torque speed characteristics					A, B... to Z						
7	Painting					R	No painting					
						B	Black painting					
8	Electric connection					1	Cable gland					
9	Brake and thermal sensor option					2	Without brake					
						5	With brake					
10	Mechanical interface					00	IP64 Plain shaft					
						10	IP64 key on shaft					
						10	IP65 Plain shaft					
						11	IP65 key on shaft					
11	Name plate						IECEx					

EX6 (IecEX and Kosha):

Code	E	X	6		E					1		
	1	2	3		4	5	6	7	8	9	10	11
1	Product series				EX							
2	Motor size				6							
3	Motor length				20, 30							
4	Motor version				E		ATEX / IECEx / CCC motor					
5	Feedback sensor				A		resolver 2 poles transformation ratio = 0.5					
					R		Hiperface encoder singleturn SKS36 (128pulses)					
					S		Hiperface encoder mutiturn SKM36 (128pulses)					
					T		Hiperface encoder singleturn SRS50 (1024pulses)					
					U		Hiperface encoder mutiturn SRM50 (1024pulses)					
					Y		Sensorless					
6	Torque speed characteristics				A, B... to Z							
7	Painting				R		No painting					
					B		Black painting					
8	Electric connection				1		Cable gland					
9	Brake and thermal sensor option				2		Without brake					
					5		With brake					
10	Mechanical interface				00		IP64 Plain shaft					
					10		IP64 key on shaft					
					10		IP65 Plain shaft					
					11		IP65 key on shaft					
11	Name plate						IECEx					

EX8 (IecEX and Kosha):

Code	E	X	8		E					1		
	1	2	3		4	5	6	7	8	9	10	11
1	Product series				EX							
2	Motor size				8							
3	Motor length				20, 40, 60							
4	Motor version				E		ATEX / IECEx / CCC motor					
5	Feedback sensor				A		resolver 2 poles transformation ratio = 0.5					
					R		Hiperface encoder singleturn SKS36 (128pulses)					
					S		Hiperface encoder mutiturn SKM36 (128pulses)					
					T		Hiperface encoder singleturn SRS50 (1024pulses)					
					U		Hiperface encoder mutiturn SRM50 (1024pulses)					
					Y		Sensorless					
6	Torque speed characteristics				A, B... to Z							
7	Painting				B		Black painting					
8	Electric connection				1		Cable gland					
9	Brake and thermal sensor option				2		Without brake					
					5		With brake					
10	Mechanical interface				00		IP64 Plain shaft					
					10		IP64 key on shaft					
					10		IP65 Plain shaft					
					11		IP65 key on shaft					
11	Name plate						IECEx					

1.1.2. CCC Certified motors



The CCC EX motors are verified and certified according to CNCA-C23-01: 2019 China Compulsory Certification Implementation Rule on Explosion Protected Electrical Product and CNEX-C2301-2019 Guideline of China Compulsory Certification Implementation Rule on Explosion Protected Electrical Product. The reference standard are : GB3836.1-2010; GB3836.2-2010; GB12476.1-2013; GB12476.5-2013.

CCC: "CCC" motors have exactly **the same construction as IECEx motors** (with the exception of a specific nameplate). **They are intended for use in the same areas (gas or dust) and have the same degree of safety.** Refer to standards GB3836.1-2010, GB3836.2-2010, GB12476.1-2013, GB12476.5-2013, the CNCA-C23-01: 2019 and the CNEX-C2301-2019 for detailed informations.

The **CCC EX have a specific name plate** that bears only the CCC certification. All the EX with a CCC certificate have a C at the end of the part number to differentiate them to the "IECEx" EX motors

	<p><u>DANGER:</u> All the instructions for the IECEx motors shall be applied to CCC motors in addition to the local regulation, the standards GB3836.1-2010; GB3836.2-2010; GB12476.1-2013; GB12476.5-2013, the CNCA-C23-01: 2019 and the CNEX-C2301-2019</p>
--	--

The CCC Ex motors are marked with the following:

Ex d IIB T4 Gb IP64 (Gas)

Ex d IIB T4 Gb, Ex tD A21 IP65 T135°C (Gas and Dust)

Short explanation :

Ex d IIB T4 Gb IP64 for gas

- Ex: indicates that the electrical equipment corresponds to one or more of the types of protection which are the subject of the specific standards
- "d": flameproof enclosure,
- IIB for electrical equipment for places with an explosive gas atmosphere (Ethylene type) other than mines susceptible to firedamp.
- T4: Temperature class 4 (135°C)
- Gb: Level of protection
- IP65 : Ingress Protection Level 64

Ex tD A21 IP65 T135°C for dust

- Ex: indicates that the electrical equipment corresponds to one or more of the types of protection which are the subject of the specific standards
- "tD": dust ignition protection protection by enclosure tD
- A21: Method A, Zone 21
- IP65 : Ingress Protection Level 65
- T135°C: Temperature class

The available options for the "CCC" marked motors are those indicated in the next tables:

EX3 (CCC):

Code	E	X	3	1	0	E				1		C	
	1		2		3	4	5	6	7	8	9	10	11
1	Product series					EX							
2	Motor size					3							
3	Motor length					10							
4	Motor version					E		ATEX / IECEx / CCC motor					
5	Feedback sensor					A		resolver 2 poles transformation ratio = 0.5					
						P		DSL encoder singleturn EKS36 – SIL2					
						Q		DSL encoder multiturn EKM36 – SIL2					
						R		Hiperface encoder singleturn SKS36 (128pulses)					
						S		Hiperface encoder mutiturn SKM36 (128pulses)					
						Y		Sensorless					
6	Torque speed characteristics					A, B... to Z							
7	Painting					R		No painting					
						B		Black painting					
8	Electric connection					1		Cable gland					
9	Brake and thermal sensor option					2		Without brake					
						5		With brake					
10	Mechanical interface					00		IP64 Plain shaft					
						10		IP64 key on shaft					
						10		IP65 Plain shaft					
						11		IP65 key on shaft					
11	Name plate					C		CCC					

EX4 (CCC):

Code	E	X	4			E				1		C	
	1		2		3	4	5	6	7	8	9	10	11
1	Product series					EX							
2	Motor size					4							
3	Motor length					20, 30							
4	Motor version					E		ATEX / IECEx / CCC motor					
5	Feedback sensor					A		resolver 2 poles transformation ratio = 0.5					
						P		DSL encoder singleturn EKS36 – SIL2					
						Q		DSL encoder multiturn EKM36 – SIL2					
						R		Hiperface encoder singleturn SKS36 (128pulses)					
						S		Hiperface encoder mutiturn SKM36 (128pulses)					
						T		Hiperface encoder singleturn SRS50 (1024pulses)					
						U		Hiperface encoder mutiturn SRM50 (1024pulses)					
						Y		Sensorless					
6	Torque speed characteristics					A, B... to Z							
7	Painting					R		No painting					
						B		Black painting					
8	Electric connection					1		Cable gland					
9	Brake and thermal sensor option					2		Without brake					
						5		With brake					
10	Mechanical interface					00		IP64 Plain shaft					
						10		IP64 key on shaft					
						10		IP65 Plain shaft					
						11		IP65 key on shaft					
11	Name plate					C		CCC					

EX6 (CCC):

Code	E	X	6		E					1		C
	1	2	3	4	5	6	7	8	9	10	11	
1	Product series				EX							
2	Motor size				6							
3	Motor length				20, 30							
4	Motor version				E		ATEX / IECEx / CCC motor					
5	Feedback sensor				A		resolver 2 poles transformation ratio = 0.5					
					P		DSL encoder singleturn EKS36 – SIL2					
					Q		DSL encoder multiturn EKM36 – SIL2					
					R		Hiperface encoder singleturn SKS36 (128pulses)					
					S		Hiperface encoder mutiturn SKM36 (128pulses)					
					T		Hiperface encoder singleturn SRS50 (1024pulses)					
					U		Hiperface encoder mutiturn SRM50 (1024pulses)					
					Y		Sensorless					
6	Torque speed characteristics				A, B... to Z							
7	Painting				R		No painting					
					B		Black painting					
8	Electric connection				1		Cable gland					
9	Brake and thermal sensor option				2		Without brake					
					5		With brake					
10	Mechanical interface				00		IP64 Plain shaft					
					10		IP64 key on shaft					
					10		IP65 Plain shaft					
					11		IP65 key on shaft					
11	Name plate				C		CCC					

EX8 (CCC):

Code	E	X	8		E					1		C
	1	2	3	4	5	6	7	8	9	10	11	
1	Product series				EX							
2	Motor size				8							
3	Motor length				20, 40, 60							
4	Motor version				E		ATEX / IECEx / CCC motor					
5	Feedback sensor				A		resolver 2 poles transformation ratio = 0.5					
					P		DSL encoder singleturn EKS36 – SIL2					
					Q		DSL encoder multiturn EKM36 – SIL2					
					R		Hiperface encoder singleturn SKS36 (128pulses)					
					S		Hiperface encoder mutiturn SKM36 (128pulses)					
					T		Hiperface encoder singleturn SRS50 (1024pulses)					
					U		Hiperface encoder mutiturn SRM50 (1024pulses)					
					Y		Sensorless					
6	Torque speed characteristics				A, B... to Z							
7	Painting				B		Black painting					
8	Electric connection				1		Cable gland					
9	Brake and thermal sensor option				2		Without brake					
					5		With brake					
10	Mechanical interface				00		IP64 Plain shaft					
					10		IP64 key on shaft					
					10		IP65 Plain shaft					
					11		IP65 key on shaft					
11	Name plate				C		CCC					



1.2. Safety





1.2.1. Principle

To operate safely, this equipment must be transported, stored, handled, installed and serviced correctly. Following the safety instructions described in each section of this document is mandatory. Servomotors usage must also comply with all applicable standards, national directives and factory instructions in force.

	<p><u>DANGER:</u> Non-compliance with safety instructions, legal and technical regulations in force may lead to physical injuries or death, as well as damages to the property and the environment.</p>
---	--

1.2.2. General Safety Rules

	<p>Generality <u>DANGER:</u> The installation, commission and operation must be performed by qualified personnel, in conjunction with this documentation.</p> <p>The qualified personnel must know the safety (C18510 authorization, standard VDE 0105 or IEC 0364) and local regulations.</p> <p>They must be authorized to install, commission and operate in accordance with established practices and standards.</p>
	<p>Electrical hazard</p> <p>Servo drives may contain non-insulated live AC or DC components. Respect the drives commissioning manual. Users are advised to guard against access to live parts before installing the equipment.</p> <p>Some parts of the motor or installation elements can be subjected to dangerous voltages, when the motor is driven by the inverter , when the motor rotor is manually rotated, when the motor is driven by its load, when the motor is at standstill or stopped.</p> <p>For measurements use only a meter to IEC 61010 (CAT III or higher). Always begin using the highest range. CAT I and CAT II meters must not be used on this product.</p> <p>Allow at least 5 minutes for the drive's capacitors to discharge to safe voltage levels (<50V). Use the specified meter capable of measuring up to 1000V dc & ac rms to confirm that less than 50V is present between all power terminals and between power terminals and earth.</p> <p>The motor must be permanently connected to an appropriate safety earth. The continuity of the grounding circuit has to be checked on the complete circuit : the resistance between any conductive point and the grounding conductor shall not exceed more than 100mΩ.</p> <p>To prevent any accidental contact with live components, it is necessary to check that cables are not damaged, stripped or not in contact with a rotating part of the machine. The work place must be clean, dry.</p> <p>General recommendations :</p> <ul style="list-style-type: none"> - Check the wiring circuit - Lock the electrical cabinets - Use standardized equipment.

	<p>Mechanical hazard Servomotors can accelerate in milliseconds. Running the motor can lead to other sections of the machine moving dangerously. Moving parts must be screened off to prevent operators coming into contact with them. The working procedure must allow the operator to keep well clear of the danger area.</p>
	<p>Burning Hazard Always bear in mind that some parts of the surface of the motor can reach a temperature of 135°C.</p>
	<p>Atex servomotors This motor can be used in hazardous areas. May particular attention to the notes marked with  .</p>
	<p>European directive 99/92/EC makes explicit the responsibility of employers to protect employees who may be exposed to risk of ATEX environments (Explosive Atmosphere). The employer must assess the risk and classify potentially dangerous areas. Equipment and materials must also be suited for use in dangerous areas in accordance with ATEX directives 94/9/EC and 2014/34/EU.</p>

1.2.3. Safe Torque Off function

The safe torque off function in accordance with the standards EN ISO 13849-1 : 2006 and EN 61800-5-2 : 2006 is an electronic system set up on some drives certified by a notified body. This is an unlocked input placed on the drive that must be connected (see the commissioning and use manual of the drive).

The servomotors EX are equipped with a thermal protection which is checked by a safety analysis and is a key element of the ATEX/IECEX safety. It is possible to connect this protection to the unlocked input or through a safety system in accordance to the drive specifications. This connection allows to maintain the drive power on, but disable the motor after the activation of the thermal protection.

After an activation of this security device, the system must not restart automatically and without a checking of the installation.

In all cases, the connection of this device must be checked and certified by a notified body.

1.2.4. Operating category and marking of EX servomotors

1.2.4.1. EX ATEX/IECEX gaseous atmospheres



II 2 G Ex db IIB T4 Gb IP64

II		2	G	Ex	db	II	B	T4	Gb	IP65
I Mines	M1 Very high level of protection	G Gas/Vapour	ATEX protection	o Oil immersion	I Mines	Methane	T1 450 °C	Ma Very high level of protection	IP64	
	M2 High level of protection			p Pressurized apparatus			T2 300 °C	Mb High level of protection		
II Surface	1 Very high level of protection			db Flameproof enclosure	II Surface Gas	A Propane	T3 200 °C	Ga Very high level of protection		
	2 High level of protection			e Increased safety		B Ethylene	T4 135 °C	Gb High level of protection		
	3 Normal level of protection			m Encapsulation		C Hydrogen Acetylene	T5 100 °C	Gc Normal level of protection		
				i Intrinsic safety			T6 85 °C			
IP65										

Suitable for ATEX/IECEX servomotors

1.2.4.2. EX ATEX/IECEX gaseous or dusty atmospheres



II 2 GD Ex db IIB T4 Gb IP65 / Ex tb IIIC T135°C Db IP65

II	2	D	Ex	tb	III	C	T135 °C	Db	IP65
I Mines	M1 Very high level of protection	D Combustible dust	ATEX protection	ta Protection by enclosure	III Dust	A Combustible flying	T1 450 °C	Ma Very high level of protection	IP65
	M2 High level of protection			tb / tc Protection by enclosure			T2 300 °C	Mb High level of protection	
II Surface	1 Very high level of protection			B Non conductive dust		pb / pc Pressurized enclosure	T3 200 °C	Da Very high level of protection	
	2 High level of protection					ia / ib / ic Intrinsic safety	T4 135 °C	Db High level of protection	
	3 Normal level of protection					ma / mb / mc Encapsulation	T5 100 °C	Dc Normal level of protection	
				T6 85 °C					

Suitable for ATEX/IECEX servomotors

1.2.5. Special conditions for the ATEX servomotors

	<p>The EC certifications are marked with a X. It seems the using of the motor must be in accordance with special conditions explained below:</p> <p>In case of fail of a screw used to assemble the parts of the flameproof enclosure, the new part must have a quality class superior or equal to 8.8 for EX3-EX4-EX6 and superior or equal to 12.9 for EX8.</p> <p>In case of an using in dusty explosive atmospheres, the user must perform regular cleaning operations on the motor to avoid dust deposits.</p>
--	--

1.2.5.1. UL



Class1 group C&D Code T4A

Class I	Division 1	Group C&D	T4A	IP65
Class I Gaz, vapours ou liquids	Division 1 Explosive atmospheres can exist all the time or some of the time under normal operating conditions	A Acetylene	T1 450°C	IP65
		B Hydrogen	T2 300°C	
			T3 200°C	
	Division 2 Explosive atmospheres cannot exist under normal operating conditions	C Ethylene	T4 135°C	
			T4A 120°C	
		D Propane	T5 100°C	
T6 85°C				

Suitable for UL servomotors

2. PRODUCT DESCRIPTION

2.1. Quick URL

All informations and datas are available on :

<http://www.parker.com/eme/ex>

2.2. Overview

The EX servomotors from Parker are specifically designed to operate in explosive atmospheres for industrial applications.

The EX motors are brushless synchronous servomotors, with permanent magnets, based on NX active parts.

The EX motors are not designed to operate in outside environment conditions.

A large set of torque / speed characteristics, options and customization possibilities are available, making EX servomotors the ideal solution for most servosystems applications in explosive atmospheres.

Advantages

- High precision
- High motion quality
- High dynamic performances
- Low cogging
- Compact dimensions and robustness
- Large set of options and customization possibilities
- CE, IECEx and UL marking certification available.

2.3. Applications

Painting applications

Packaging machinery

Robot applications

Special machines

Cleaning applications

Printing applications

Actuator for valve in Oil&Gas and Energy applications

2.4. General Technical Data for ATEX/IECEX motors

	EX3, EX4, EX6	EX8
Motor type	Permanent-magnet synchronous motor	
Magnets material	Neodymium Iron Boron	
Number of poles	10	
Type of construction	IMB5 – IMV1 – IMV3 (EN60034-7)	
Degree of protection	<ul style="list-style-type: none"> • Gaseous atmosphere : IP64 on request, IP65 • Combustible dust atmosphere : IP65 	
Cooling	Natural cooling	
Rated voltage	230VAC, 400 VAC	
Insulation of the stator winding	Class F according to IEC 60034-1	Class F according to IEC 60034-1 with potting
Altitude	Up to 1000m (IEC 60034-1) No allowed for higher altitude	
Ambiant temperature	-20°C to +40°C -20°C to +60°C with performances derating	
Storage temperature	-20°C to +60°C	
Connection	Electronic plate with cable glands	
Marking	CE and IECEX	
Paint	Black RAL9005	
Sensor	<ul style="list-style-type: none"> • Resolver as a standard • Sick encoder – Hiperface & DSL SKS36 and SKM36 SIL2 EKS and EKM36 SIL2 • Sensorless 	
Brake	Parking brake as an option	
Thermal protection	Thermoswitches + thermofuse	
Remark	Numerous customization are possible on request (special shaft, special flange,...)	

2.5. General Technical Data for UL motors

	EX3, EX4, EX6	EX8
Motor type	Permanent-magnet synchronous motor	
Magnets material	Neodymium Iron Boron	
Number of poles	10	
Type of construction	IMB5 – IMV1 – IMV3 (CEI 60034-7)	
Degree of protection	IP65	
Cooling	Natural cooling	
Rated voltage	230VAC, 400 VAC, 480 VAC	
Insulation of the stator winding	Class F according to IEC 60034-1	Class F according to IEC 60034-1 with potting
Altitude	Up to 1000m (IEC 60034-1)	
Ambiant temperature	-20°C to +40°C	
Storage temperature	-20°C to +60°C	
Connection	Electronic plate with threaded holes	
Marking	UL	
Paint	Without	
Sensor	<ul style="list-style-type: none"> • Resolver as a standard • Sick encoder - Hiperface: SKS36 and SKM36 SIL2 • Sensorless 	
Brake	Parking brake in option	
Thermal protection	Thermoswitches + thermofuse	
Remark	Numerous customization are possible on request (special shaft, special flange,...)	



2.6. Product Code

The EX servomotors are defined by its electrical and mechanical characteristics, by its accompanying accessories and by any customer specificity. This information is coded and entered in the “Type” column on the manufacturer’s plate for the basic codification; the specificities are entered in a separate column (Check option available for each certification).

Code	E	X	3	1	0	E	A	K	R	1	2	0	0	
Product Series	E X		3 1		0 E		A K		R 1		2 0		0 0	
Motor size 1, 2, 3, 4, 6 or 8 in relation with the motor diameter	E X		3 1		0 E		A K		R 1		2 0		0 0	
Motor length up to 60 depend on size	E X		3 1		0 E		A K		R 1		2 0		0 0	
Motor version E: ATEX/IECEX motor U: UL motor	E X		3 1		0 E		A K		R 1		2 0		0 0	
Feedback Sensor A: resolver 2 poles transformation ratio = 0.5 P: DSL encoder singleturn EKS36 – SIL2 (Not for UL) Q: DSL encoder multiturn EKM36 – SIL2 (Not for UL) R: Hiperface singleturn SKS36 – SIL2 (128pulses) S: Hiperface mutiturn SKM36 – SIL2 (128pulses) request Y: sensorless Z : Special encoder	E X		3 1		0 E		A K		R 1		2 0		0 0	
Torque / Speed Characteristics See motor data	E X		3 1		0 E		A K		R 1		2 0		0 0	
Painting R: no painting B: Black painting	E X		3 1		0 E		A K		R 1		2 0		0 0	
Electric connection 1: Cable gland or threaded holes (UL)	E X		3 1		0 E		A K		R 1		2 0		0 0	
Break and thermal sensor option 2: Without brake 5: With brake	E X		3 1		0 E		A K		R 1		2 0		0 0	
Mechanical Interface 00: IP64 plain shaft on request 01: IP64 key on shaft on request 10: IP65 with plain shaft 11: IP65 with key on shaft Other: custom code	E X		3 1		0 E		A K		R 1		2 0		0 0	
Name Plate Blank : ATEX/IECEX/UL C: CCC name plate	E X		3 1		0 E		A K		R 1		2 0		0 0	

3. TECHNICAL DATA

3.1. Motor selection

3.1.1. EX standard atmospheric conditions

EX motors are designed to operate in inside area:

- with a pressure between 80 kPa (0.8 bar) and 110 kPa (1.1 bar).
- air with normal oxygen content, typically 21 % v/v.
- air with a maximum relative humidity of 80%, without condensation.

In other conditions, like outside environment, please consult us.

3.1.2. Altitude derating

From 0 to 1000 m : no derating

> 1000 m : the EX motors are not designed to operate in hazardous area for this altitude.

3.1.3. Temperature derating

EX servomotors are designed to operate with a maximum ambient temperature of 40°C. In case of using with an ambient temperature above 40°C and less or equal than 60°C, a derating of performances is applied according to data recommended by Parker.

3.1.4. Thermal equivalent torque (rms torque)

The selection of the right motor can be made through the calculation of the rms torque M_{rms} (i.e. root mean squared torque) (sometimes called equivalent torque).

This calculation does not take into account the thermal time constant. It can be used only if the overload time is much shorter than the copper thermal time constant.

The rms torque M_{rms} reflects the heating of the motor during its duty cycle.

Let us consider:

- the period of the cycle T [s],

- the successively samples of movements i characterized each ones by the maximal torque M_i [Nm] reached during the duration Δt_i [s].

So, the rms torque M_{rms} can be calculated through the following basic formula:

$$M_{rms} = \sqrt{\frac{1}{T} * \sum_{i=1}^n M_i^2 \Delta t_i}$$

Example:

For a cycle of 2s at 0 Nm and 2s at 10Nm and a period of 4 s, the rms torque is

$$M_{rms} = \sqrt{\frac{1}{4} * 10^2 * 2} = 7,07 Nm$$

Illustration :

Acceleration-deceleration torque: 10 Nm for 0,1 s.
 Resistant torque: 1 Nm during all the movement.
 Max-min speed: ± 2800 rpm during 0,2 s.
 Max torque provided by the motor: 11 Nm.
 rms torque: 6 Nm.

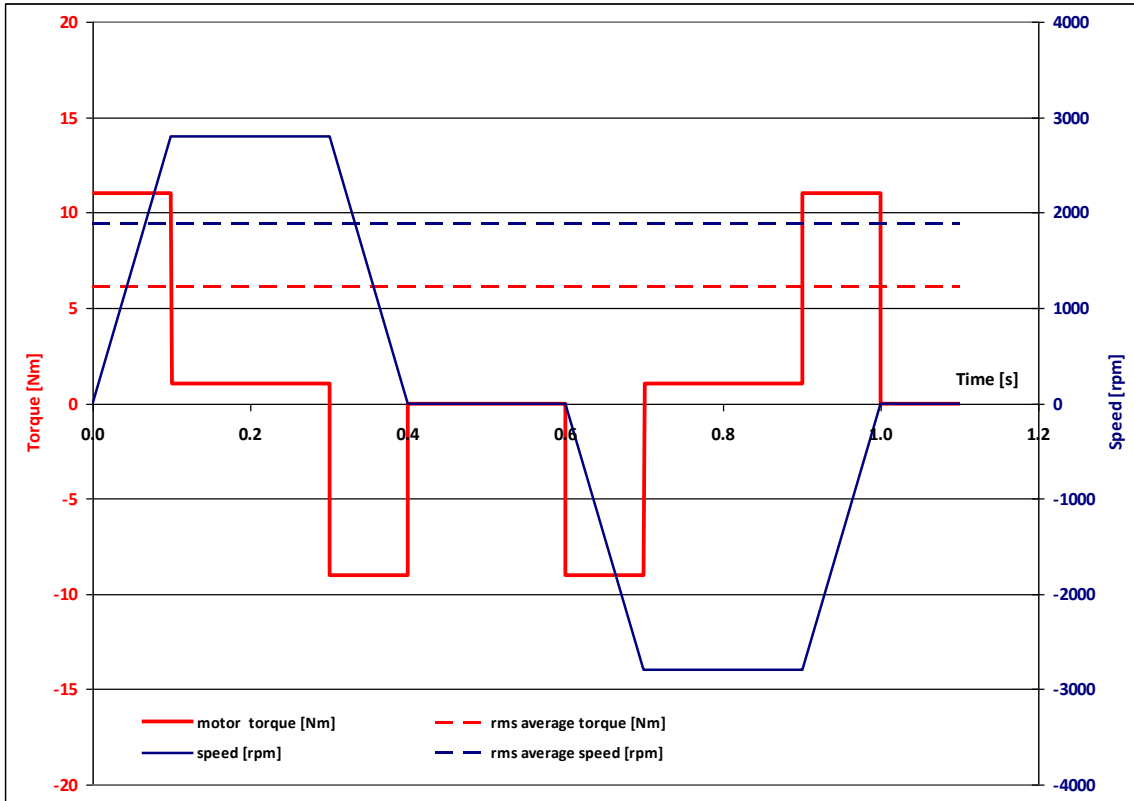

The maximal torque M_i delivered by the motor at each segment i of movement is obtained by the algebraic sum of the acceleration-deceleration torque and the resistant torque. Therefore, M_{max} corresponds to the maximal value of M_i .

Selection of the motor :

The motor adapted to the duty cycle has to provide the rms torque M_{rms} at the rms speed(*) without extra heating. This means that the permanent torque M_n available at the average speed presents a sufficient margin regarding the rms torque M_{rms} .

$$\Omega_{rms} = \sqrt{\frac{1}{T} * \sum_{i=1}^n \Omega_i^2 \Delta t_i}$$

(*) rms speed is calculated thanks to the same formula as that used for the rms torque. The mean speed cannot be used (in general mean speed is equal to zero). Only use the rms speed.

Furthermore, each M_i and speed associated Ω_i of the duty cycle has to be located in the operational area of the torque vs speed curve.

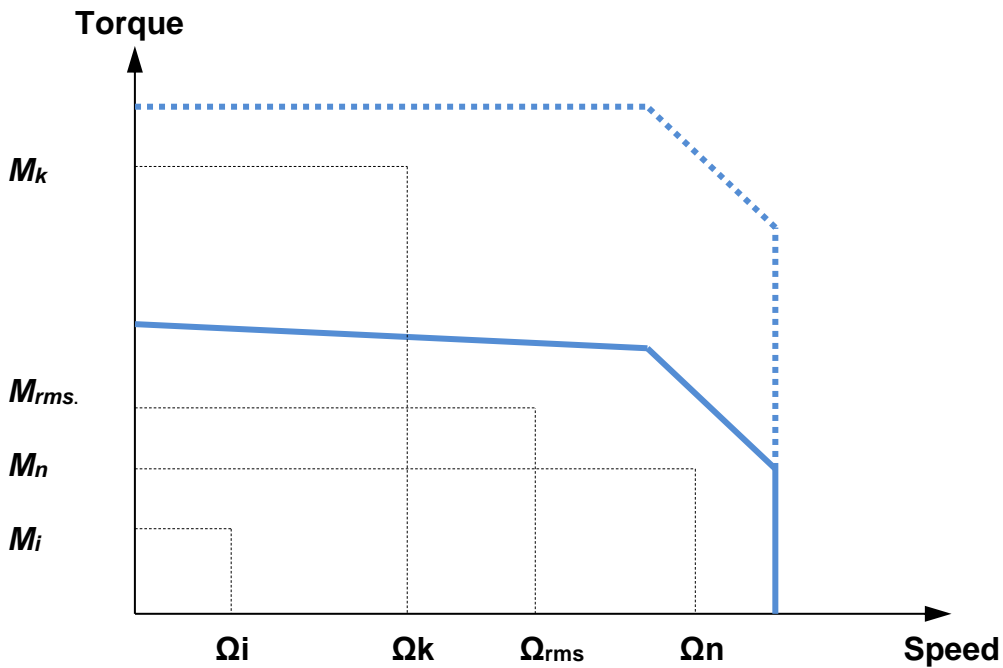

3.1.5. Servo drive selection

Selection of drive depends on its rated power, rated current and its mode selection which leads to the maximal current duration.



Please refer to the drive technical documentation for any further information and to select the best motor and drive association.



AC890 PARKER drive example:

The rated current provided by the AC890 drive depends on its rated power and its mode selection. “Vector mode” is used for induction motors while “Servo mode” is used for brushless AC motors. With EX motors the power is usually < 37 kW, the rated current corresponds to 100 %.

Power of Drive AC890 [kW]	< 37 kW
Mode	Servo mode
Overload capability [%]	200 % during 4 s

Illustration:

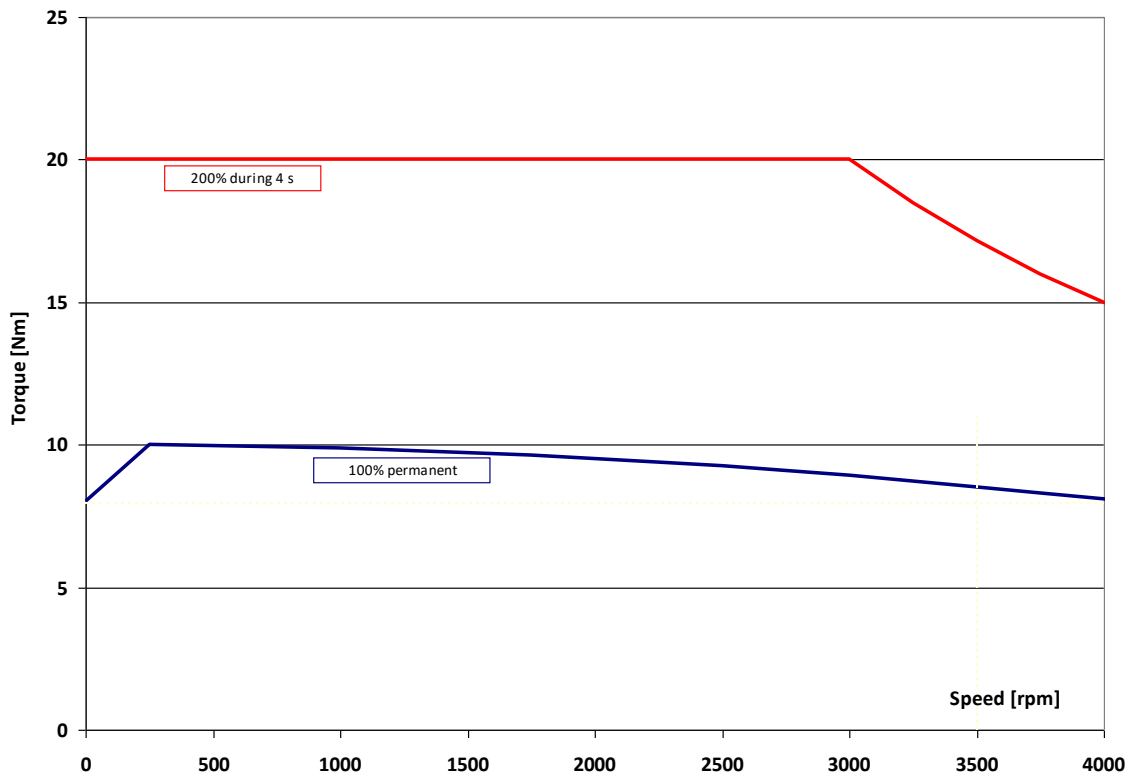



Example n°1 :

The application needs:

- a rms torque of **7 Nm** at the rms speed of 2000 rpm,
- an acceleration torque of **10 Nm**,
- a maximal speed of 2800 rpm.

Selection of the motor:

The selected motor is the type **EX620EAO**.

The nominal speed is equals to 4300 rpm.

The maximal speed is equals to 4300 rpm.

The torque sensitivity is equals to 1.27 Nm/Arms.

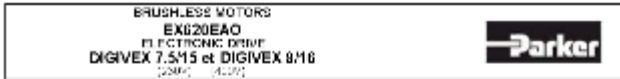

BRUSHLESS MOTORS				No UL certification	
EX620EAO					
ELECTRONIC DRIVE					
DIGIVEX 7.5M5 et DIGIVEX 8M6					
(220V - 400V)					
Torque at low speed	M_0	Nm	7		
Permanent current at low speed	I_0	Arms	5.51		
Peak torque	M_n	Nm	14.7	-	
Current for the peak torque	I_n	Arms	11.3	-	
Back emf constant at 1000 rpm (25°C)*	K_e	V/rpm	21.7		
Torque sensitivity	K_t	Nm/Arms	1.27		
Winding resistance (25°C)*	R_s	Ω	1.65		
Winding inductance*	L_s	mH	34		
Motor inertia	J	kgm ² 10 ⁻⁴	98		
Thermal time constant	τ_{th}	min	27		
Motor mass	M	kg	11.3		
Voltage of the mains	U ₁ / U ₂ / U ₃	Vrms	230	400	-
Rated speed	n_n (rpm)	rpm	2500	4300	-
Rated torque	M_n (Nm)	Nm	3.49	3.13	-
Rated current	I_n (Arms)	Arms	4.47	2.75	-
Rated power	P_n (W)	W	1440	1410	-

* All data are given at 25°C unless otherwise indicated.
 * Data by motor
 * Voltage and frequency are given in rms value

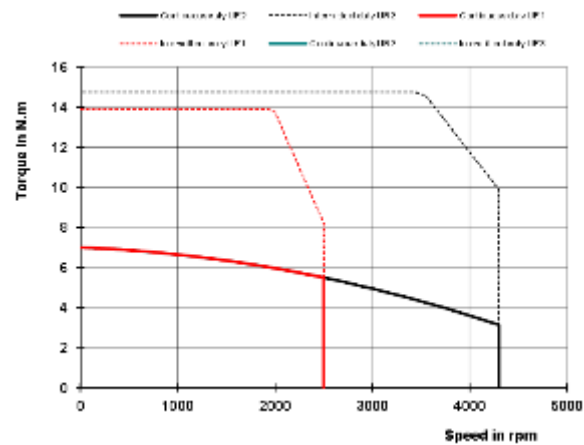

The permanent current I_0 of the motor is **5.51 Arms** for $M_0=7$ Nm at low speed.

The nominal current I_n of the motor is **2.46 Arms** for $M_n= 3.13$ Nm at the nominal speed.

Selection of the drive:

The drive has to provide at least a permanent current equals to I_0 (5.51 Arms).

In order to obtain an acceleration torque of **10 Nm**, the current will be about 8 Arms. This means that the drive has to provide at least 8 Arms as transient current.

→ Therefore, we can select the drive **AC890SD-53 2100 B** which delivers under 400 VAC:

6 Arms as permanent current and

6*200%=12 Arms as maximal transient current during 4 s.

The drive is set with **“Servo Mode”**.

Example n°2 :

This times; the application needs :

- a permanent torque of 5 Nm at low speed,
- a rms torque of 5 Nm at the rms speed of 1890 rpm,
- an acceleration torque of **7.6 Nm**,
- a maximal speed of 2800 rpm.

Selection of the motor:

The selected motor is the type **EX620EAO**.

The nominal speed is equals to 4300 rpm.

The maximal speed is equals to 4300 rpm.

The torque sensitivity is equals to 1.27 Nm/Arms.

Selection of the drive:

The drive has to provide a permanent current equals to 4 Arms to obtain 5 Nm.

In order to obtain an acceleration torque of **7.6 Nm**, the current will be of about 6 Arms

This means that the drive has to provide at less 6 Arms as transient current.

Compared to the previous example n°1, it is now possible to decrease the size of drive.

→ Therefore, we can select the drive **AC890SD-53 1600 B** which delivers under 400 VAC:

4 Arms as permanent current and

4*200%=8 Arms as maximal transient current during 4 s.

The drive is set with "**Servo Mode**".

3.1.6. Current limitation at stall conditions (i.e. speed < 3 rpm)

Recommended reduced current at speed < 3 rpm:

$$I_{reduced} = \frac{1}{\sqrt{2}} * I_0 \cong 0.7 * I_0$$

	Warning: The current must be limited to the prescribed values. If the nominal torque has to be maintained at stop or low speed (< 3 rpm), imperatively limit the current to 70% of I_0 (permanent current at low speed), in order to avoid an excessive overheating of the motor.
	Please refer to the drive technical documentation for any further information and to choose functions to program the drive.

3.1.7. Peak current limitations

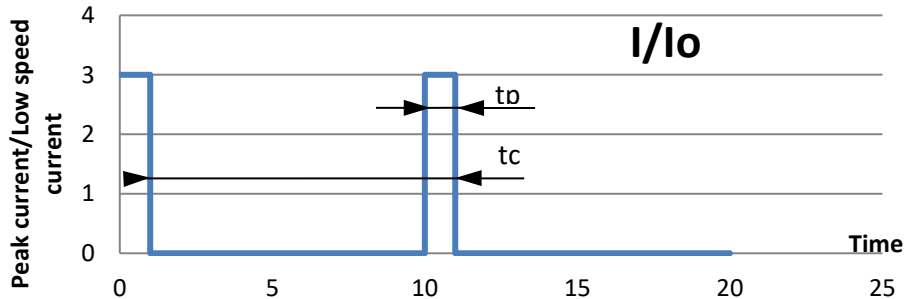

It is possible to use the EX motor with a current higher than the permanent current. But, to avoid any overheating, the following rules must be respected.

- 1) The peak currents and peak torques given in the data sheet must never be exceeded
- 2) The thermal equivalent torque must be respected (§3.1.3)
- 3) If 1) and 2) are respected (it can limit the peak current value or duration), the peak current duration (t_p) must be limited, in addition, accordingly to the following table (I_0 is the permanent current at low speed):

I_{peak}/I_n	$I_p/I_0 = 2$	$I_p/I_0 = 3$
EX310	$t_p < 0.8 \text{ s}$	$t_p < 0.3 \text{ s}$
EX420		
EX430		
EX620	$t_p < 1.5 \text{ s}$	$t_p < 0.6 \text{ s}$
EX630		
EX820		
EX840		
EX860		

The peak current duration is calculated for a temperature rise of 3°C
Consult us for more demanding applications.

3.2. EX Characteristics: Torque, speed, current, power...

The torque vs speed graph below explains different intrinsic values of the next tables.

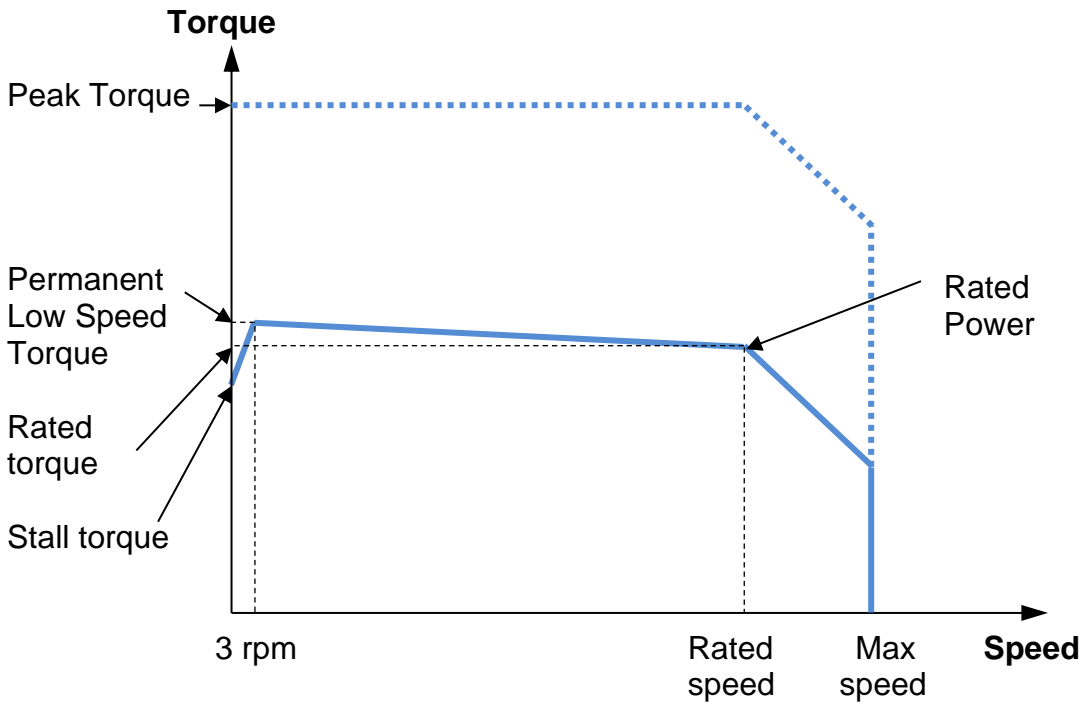

3.2.1. ATEX/IECEX 230V

Motor	Rated Power	Rated Torque	Rated Speed	Rated Current	Low Speed Torque	Low speed Current	Peak Torque	Peak Current	Max. Speed
	Pn (kW)	Mn (Nm)	Nn [rpm]	In [Arms]	Mo [Nm]	Io [Arms]	Mpeak [Nm]	I peak [Arms]	Nmax [rpm]
With 40°C ambient temperature									
EX310EAP	0.40	1.66	2300	1.2	1.75	1.2	4.2	3.1	2300
EX310EAK	0.64	1.54	4000	2.0	1.75	2.2	4.2	5.4	4000
EX420EAP	0.77	3.18	2300	2.3	3.5	2.5	8.3	6.2	2300
EX420EAJ	1.12	2.67	4000	3.3	3.5	4.3	8.3	10.7	4000
EX430EAL	1.02	4.2	2300	3.0	4.8	3.3	11.5	8.3	2300
EX430EAF	1.37	3.3	4000	4.1	4.8	5.8	11.5	14.5	4000
EX620EAV	0.76	6.6	1100	2.4	6.7	2.4	16.7	6.0	1100
EX620EAR	1.33	5.8	2200	4.0	6.7	4.5	16.7	11.2	2200
EX630EAR	1.43	9.4	1450	4.2	10.4	4.6	25.9	11.5	1450
EX630EAN	2.02	8.4	2300	5.7	10.4	6.9	25.9	17.3	2300
EX820EAR	2.57	11.2	2200	7.5	14	9.3	32.5	23.2	2200
EX840EAK	3.31	15.8	2000	9.4	24.5	14.3	58.2	35.6	2000
EX860EAJ	3.86	25.4	1450	11.5	35	15.7	83.3	39.2	1450

Motor	Rated Power	Rated Torque	Rated Speed	Rated Current	Low Speed Torque	Low speed Current	Peak Torque	Peak Current	Max. Speed
	Pn (kW)	Mn (Nm)	Nn [rpm]	In [Arms]	Mo [Nm]	Io [Arms]	Mpeak [Nm]	I peak [Arms]	Nmax [rpm]
With 60°C ambient temperature									
EX310EAP	0.31	1.30	2300	0.9	1.5	1.1	3.7	2.7	2300
EX310EAK	0.40	0.95	4000	1.3	1.5	1.9	3.7	4.6	4000
EX420EAP	0.59	2.45	2300	1.8	3	2.1	7.3	5.3	2300
EX420EAJ	0.63	1.5	4000	1.9	3	3.7	7.3	9.1	4000
EX430EAL	0.82	3.4	2300	2.4	4.2	2.9	10.2	7.2	2300
EX430EAF	0.90	2.9	3000	3.6	4.2	5.1	10.2	12.7	4000
EX620EAV	0.63	5.5	1100	2.0	6	2.2	15.0	5.3	1100
EX620EAR	0.88	3.8	2200	2.8	6	4.1	15.0	9.9	2200
EX630EAR	1.12	7.35	1450	3.4	9	4.0	22.5	9.8	1450
EX630EAN	1.24	5.15	2300	3.7	9	6.1	22.5	14.7	2300
EX820EAR	1.65	8.5	1850	5.8	11	7.3	26.6	18.3	2200
EX840EAK	2.23	11.5	1850	6.9	21	12.2	51.0	30.6	2000
EX860EAJ	2.74	18.0	1450	8.3	31	13.9	75.1	34.8	1450

3.2.2. ATEX/IECEX 400V

Motor	Rated Power	Rated Torque	Rated Speed	Rated Current	Low Speed Torque	Low speed Current	Peak Torque	Peak Current	Max. Speed
	Pn (kW)	Mn (Nm)	Nn [rpm]	In [Arms]	Mo [Nm]	Io [Arms]	Mpeak [Nm]	I peak [Arms]	Nmax [rpm]
With 40°C ambient temperature									
EX310EAP	0.64	1.54	4000	1.1	1.75	1.2	4.2	3.1	4000
EX310EAK	0.87	1.23	6800	1.6	1.75	2.2	4.2	5.4	6800
EX420EAP	0.94	3	3000	2.1	3.5	2.5	8.3	6.2	3000
EX420EAJ	1.11	1.8	6000	2.3	3.5	4.3	8.3	10.7	6000
EX430EAL	1.37	3.3	4000	2.3	4.8	3.3	11.5	8.3	4000
EX430EAF	1.37	3.3	4000	4.1	4.8	5.8	11.5	14.5	5800
EX620EAV	1.25	6.0	2000	2.2	6.7	2.4	16.7	6.0	2000
EX620EAR	1.53	3.8	3900	2.7	6.7	4.5	16.7	11.2	3900
EX630EAR	2.19	7.8	2700	3.5	10.4	4.6	25.9	11.5	2700
EX630EAN	2.18	5.2	4000	3.8	10.4	6.9	25.9	17.3	4000
EX820EAR	2.84	7.5	3600	5.2	14	9.3	32.5	23.2	3900
EX840EAK	0.99	2.9	3300	2.1	24.5	14.3	58.2	35.6	3500
EX860EAJ	2.35	9.0	2500	4.4	35	15.7	83.3	39.2	2600

Motor	Rated Power	Rated Torque	Rated Speed	Rated Current	Low Speed Torque	Low speed Current	Peak Torque	Peak Current	Max. Speed
	Pn (kW)	Mn (Nm)	Nn [rpm]	In [Arms]	Mo [Nm]	Io [Arms]	Mpeak [Nm]	I peak [Arms]	Nmax [rpm]
With 60°C ambient temperature									
EX310EAP	0.40	0.95	4000	0.7	1.5	1.1	3.7	2.7	4000
EX310EAK	0.40	0.95	4000	1.3	1.5	1.9	3.7	4.6	6800
EX420EAP	0.66	2.1	3000	1.5	3.0	2.1	7.3	5.3	3000
EX420EAJ	0.63	1.5	4000	1.9	3.0	3.7	7.3	9.1	6000
EX430EAL	0.90	2.9	3000	2.0	4.2	2.9	10.2	7.2	4000
EX430EAF	0.90	2.9	3000	3.6	4.2	5.1	10.2	12.7	4900
EX620EAV	0.88	4.2	2000	1.6	6.0	2.2	15.0	5.3	2000
EX620EAR	0.84	3.2	2500	2.4	6.0	4.1	15.0	9.9	3900
EX630EAR	1.18	4.5	2500	2.2	9.0	4.0	22.5	9.8	2700
EX630EAN	1.18	4.5	2500	3.3	9.0	6.1	22.5	14.7	4000
EX820EAR	1.65	8.5	1850	5.8	11.0	7.3	26.6	18.3	3900
EX840EAK	2.22	11.5	1850	6.9	21.0	12.2	51.0	30.6	2600
EX860EAJ	2.60	15.5	1600	7.2	31.0	13.9	75.1	34.8	2100

3.2.3. UL 230V

Motor	Rated Power	Rated Torque	Rated Speed	Rated Current	Low Speed Torque	Low speed Current	Peak Torque	Peak Current	Max. Speed
	Pn (kW)	Mn (Nm)	Nn [rpm]	In [Arms]	Mo [Nm]	Io [Arms]	Mpeak [Nm]	I peak [Arms]	Nmax [rpm]
With 40°C ambient temperature									
EX310UAU	0.62	1.4	4200	2.2	1.60	2.5	4.0	6.3	4200
EX420UAI	1.03	2.5	4000	3.3	3	4.2	8.0	10.8	4000
EX430UAG	1.17	3.5	3200	3.9	4.4	4.9	10.0	11.3	3200
EX620UAM	1.37	4.8	2750	4.7	6	6.0	16.0	14.8	2750
EX630UAK	2.01	7.1	2700	6.2	10	7.9	23.7	19.4	2700
EX820UAQ	2.43	10.1	2300	7.2	13	9.1	29.7	22.8	2300
EX840UAL	2.90	16.8	1650	9.0	23	12.0	56.5	32.3	1650
EX860UAJ	3.50	22.3	1500	10.0	31	13.9	78.5	37.1	1500

3.2.4. UL 400V

Motor	Rated Power	Rated Torque	Rated Speed	Rated Current	Low Speed Torque	Low speed Current	Peak Torque	Peak Current	Max. Speed
	Pn (kW)	Mn (Nm)	Nn [rpm]	In [Arms]	Mo [Nm]	Io [Arms]	Mpeak [Nm]	I peak [Arms]	Nmax [rpm]
With 40°C ambient temperature									
EX310UAU	0.82	1.0	7600	1.7	1.6	2.5	4.0	6.3	7600
EX420UAI	0.81	1.1	7000	1.6	3.2	4.2	8.0	10.8	7000
EX430UAG	1.02	1.7	5700	2.1	4.4	4.9	10.0	11.3	5700
EX620UAM	1.27	2.8	4300	3.0	6.4	6.0	16.0	14.8	4300
EX630UAK	1.92	4.4	4200	4.0	9.5	7.9	23.7	19.4	4200
EX820UAQ	2.62	7.0	3600	5.1	12.9	9.1	29.7	22.8	3600
EX840UAL	2.08	6.8	2900	3.9	22.6	12.0	56.5	32.3	2900
EX860UAJ	2.18	8.3	2500	4.0	31.4	13.9	78.5	37.1	2500

3.2.5. Further Data

Motor	Kt [Nm/Arms]	Ke [Vrms/krpm]	Inductance [mH]	Winding Resistance [ohms]	Moment of Inertia J [kgmm ²]	Polarity p [-]	Motor Thermal Time Constant tth [s]
ATEX / IECEx							
EX310EAP	1.42	88.9	62	20.7	79	10	55.9
EX310EAK	0.81	50.9	20.3	6.58	79	10	57.7
EX420EAP	1.42	89	33	7.2	290	10	71
EX420EAJ	0.821	51.4	11	2.31	290	10	73.7
EX430EAL	1.45	90.9	21	4.22	426	10	76.3
EX430EAF	0.828	51.8	6.8	1.38	426	10	75.7
EX620EAV	2.78	180	67.6	7.9	980	10	137
EX620EAR	1.48	95.7	19.2	2.24	980	10	137
EX630EAR	2.27	138	24.9	2.43	1470	10	158
EX630EAN	1.5	91.6	10.9	1.12	1470	10	150
EX820EAR	1.51	93	8.57	1.01	3200	10	137
EX840EAK	1.72	106	5.42	0.493	6200	10	170
EX860EAJ	2.23	140	6.43	0.499	9200	10	209
UL							
EX310UAU	0.652	41	13.2	4.29	79	10	61.8
EX420UAI	0.772	48.3	9.72	1.94	290	10	86
EX430UAG	0.902	56.4	8.07	1.55	426	10	93.1
EX620UAM	1.06	68.8	9.92	1.08	980	10	147
EX630UAK	1.2	73.6	7.06	0.674	1470	10	161
EX820UAQ	1.42	87.2	7.53	0.889	3200	10	154
EX840UAL	1.89	118	6.69	0.579	6200	10	207
EX860UAJ	2.26	140	6.43	0.499	9200	10	242

3.2.6. Efficiency curves



Caution: The efficiency curves are typical values. They may vary from one motor to another



Caution: The efficiency curves are given for an optimal motor control (no voltage saturation and optimal phase between current and EMF)



Caution: The efficiency curves do not include the losses due to the switching frequency.



3.2.6.1. Series EX310E (EX310EAP)

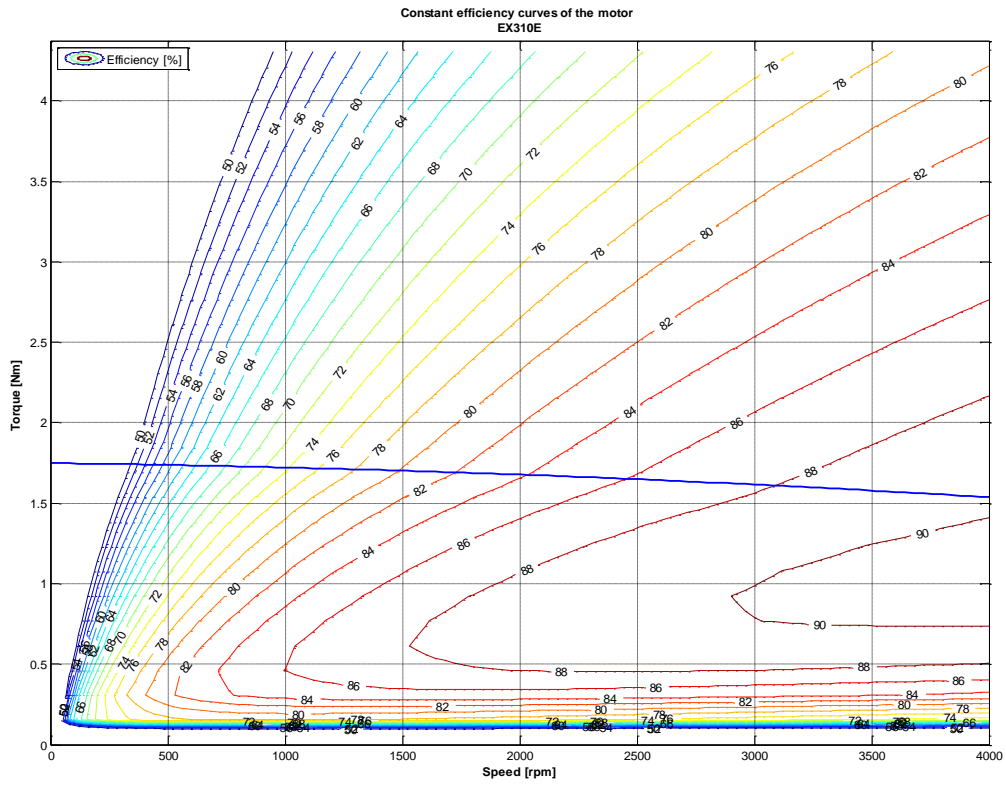

3.2.6.2. Series EX420E (EX420EAP)

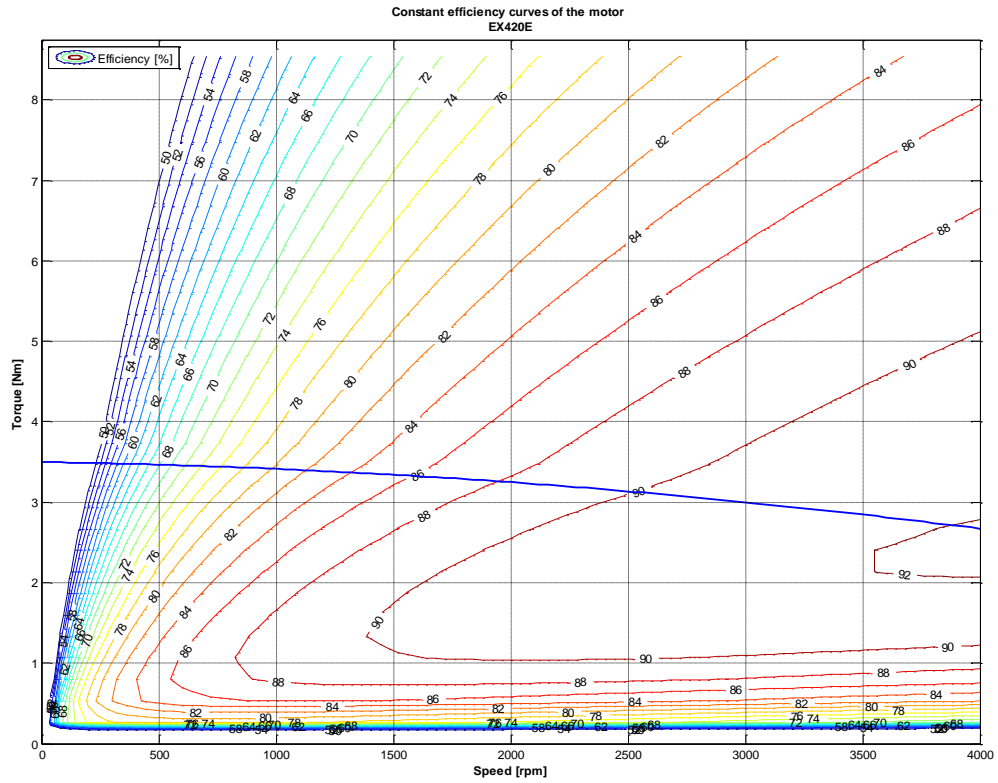

3.2.6.3. Series EX430E (EX430EAL)

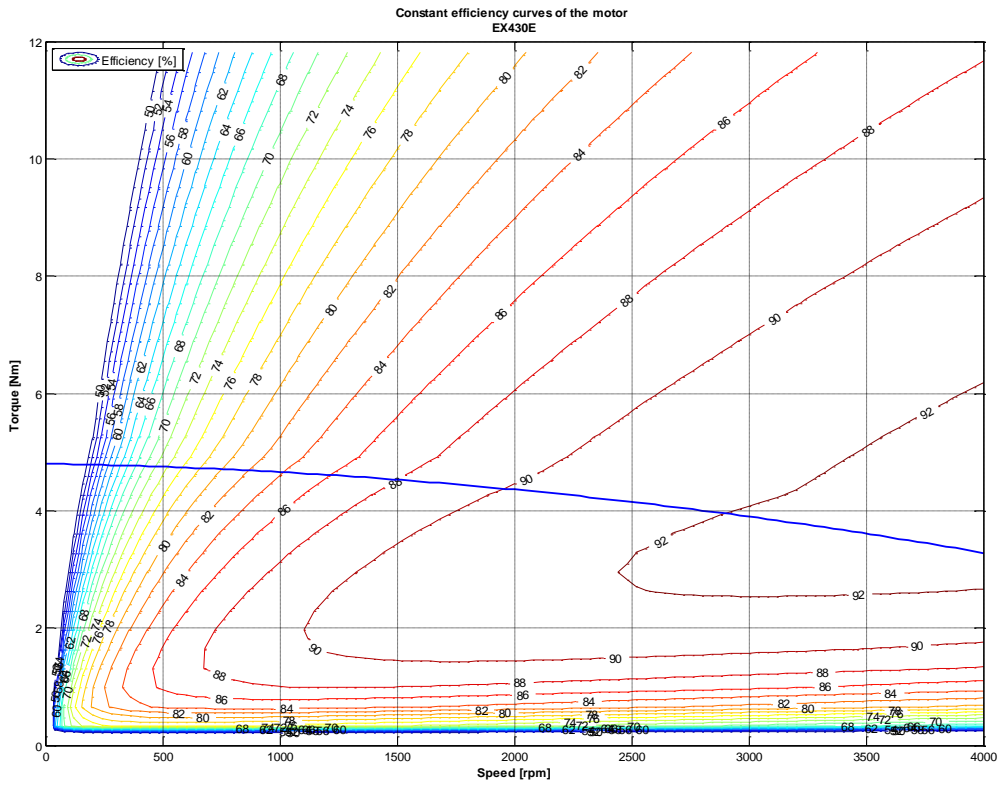

3.2.6.4. Series EX620E (EX620EAO)

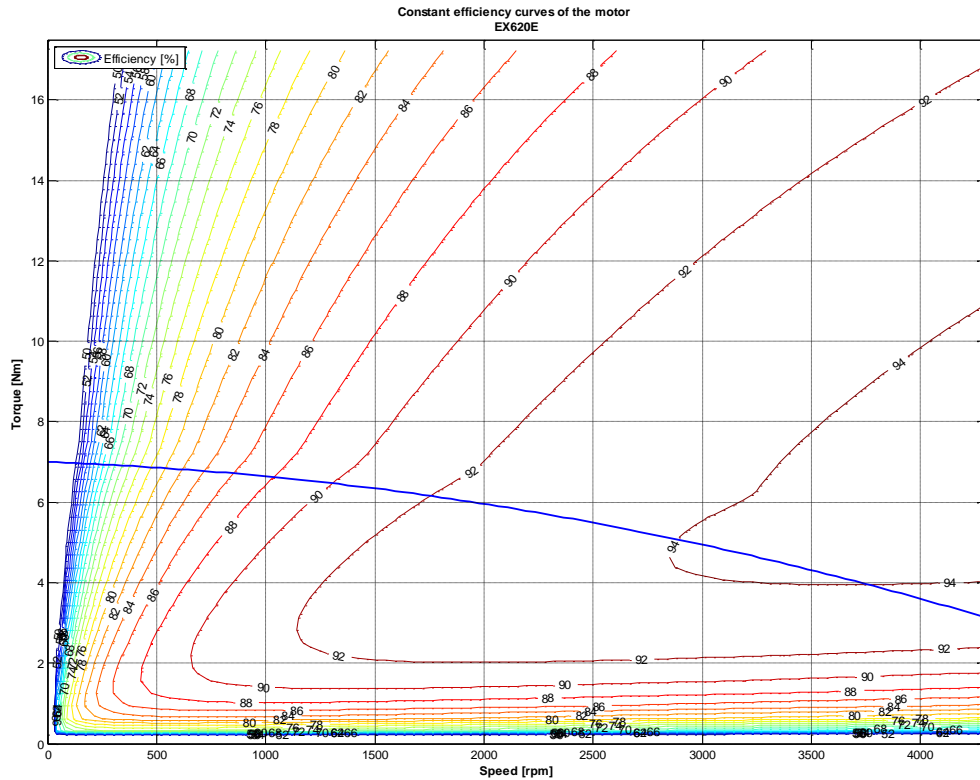

3.2.6.5. Series EX630E (EX630EAN)

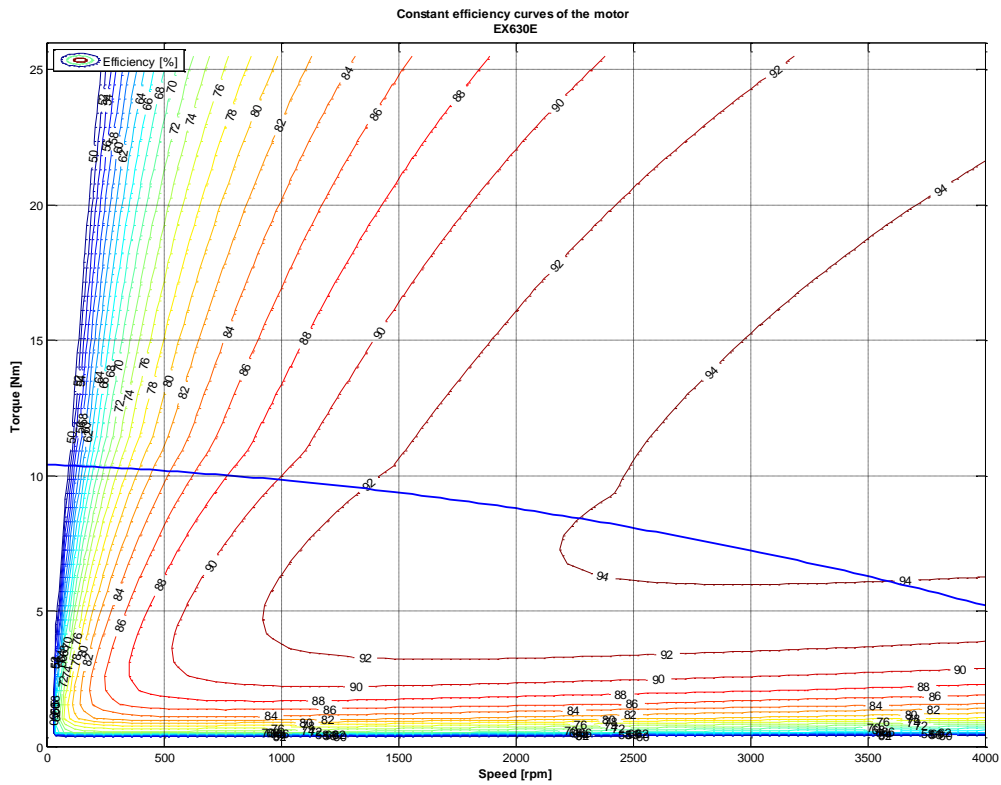

3.2.6.6. Series EX820E (EX820EAR)

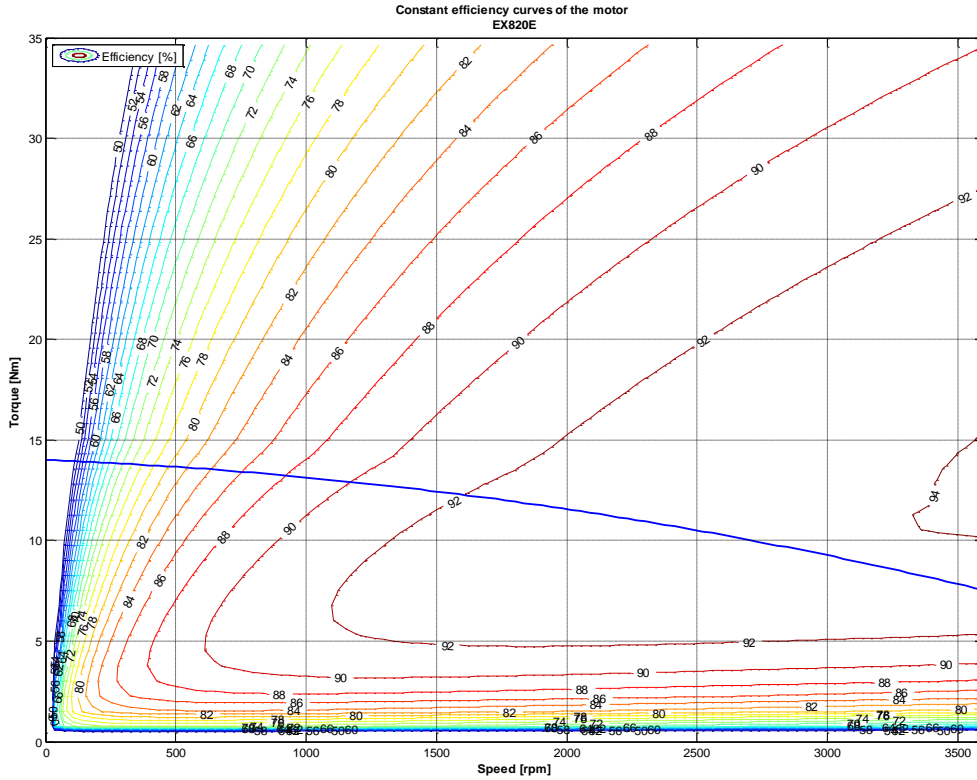

3.2.6.7. Series EX840E (EX840EAK)

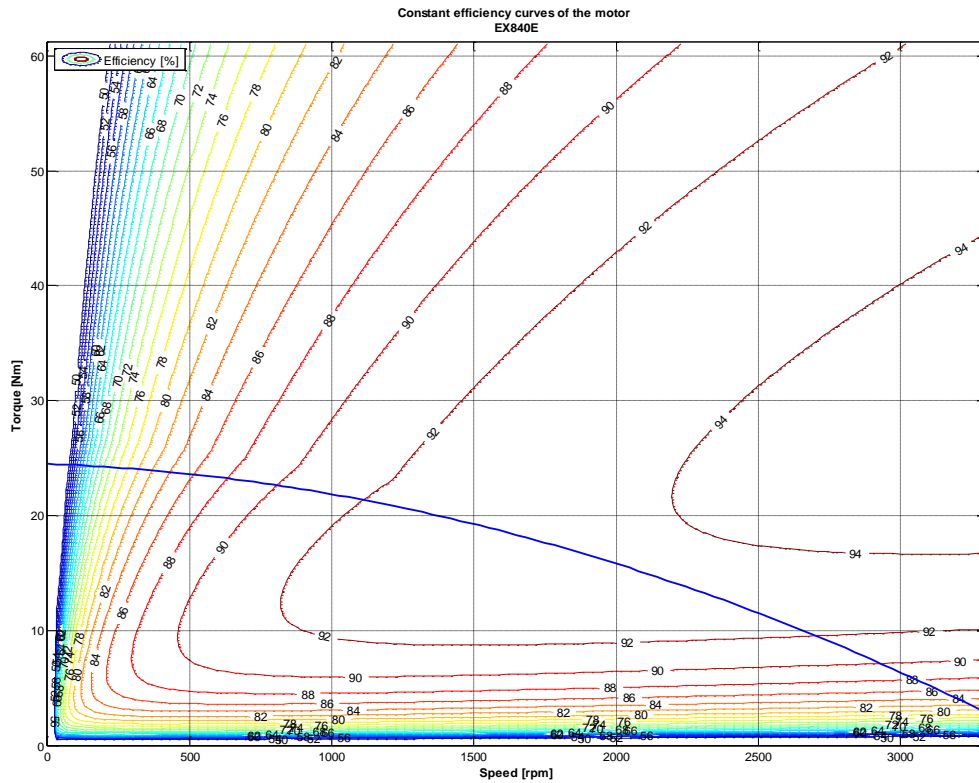



3.2.6.8. Series EX860E (EX860EAJ)

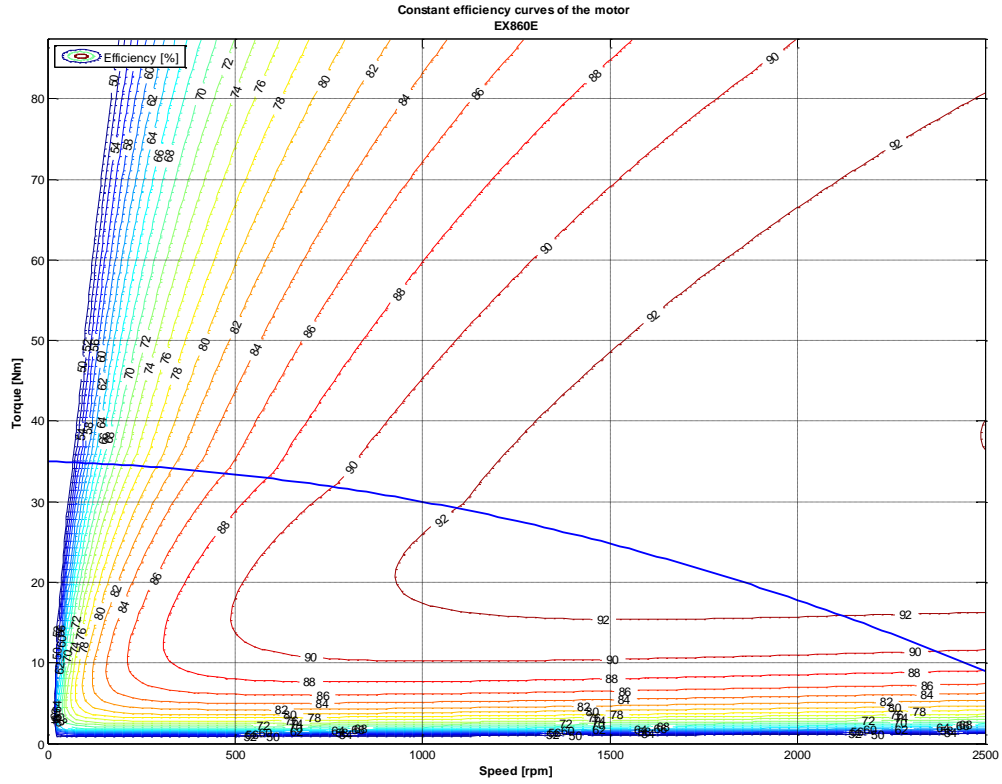



3.2.6.9. Series EX310U (EX310UAU)

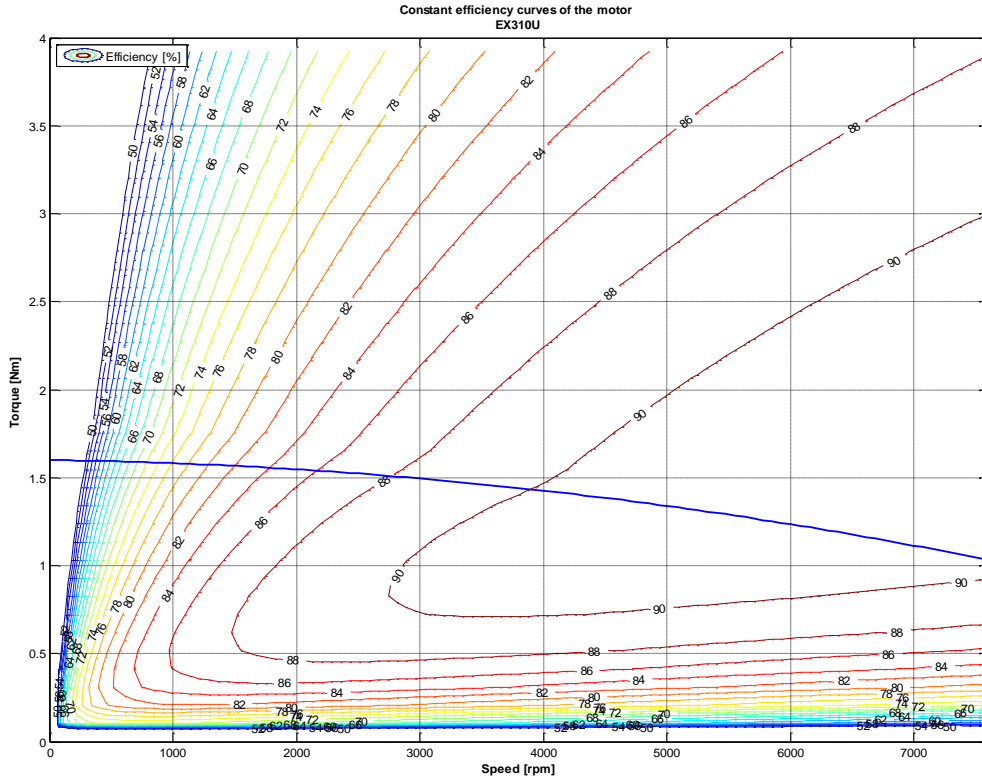

3.2.6.10. Series EX420U (EX420UAI)

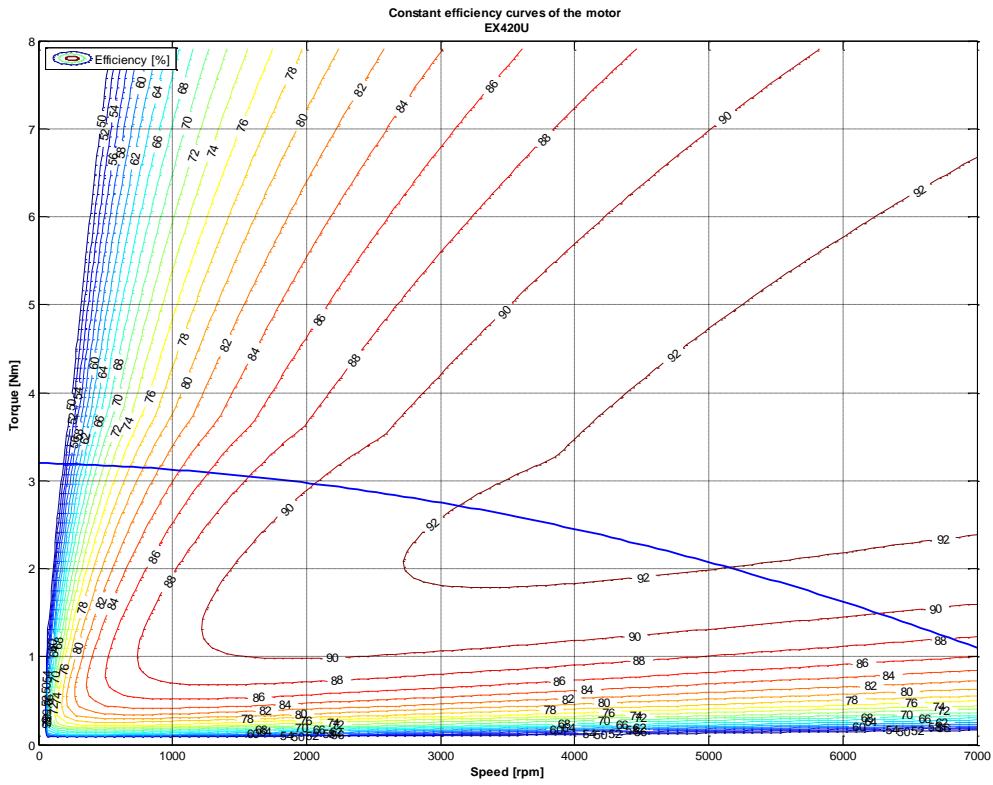

3.2.6.11. Series EX430U (EX430UAG)

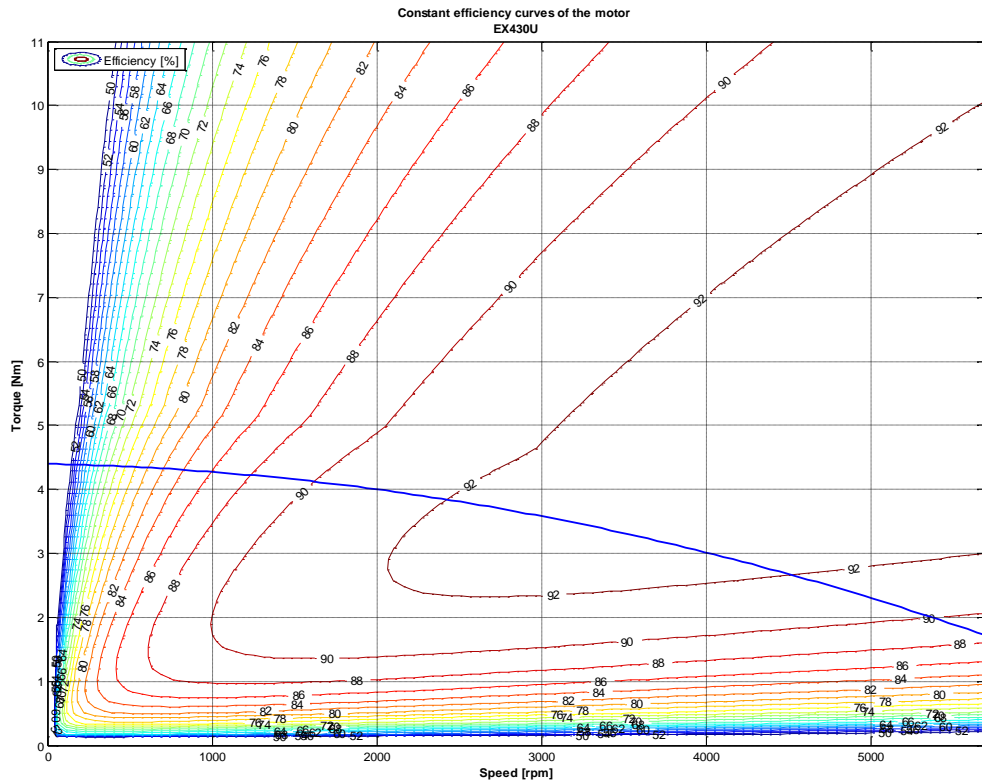

3.2.6.12. Series EX620U (EX620UAM)

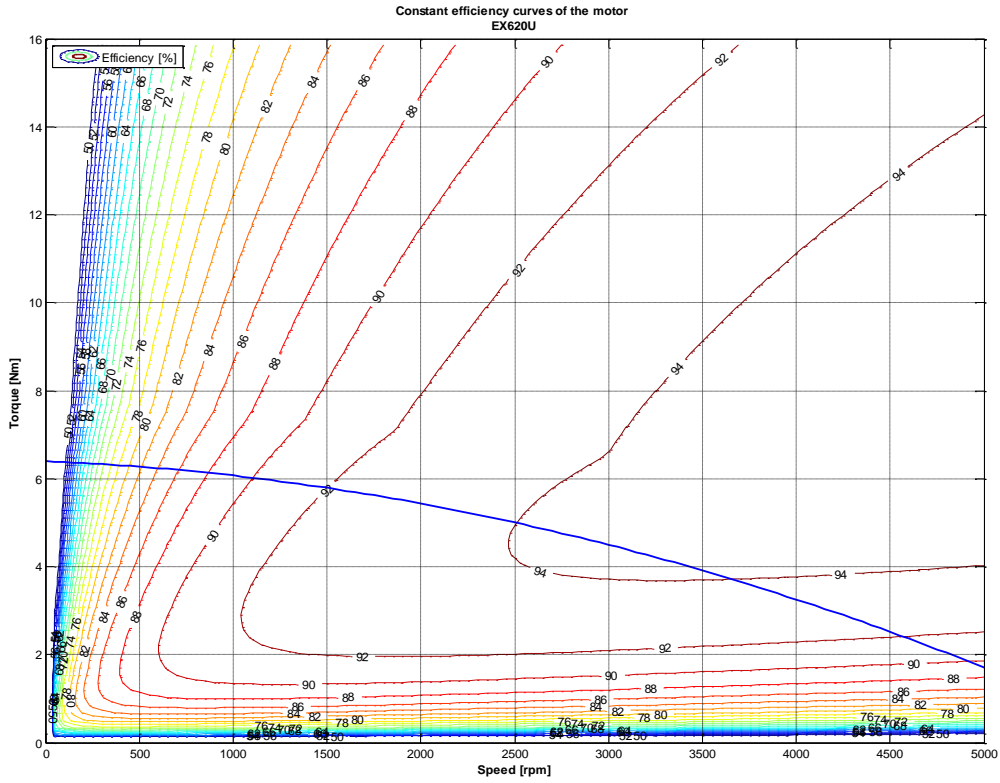

3.2.6.13. Series EX630U (EX630UAK)

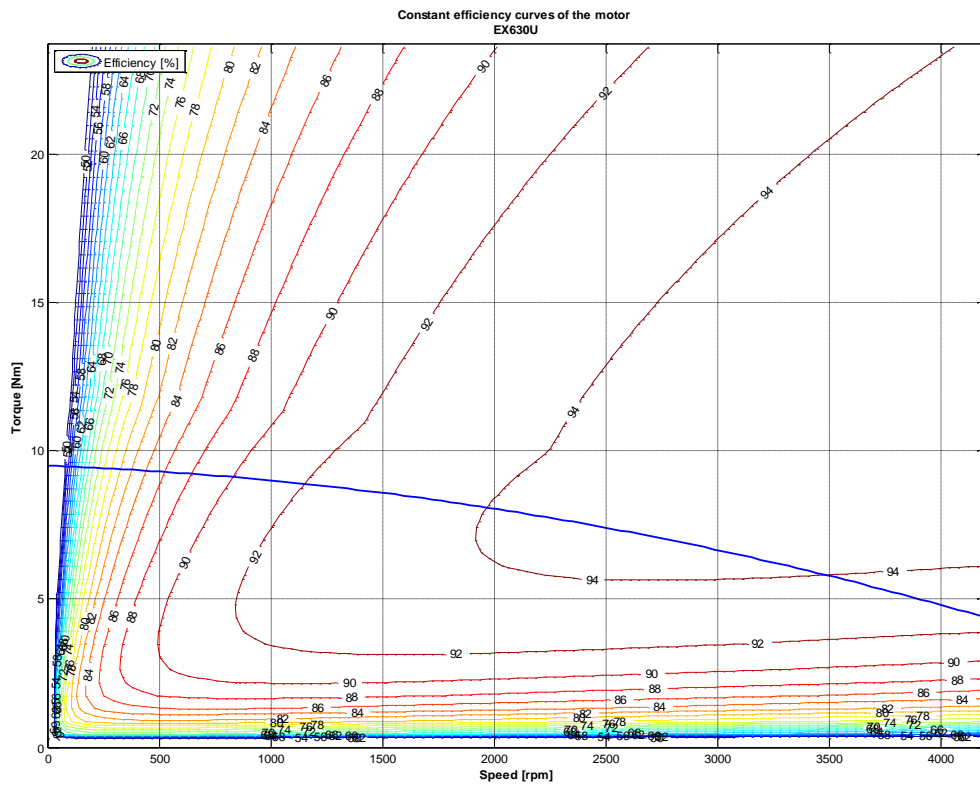

3.2.6.14. Series EX820U (EX820UAQ)

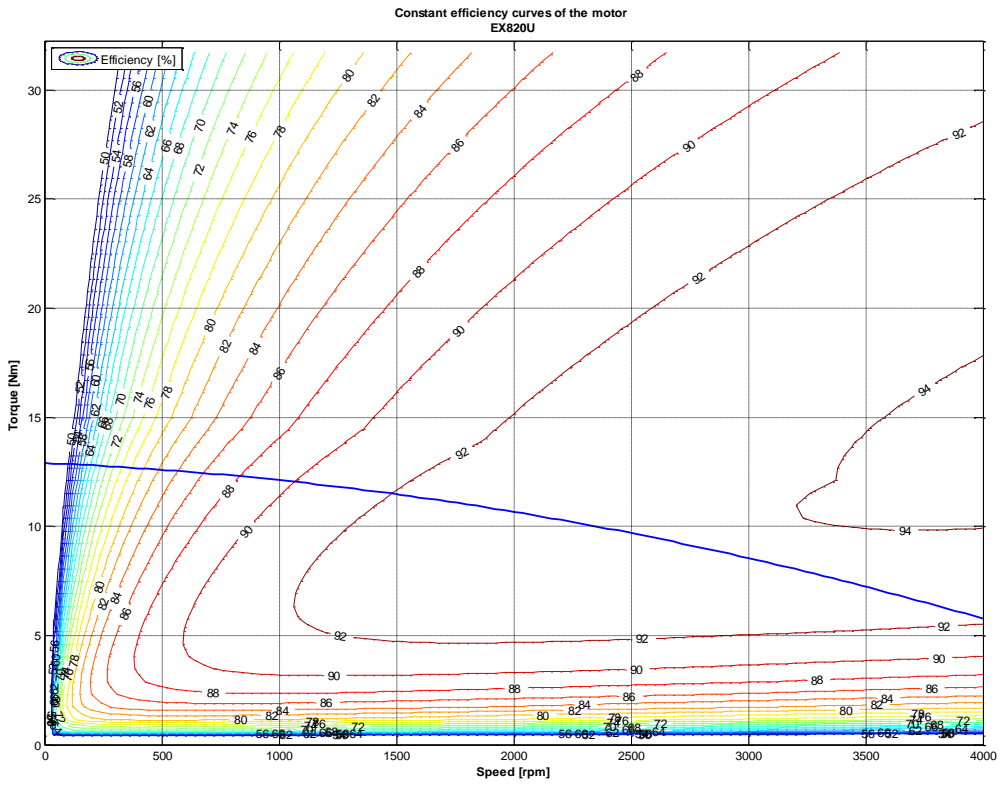

3.2.6.15. Series EX840U (EX840UAL)

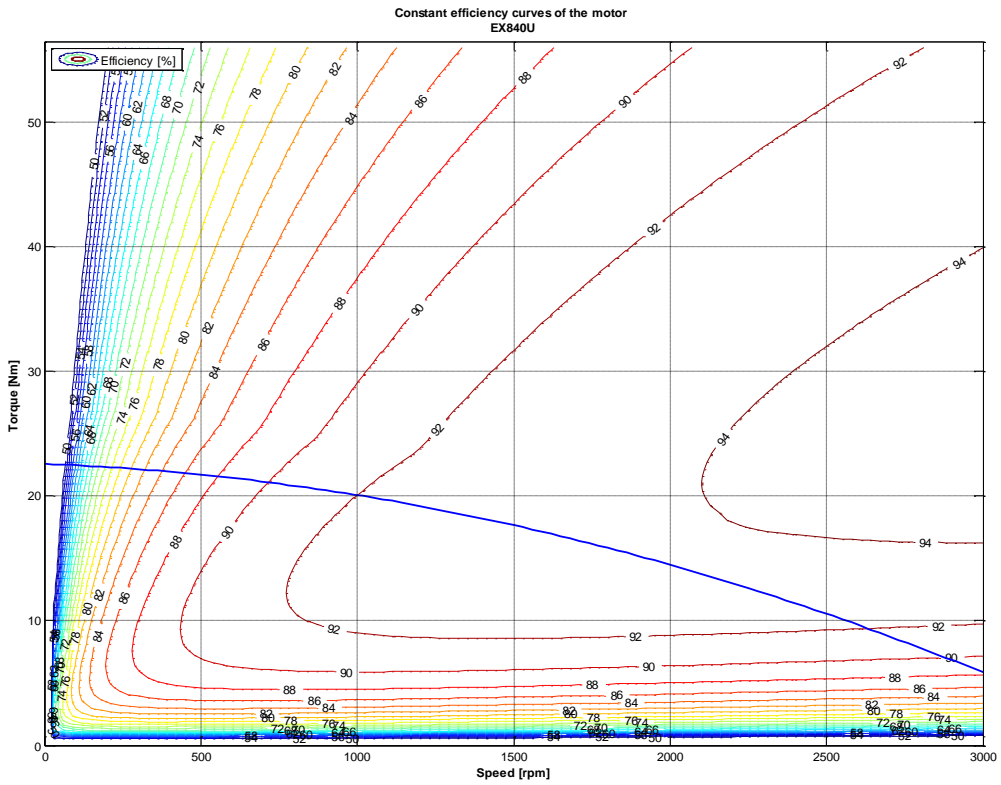

3.2.6.16. Series EX860U (EX860UAJ)

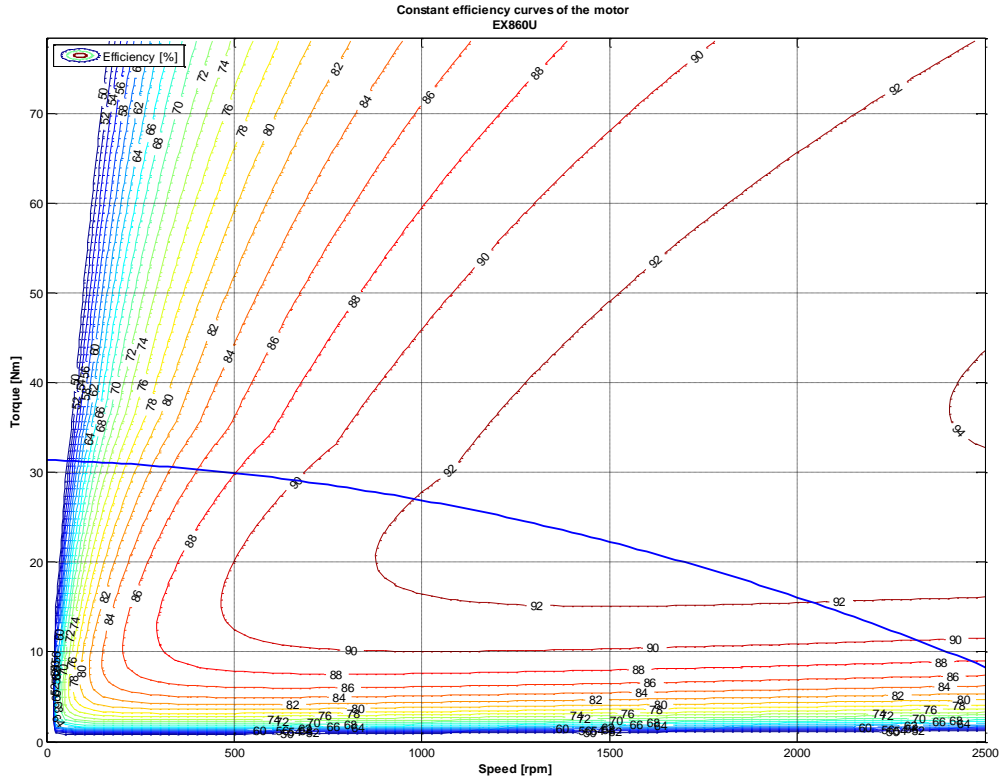

3.2.7. Electromagnetic losses



Caution: Following data result from our best estimations but are indicative. They can vary from one motor to another and with temperature. No responsibility will be accepted for direct or indirect losses or damages due to the use of these data.

(Following data are indicative, without lip seal, IP64 motor)

Type	Tf [Nm]	Kd [Nm/1000rpm]
EX310EAP	0.067	0.033
EX420EAP	0.090	0.114
EX430EAP	0.106	0.149
EX620EAR	0.106	0.196
EX630EAR	0.131	0.245
EX820EAR	0.160	0.300
EX840EAK	0.190	0.380
EX860EAJ	0.220	0.460

Torque losses (N.m) = Tf + Kd x speed(rpm)/1000

3.2.8. Time constants of the motor

3.2.8.1. Electric time constant:

$$\tau_{elec} = \frac{L_{ph_ph}}{R_{ph_ph}}$$

With following values given in the motor data sheet
 L_{ph_ph} inductance of the motor phase to phase [H],
 R_{ph_ph} resistance of the motor phase to phase at 25°C [Ohm].

Example:

Motor series EX620EAO

$L_{ph_ph} = 14 \text{ mH}$ or $14 \cdot 10^{-3} \text{ H}$

R_{ph_ph} at 25°C = 1.63 Ohm

→ $\sigma_{elec} = 14 \cdot 10^{-3} / 1.63 = 8.6 \text{ ms}$

An overall summary of motor time constants is given a little further.

3.2.8.2. Mechanical time constant:

$$\tau_{mech} = \frac{R_{ph_n} * J}{Kt * Ke_{ph_n}} = \frac{0.5 * R_{ph_ph} * J}{(3 * \frac{Ke_{ph_ph}}{\sqrt{3}}) * \frac{Ke_{ph_ph}}{\sqrt{3}}}$$

$$\tau_{mech} = \frac{0.5 * R_{ph_ph} * J}{(Ke_{ph_ph})^2}$$

With following values obtained from the motor data sheet:

R_{ph_ph} resistance of the motor phase to phase at 25°C [Ohm],

J inertia of the rotor [kgm²],

Ke_{ph_ph} back emf coefficient phase to phase [V_{rms}/rad/s].

The coefficient Ke_{ph_ph} in the formula above is given in [V_{rms}/rad/s]

To calculate this coefficient from the datasheet, use the following relation:

$$Ke_{ph_ph[V_{rms}/rad/s]} = \frac{Ke_{ph_ph[V_{rms}/1000rpm]}}{\frac{2 * \pi * 1000}{60}}$$

Example:

Motor series EX620EAO

R_{ph_ph} at 25°C = 1.63 Ohm

$J = 98 \cdot 10^{-5} \text{ kgm}^2$

$Ke_{ph_ph} [V_{rms}/1000rpm] = 81.7 [V_{rms}/1000rpm]$

→ $Ke_{ph_ph} [V_{rms}/rad/s] = 81.7 / (2 * \pi * 1000 / 60) = 0.7802 [V_{rms}/rad/s]$

→ $\sigma_{mech} = 0.5 * 1.63 * 98 \cdot 10^{-5} / (0.7802^2) = 1.3 \text{ ms}$

Remarks:

For a DC motor, the mechanical time constant σ_{mech} represents the duration needed to reach 63% of the final speed when applying a voltage step without any resistant torque. However this value makes sense only if the electric time constant σ_{elec} is much smaller than the mechanical time constant σ_{mech} (for the motor EX620EAO taken as illustration, it is not the case because we obtain $\sigma_{mech} < \sigma_{elec}$).

An overall summary of motor time constants is given a little further.

3.2.8.3. Thermal time constant of the copper:

$$\tau_{therm} = Rth * Cth_{copper}$$

$$Cth_{copper [J/^{\circ}K]} = Mass_{copper [Kg]} * 389_{[J/kg^{\circ}K]}$$

With:

- Rth** thermal resistance between copper and ambient temperature [$^{\circ}K/W$]
- Cth_{copper}** thermal capacity of the copper [$J/^{\circ}K$]
- Mass_{copper}** mass of the copper (winding) [kg]

Hereunder is given an overall summary of motor time constants:

Type	Electric time constant [ms]	Mechanical time constant [ms]	Thermal time constant of copper [s]
EX310	3.0	1.1	60.2
EX420	4.6	1.4	71.0
EX430	5.2	1.1	79.8
EX620	8.6	1.3	137
EX630	10.3	1.0	158
EX820	8.5	2.1	135
EX840	11.0	1.5	171
EX860	12.9	1.3	206

3.2.9. Speed ripple

The typical speed ripple for a EX motor with a resolver at 4000rpm is 3% peak to peak. This value is given as indicative data because depending on the settings of the drive (gains of both speed and current regulation loops, presence of filtering or not, load inertia, resistant torque and type of sensor in use), without external load (neither external inertia nor resistant torque).

3.2.10. Cogging torque

The typical cogging for a EX series below is the maximum value peak to peak in N.cm:

Motor	Cogging Maxi [N.cm]
EX310	2.5
EX420	4.4
EX430	5.7
EX620	5.3
EX630	6.8
EX820	9
EX840	16
EX860	20



3.2.11. Rated data according to rated voltage variation

The nominal characteristics and especially the rated speed, maximal speed, rated power, rated torque, depend on the nominal voltage supplying the motor considered as the rated voltage. The rated data mentioned in the data sheet are given for each association of motor and drive. Therefore, if the supply voltage changes, the rated values will also change. As long as the variation of the rated voltage remains limited, for instance to $\pm 10\%$ of the nominal value, it is possible to correctly evaluate the new rated values as illustrated below.

Example:

Extract of Ex630EAI datasheet

BRUSHLESS MOTOR		
EX630EAI		
ELECTRONIC DRIVE		
DRIVE 10/36 Arms 230 Vac		

No UL certification

P _n	Rated power **	2.27	<i>kW</i>	Cooling type : Natural Air cooling Flange 400*400*12mm(ALU)
M _n	Rated torque **	7.24	<i>Nm</i>	
N _n	Rated speed	3000	<i>rpm</i>	
I _n	Rated current	6.75	<i>A_{rms}</i>	
U _n	Rated voltage	205	<i>V_{rms}</i>	
UR	Voltage of the mains	230	<i>V_{rms}</i>	
U	DC voltage supply when motor is loaded	310	<i>V</i>	
M _o	Low speed torque **	10.4	<i>N.m</i>	Environment : Ambient temperature : 40°C MAX Altitude : < 1000 m Thermal class : F <small>(according to IEC 60034-1)</small>
I _o	Permanent current at low speed	9.28	<i>A_{rms}</i>	
M _p	Max. torque **	25.9	<i>Nm</i>	
I _p	Max. current	23.2	<i>A_{rms}</i>	
N _p	Max. speed	3000	<i>rpm</i>	
J	Rotor inertia	0.0015	<i>kg.m²</i>	Number of poles : 10
K _e	Back emf constant at 1000 rpm (25°C)*	68.2	<i>V_{rms}</i>	Efficiency : at rated torque : 94.4 % at 75% of rated torque : 93.9 %
K _t	Torque sensitivity (25°C) *	1.12	<i>Nm/A_{rms}</i>	
R _b	Winding resistance(25°C) *	0.595	<i>Ω</i>	
L	Winding inductance *	6.06	<i>mH</i>	

All data are given in typical values under standard conditions

* Phase to Phase

** General tolerances $\pm 7.5\%$, rotor at 25°C

If we suppose that the rated voltage $U_n=400 V_{rms}$ decreases of **10%** ; this means that the new rated voltage becomes $U_{n2}=360 V_{rms}$.

Rated speed:

The former rated speed $N_n=3000 rpm$ obtained with a rated voltage $U_n=400 V_{rms}$ and an efficiency $\eta=92\%$ leads to the new rated speed N_{n2} given as follows:

$$N_{n2} = N_n * \frac{\frac{U_{n2}}{U_n} - 1 + \eta}{\eta}$$

$$N_{n2} = 3000 * \frac{\frac{360}{400} - 1 + 0.92}{0.92} = 2674rpm$$

Maximum speed:

The former maximum speed $N_{\max} = 3000$ rpm obtained with $U_n = 400$ V_{rms} and a speed $N_n = 3000$ rpm leads to the new maximum speed $N_{\max 2}$ given as follows:

$$N_{\max 2} = N_{\max} * \frac{N_{n2}}{N_n} \qquad N_{\max 2} = 3000 * \frac{2674}{3000} = 2674 \text{rpm}$$

N.B.

If the rated voltage increases ($U_{n2} > U_n$), the new rated speed N_{n2} and the new maximum speed $N_{\max 2}$ will be greater than the former ones N_n and N_{\max} . Moreover you will have to check that the drive still shows able to deal with the new maximum electric frequency.

	<p><u>Warning:</u> If the main supply decreases, you must reduce the maximum speed accordingly in order to do not damage the motor. In case of doubt, consult us.</p>
---	---

Rated power:

The former rated power $P_n = 2270$ W obtained with $U_n = 400$ V_{rms} leads to the new rated power P_{n2} given as follows:

$$P_{n2} = P_n * \frac{U_{n2}}{U_n} \qquad P_{n2} = 2270 * \frac{360}{400} = 2043 \text{W}$$

Rated torque:

The former rated torque $M_n = 7.24$ Nm obtained with $U_n = 400$ V_{rms} leads to the new rated torque M_{n2} given as follows:

$$M_{n2} = \frac{P_{n2}}{2 * \pi * N_{n2} / 60} \qquad M_{n2} = \frac{2043}{2 * \pi * 2674 / 60} = 7.3 \text{Nm}$$

3.2.12. Voltage withstand characteristics of EX series

The motors fed by converters are subject to higher stresses than in case of sinusoidal power supply. The combination of fast switching inverters with cables will cause overvoltage due to the transmission line effects. The peak voltage is determined by the voltage supply, the length of the cables and the voltage rise time. As an example, with a rise time of 200 ns and a 30 m (100 ft) cable, the voltage at the motor terminals is twice the inverter voltage. The insulation system of the servomotors EX is designed to withstand high repetitive pulse voltages and largely exceeds the recommendations of the IEC/TS 60034-25 ed 2.0 2007-03-12 for motors without filters up to 500V AC (See figure 1).

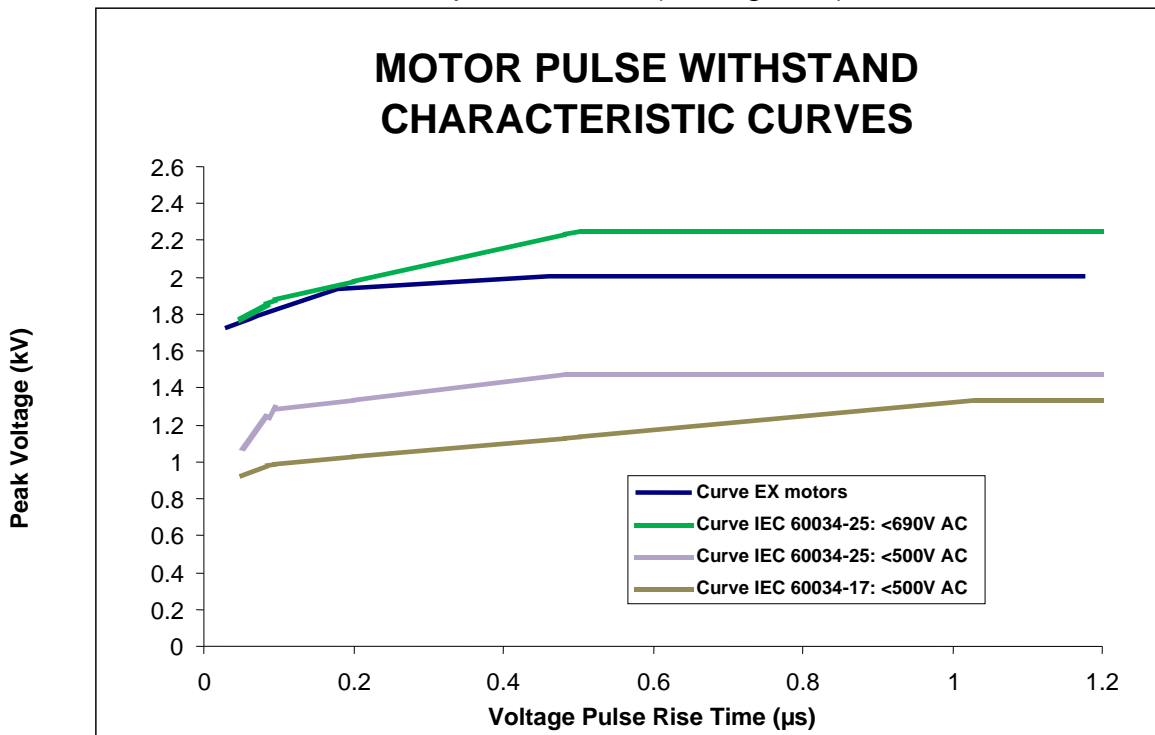

Figure 1: Minimum Voltage withstands characteristics for motors insulations according to IEC standards. At the top are the typical capabilities for the EX motors.

Note: The pulse rise times are defined in accordance with the IEC/TS 60034-17 ed4.0 2006-05-09.

The EX motors can be used with a supply voltage up to 480 V under the following conditions:

- The pulse rise times must be longer than 50 ns.
- The repetitive pulse voltages must not exceed the values given in figure 1, “Curve EX motors” in dark blue.

3.2.13. Voltage and current during the operating

The EX motors can carry ATEX, IECEx, CCC and UL certification and due to this certificate, they are subjected to strict rules regarding their use. One of such rules is the use of a servoamplifier that meets specific characteristics.

EX310 ATEX, IECEx, CCC :

Voltage of the associated speed drive	24V direct current	48V direct current	230V single / three phase	400V three phase
Power supply direct current voltage (V)	24 ±10%	48 ±10%	310 ±10%	550 ±10%
Motor electrical frequency (Hz)	0 to 700	0 to 700	0 to 700	0 to 700
Steady peak current in a phase (Â/Arms)	Max. 17/12	Max. 17/12	Max. 7.5/5.3	Max. 4/2.8
Maximum peak current in a phase (Â/Arms)	Max. 34/24	Max. 34/24	Max. 15/10.6	Max. 8/5.6
Maximum steady motor power (W)	Max. 250	Max. 500	Max. 1900	Max. 1800

EX4 ATEX, IECEx, CCC :

Voltage of the associated speed drive	24V direct current	48V direct current	230V single / three phase	400V three phase
Power supply direct current voltage (V)	24 ±10%	48 ±10%	310 ±10%	550 ±10%
Motor electrical frequency (Hz)	0 to 600	0 to 600	0 to 600	0 to 600
Steady peak current in a phase (Â/Arms)	Max. 17/12	Max. 17/12	Max. 14/9.9	Max. 8/5.6
Maximum peak current in a phase (Â/Arms)	Max. 34/24	Max. 34/24	Max. 28/19.8	Max. 16/11.3
Maximum steady motor power (W)	Max. 200	Max. 400	Max. 3400	Max. 3400

EX6 ATEX, IECEx, CCC :

Voltage of the associated speed drive	230V single / three phase	400V three phase
Power supply direct current voltage (V)	310 ±10%	550 ±10%
Motor electrical frequency (Hz)	0 to 500	0 to 500
Steady peak current in a phase (Â/Arms)	Max. 25/17.7	Max. 16/11.3
Maximum peak current in a phase (Â/Arms)	Max. 50/35.3	Max. 32/22.6
Maximum steady motor power (W)	Max. 6000	Max. 6000

EX8 ATEX, IECEx, CCC :

Voltage of the associated speed drive	230V single / three phase	400V three phase
Power supply direct current voltage (V)	310 ±10%	550 ±10%
Motor electrical frequency (Hz)	0 to 500	0 to 500
Steady peak current in a phase (Â/Arms)	Max 100/70.7	Max 50/35.3
Maximum peak current in a phase (Â/Arms)	Max 200/141.4	Max 100/70.7
Maximum steady motor power (W)	Max 10 000	Max 10 000

EX310 UL :

Voltage of the associated speed drive	230V single / three phases	400-480V three phases
Nominal Power supply direct current voltage(v)	310 ±10%	550-660 ±10%
Motor electrical frequency (Hz)	0 to 650	0 to 650
Steady peak current in a phase (Â/Arms)	Max. 7.5/5.3	Max. 4/2.8
Maximum peak current in a phase (Â/Arms)	Max. 15/10.6	Max. 8/5.6
Maximum steady motor power (W)	Max. 1900	Max. 1800

EX4 UL :

Voltage of the associated speed drive	230V single / three phases	400-480V three phases
Nominal Power supply direct current voltage (V)	310 ±10%	550-660 ±10%
Motor electrical frequency (Hz)	0 to 650	0 to 650
Steady peak current in a phase (Â/Arms)	Max. 14/9.9	Max. 8/5.6
Maximum peak current in a phase (Â/Arms)	Max. 28/19.8	Max. 16/11.3
Maximum steady motor power (W)	Max. 3400	Max. 3400

EX6 UL :

Voltage of the associated speed drive	230V single / three phases	400- 480V three phases
Nominal Power supply direct current voltage (V)	310 ±10%	550-660 ±10%
Motor electrical frequency (Hz)	0 to 650	0 to 650
Steady peak current in a phase (Â)	Max. 25	Max. 16
Maximum peak current in a phase (Â)	Max. 50	Max. 32
Maximum steady motor power (W)	Max. 6000	Max. 6000

EX8 UL :

Voltage of the associated speed drive	230V single / three phases	400-480V three phases
Nominal Power supply direct current voltage (V)	310 ±10%	550-660 ±10%
Motor electrical frequency (Hz)	0 to 500	0 to 500
Steady peak current in a phase (Â)	Max 100	Max 50
Maximum peak current in a phase (Â)	Max 200	Max 100
Maximum steady motor power (W)	Max 10 000	Max 10 000



Warning : EX motors must be connected in accordance with the diagrams given in chapter §4.3.3

3.3. Dimension drawings

3.3.1. EX310E

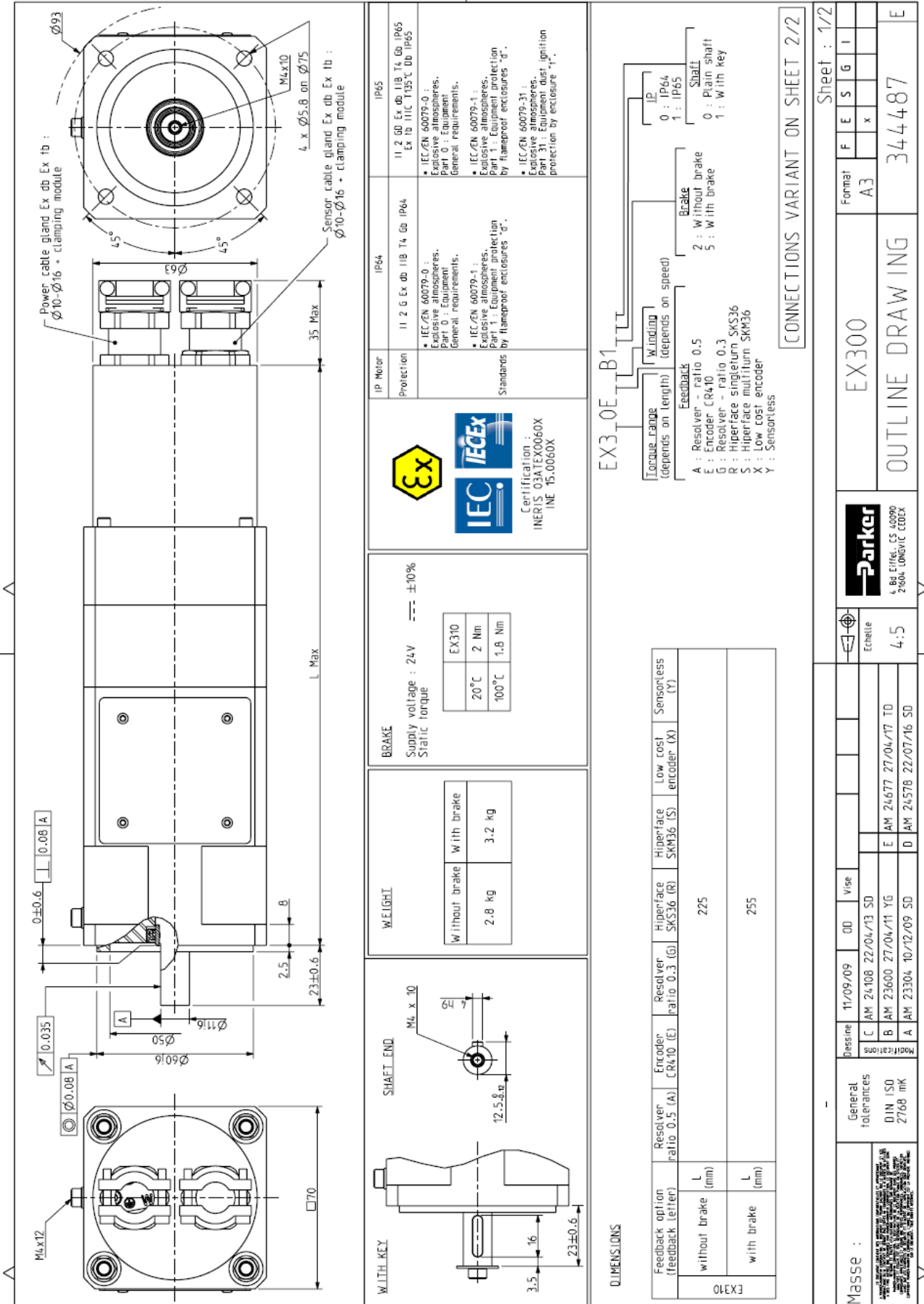

3.3.2. EX420E EX430E

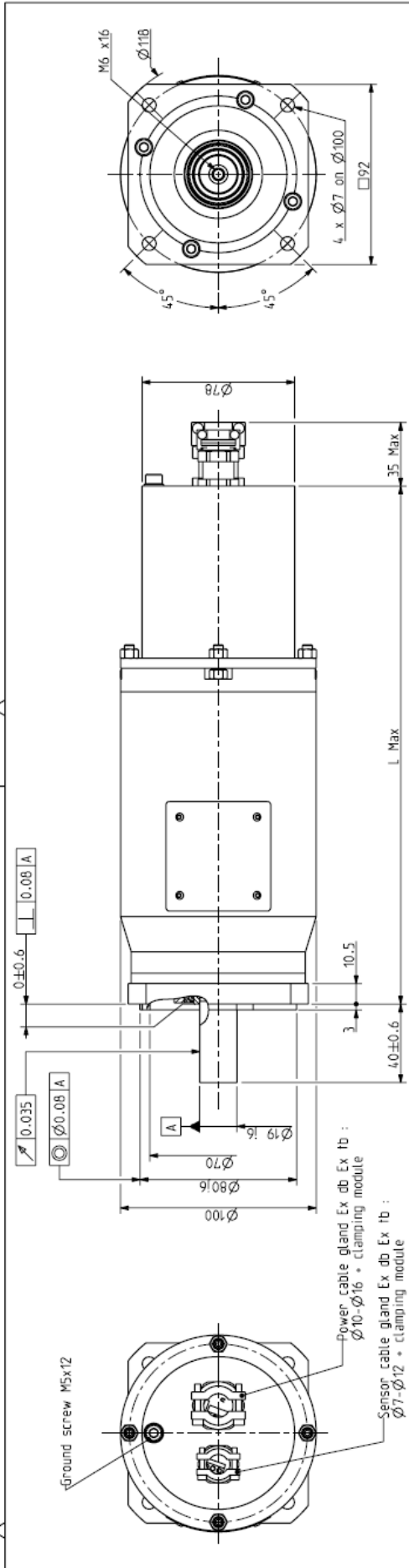

WELIGHT

Motor	W without brake	W with brake
EX420	7 Kg	8 Kg
EX430	8 Kg	9 Kg

BRAKE

Supply voltage : 24V
Static torque

EX420	EX430
5.5 N.m	5.5 N.m
4. N.m	4. N.m

SHAFT END

IP MOTOR

Protection: IP64

IP65

11 2 G Ex db 118 14 Gb IP64

11 2 Gb Ex db 118 14 Gb IP65

Ex tb 111C 135°C Db IP65

• IEC/EN 60079-0 : Explosive atmospheres. Part 0 : Equipment. General requirements.

• IEC/EN 60079-1 : Explosive atmospheres. Part 1 : Protection by flameproof enclosures "d".

• IEC/EN 60079-31 : Explosive atmospheres. Part 31 : Equipment dust ignition protection by enclosure "t".

EX

IEC

IECEx

Certification : INERIS 04-ATEX0097X
INE 15.0060X

EX4 E B1

Torque range (depends on length) | Winding | Brake | Shaft

(depends on length) | (depends on speed) | 0 : IP64 | 1 : IP65

Feedback

A : Resolver - ratio 0.5
G : Resolver - ratio 0.3
R : Hiperface singletium SKS36
S : Hiperface multium SKM36
T : Hiperface singletium SR550
U : Hiperface multium SRM50
X : Low cost encoder
Y : Sensorless

2 : W without brake
5 : W with brake

0 : Plain shaft
1 : With key

DIMENSIONS

Feedback options (feedback letter)	Resolver ratio 0.5 (A)	Resolver ratio 0.3 (G)	Encoder (X)	Low cost encoder (X)	Sensors (Y)	Hiperface SKS36 (R)	Hiperface SM36 (S)	Hiperface SR550 (T)	Hiperface SRM50 (U)
Without brake	265	290	290	315		285	310	330	305
With brake						310	330	330	330
Without brake						335	335	355	
With brake									

CONNECTIONS VARIANTS ON SHEET 2/2

Sheet : 1/2

Parker

EX400

OUTLINE DRAWING

344619

Format A3

F E S G I

x

1:2

Echelle

General tolerances
DIN ISO 2768 mK

Design 29/07/09 SD Vise

Modifications
C AM 24229 03/12/13 AH
B AM 24108 22/04/13 SD
A AM 23304 10/12/09 SD

AM 24677 27/04/17 TD
D AM 24578 22/07/16 SD

4 Bd Etrel, CS 40090
2806, LONGVIC CODEX

3.3.3. EX620E EX630E

IP Motor Protection II 2 G Ex db IIB T4 Gb IP64 <ul style="list-style-type: none"> • IEC/EN 60079-0 : Explosive atmospheres. Part 0 : Equipment. General requirements. • IEC/EN 60079-1 : Explosive atmospheres. Part 1 : Equipment protection by flameproof enclosures "d". 	IP64 II 2 G Ex db IIB T4 Gb IP64 <ul style="list-style-type: none"> • IEC/EN 60079-0 : Explosive atmospheres. Part 0 : Equipment. General requirements. • IEC/EN 60079-1 : Explosive atmospheres. Part 1 : Equipment protection by flameproof enclosures "d". 	IP65 II 2 Gb Ex db IIB T4 Gb IP65 Ex tb IIIC T135°C Db IP65 <ul style="list-style-type: none"> • IEC/EN 60079-0 : Explosive atmospheres. Part 0 : Equipment. General requirements. • IEC/EN 60079-1 : Explosive atmospheres. Part 1 : Equipment protection by flameproof enclosures "d". • IEC/EN 60079-31 : Explosive atmospheres. Part 31 : Equipment protection by enclosure "1". 	

W. WITH KEY

SHAFT END

W. WITHOUT KEY

SHAFT END

WEIGHT

Motor	Without brake	With brake
EX620	10 Kg	11 Kg
EX630	12.5 Kg	13.5 Kg

BRAKE

Supply voltage : 24V --- ±10%

Static torque

Temperature	EX620	EX630
20 °C	12 N.m	12 N.m
100 °C	8 N.m	8 N.m

Dimensions

EX6 E B1

Torque range (depends on length) Winding (depends on speed) IP

Feedbacks Brake

A : Resolver - ratio 0.5
 G : Resolver - ratio 0.3
 S : Hiperrace multiturm SKS36
 T : Hiperrace multiturm SKS36 SD
 U : Hiperrace multiturm SKS50
 V : Hiperrace multiturm EAG 1125
 W : Encoder multiturm EAG 1125
 X : low cost encoder
 Y : Sensorless

CONNECTIONS VARIANTS ON SHEET 2/2

Format	A3	F	E	S	G	I
		x				

General tolerances

DIN ISO 2768 mK

Design

Design	07/10/09	SD	Vise
C	AM 24229	03/12/13	AH
B	AM 24108	22/04/13	SD
A	AM 23304	10/12/09	SD

Masses

E	AM 24677	27/04/17	TD
D	AM 24578	22/07/16	SD

Scale

Echelle 1:2

Sheet

Sheet : 1/2

Product Name

EX600

Product Name

OUTLINE DRAWING

Product Name

344550

Product Name

E

3.3.4. EX820E EX840E EX860E

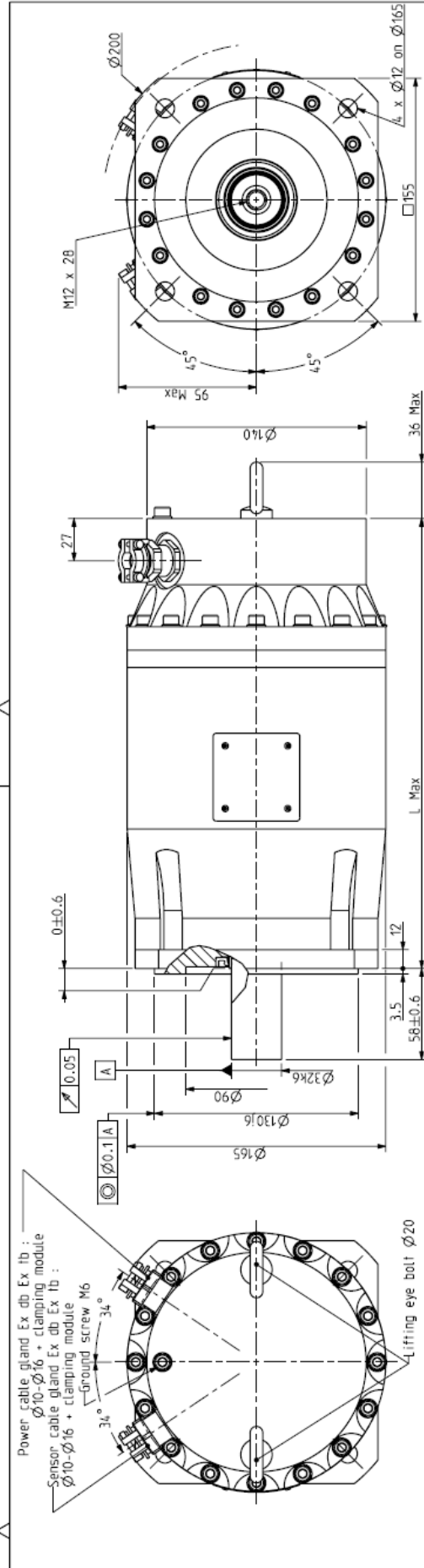

IEC IECEx

Certification :
INERIS 05ATEX0061X
INE 15.0060X

IP MOTOR

Protection II 2 G Ex db IIB T4 Gb IP64

IP65 II 2 Gb Ex db IIB T4 Gb IP65
Ex Ib IIC T135°C Db IP65

- IEC/EN 60079-0 : Explosive atmospheres. Part 0 : Equipment. General requirements.
- IEC/EN 60079-1 : Explosive atmospheres. Part 1 : Equipment protection by flameproof enclosures "d".
- IEC/EN 60079-31 : Explosive atmospheres. Part 31 : Equipment dust ignition protection by enclosure "t".

BRAKE

Supply voltage : 24V ±10%

	EX820	EX840	EX860
Static torque	36 Nm	36 Nm	36 Nm
20°C	32 Nm	32 Nm	32 Nm
100°C	32 Nm	32 Nm	32 Nm

W.EIGHT

Motion	EX820	EX840	EX860
without brake	22 kg	28 kg	38 kg
with brake	25 kg	31 kg	41 kg

EX820E B1

Torque range (depends on length)

Feedback

- A : Resolver - ratio 0.5
- B : Resolver - ratio 0.1
- S : HiFace singulturn SKS36
- T : HiFace multiturn SSS50
- U : HiFace singulturn SPMS0
- V : HiFace multiturn ECN 1113
- W : Endat multiturn EDN 1125
- X : Low cost encoder
- Y : Sensorless

Brake

- 2 : Without brake
- 5 : With brake

IP

- 0 : IP64
- 1 : IP65

Shaft

- 0 : Plain shaft
- 1 : With key

DIMENSIONS		Feedback option (feedback letter)	Resolver ratio 0.5 (A)	Low cost encoder (X)	Sensorless (Y)	HiFace SKS36 (R)	HiFace SKS36 (S)	HiFace SSS50 (T)	HiFace SPMS0 (U)	Endat ECN 1113 (V)	Endat EDN 1125 (W)
EX820	without brake	L	290	290	310	310	310	325	325	325	325
	with brake	L	325	325	345	345	345	360	360	360	360
EX840	without brake	L	350	350	370	370	370	385	385	385	385
	with brake	L	385	385	405	405	405	420	420	420	420
EX860	without brake	L	410	410	430	430	430	445	445	445	445
	with brake	L	445	445	465	465	465	480	480	480	480

CONNECTIONS VARIANT ON SHEET 2/2

Sheet : 1/2

EX800

OUTLINE DRAWING

344664

Format A3

F E S G I

Scale 2:5

Design 14/09/09

Drawn C AM 24.607 26/06/16 SD

Checked B AM 24.108 22/04/13 SD

Validated A AM 23.304 10/12/09 SD

General tolerances DIN ISO 2768 mK

Parker
4, Bd Eiffel, CS 40090
25004 LONGVIC CODEX

3.3.5. EX310...C (CCC)

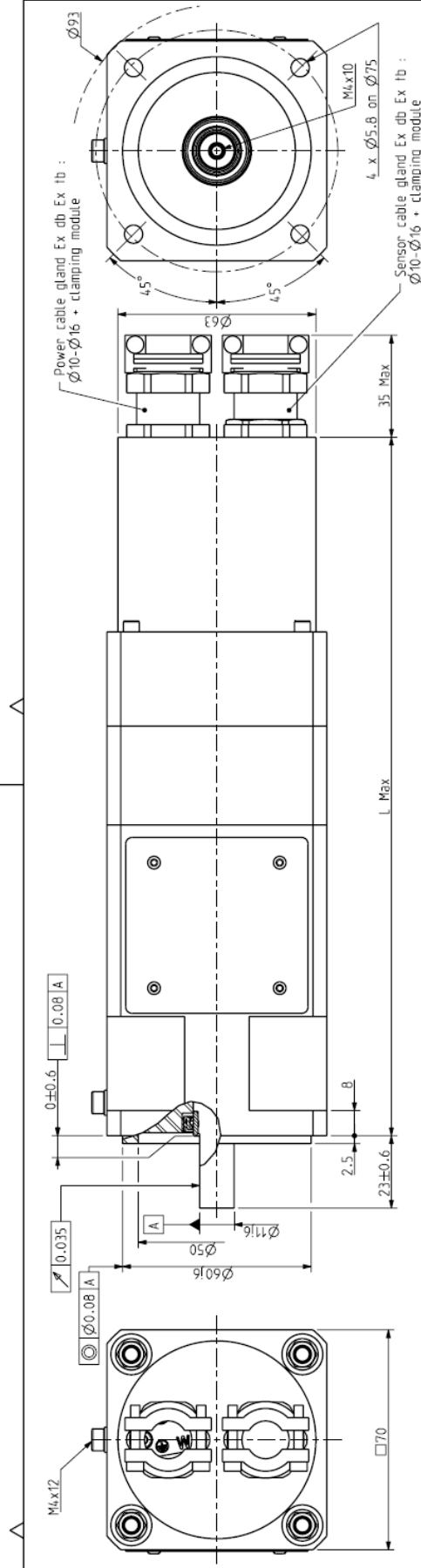

 Certification : CNEX 2021312301002772	IP Motor Protection • GB3836.1-2010 & GB3836.2-20210	IP64 Ex d IIB T4 Gb	IP65 Ex d IIB T4 Gb Ex ID A21 IP65 T35°C									
	BRAKE Supply voltage : 24V Static torque $\pm 10\%$ <table border="1"> <tr> <td>EX310</td> <td>2 Nm</td> </tr> <tr> <td>20°C</td> <td>100°C</td> </tr> <tr> <td>100°C</td> <td>1.8 Nm</td> </tr> </table>	EX310	2 Nm	20°C	100°C	100°C	1.8 Nm	WEIGHT <table border="1"> <tr> <td>without brake</td> <td>2.8 kg</td> </tr> <tr> <td>with brake</td> <td>3.2 kg</td> </tr> </table>	without brake	2.8 kg	with brake	3.2 kg
EX310	2 Nm											
20°C	100°C											
100°C	1.8 Nm											
without brake	2.8 kg											
with brake	3.2 kg											
WITH KEY 	WITHOUT KEY 	Winding (depends on length)	Brake 2 : without brake 5 : with brake									

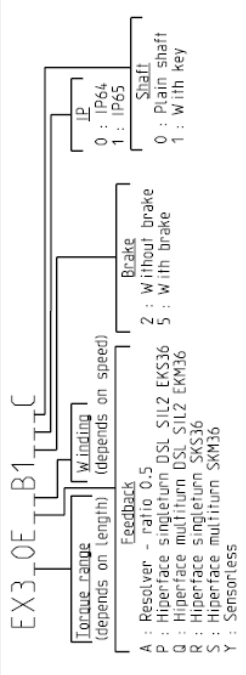

DIMENSIONS

Feedback option (feedback Letter)	Resolver (ratio 0.5 (A))	Hiperface (EKM36 (Q))	Hiperface (EKM36 (P))	Hiperface (EKM36 (R))	Hiperface (SKM36 (S))	Sensorless (Y)
without brake				225		
with brake				255		

CONNECTIONS VARIANT ON SHEET 2/2

Sheet : 1/2

EX300

OUTLINE DRAWING

345411

Format A3

Scale 4:5

Enchelle

General tolerances
 DIN ISO 2768 mK

19/03/2021

1000319
 1000319

1000319

3.3.6. EX420...C; EX430...C (CCC)

	IP64 Ex d IIB T4 Gb	IP65 Ex d IIB T4 Gb Ex ID A21 IP65 T135°C			
	Protection • GB3836.1-2010 & GB3836.2-2010		Standards • GB12476.1-2013 & GB12476.5-2013		
Certification : CNEX 2021312301002773					

WEIGHT	
Motor w/ithout brake w/ith brake	EX420 EX430
7 Kg 8 Kg	5.5 N.m 5.5 N.m
8 Kg 9 Kg	4 N.m 4 N.m

BRAKE	
Supply voltage : 24V	±10%
Static torque	
20°C	4 N.m
100°C	4 N.m

DIMENSIONS

Feedback options (feedback letter)	Resolver ratio 0.5 (A)	Sensorless (T)	Hiperface SK536 (R)	Hiperface SK956 (S)	Hiperface EK536 (P)	Hiperface EM956 (D)	Hiperface SR550 (T)	Hiperface SR950 (U)
w/ithout brake L (mm)	265	285	310	330	305	330	330	355
w/ith brake L (mm)	290	310	330	355	330	330	355	355
w/ithout brake L (mm)	290	310	330	355	330	330	355	355
w/ith brake L (mm)	315	335	355	380	355	355	355	355

EX4 E B1 C

Torque range (depends on length)

Winding (depends on speed)

Feedback

IP

Brake

Shaft

A : Resolver - ratio 0.5
 P : Hiperface singleturn DSL S1L2 EK536
 Q : Hiperface multiturn DSL S1L2 EK936
 R : Hiperface singleturn SK536
 S : Hiperface multiturn SK936
 T : Hiperface singleturn SR550
 U : Hiperface multiturn SR950
 Y : Sensorless

0 : IP64
 1 : IP65
 0 : Plain shaft
 1 : With key

CONNECTIONS VARIANTS ON SHEET 2/2

Masse :

General tolerances
DIN ISO 2768 mK

Signature
Sebastien Duband
Date: 2021.03.19
160380-01007

Dessine: 19/03/2021

PF

Vise

Format: A3

Sheet : 1/2

EX400

OUTLINE DRAWING

345412

3.3.7. EX620...C; EX630...C (CCC)

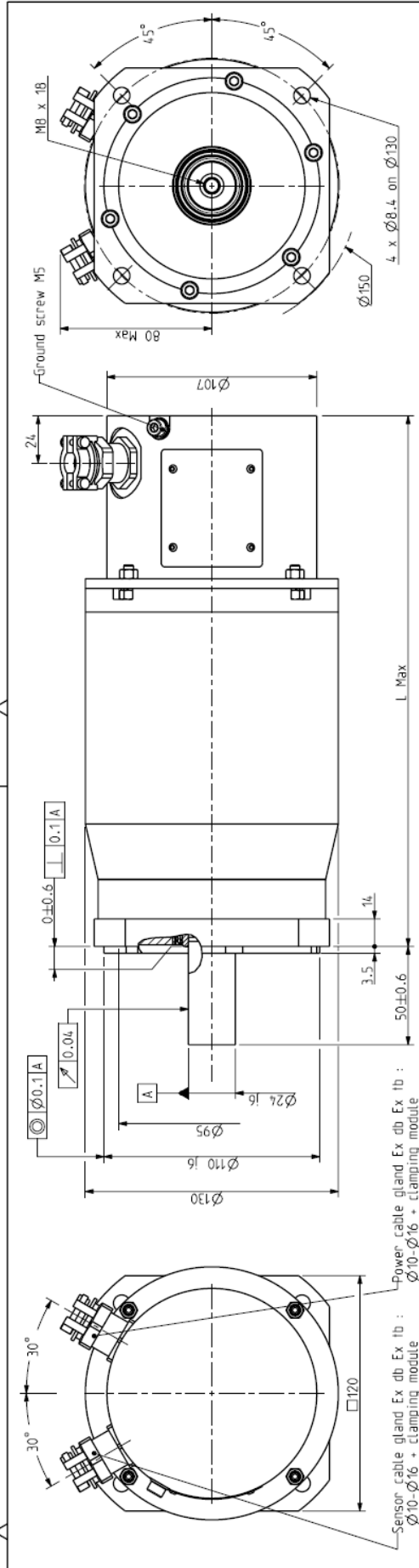

W. ITH KEY 		W. EIGHT <table border="1"> <tr> <td>Motor w/ithout brake</td> <td>10 Kg</td> <td>EX620</td> <td>12 N.m</td> <td>8 N.m</td> </tr> <tr> <td>Motor w/ithout brake w/ith brake</td> <td>11 Kg</td> <td>EX630</td> <td>12 N.m</td> <td>8 N.m</td> </tr> <tr> <td></td> <td>12.5 Kg</td> <td></td> <td>8 N.m</td> <td>8 N.m</td> </tr> </table>		Motor w/ithout brake	10 Kg	EX620	12 N.m	8 N.m	Motor w/ithout brake w/ith brake	11 Kg	EX630	12 N.m	8 N.m		12.5 Kg		8 N.m	8 N.m
Motor w/ithout brake	10 Kg	EX620	12 N.m	8 N.m														
Motor w/ithout brake w/ith brake	11 Kg	EX630	12 N.m	8 N.m														
	12.5 Kg		8 N.m	8 N.m														
BRAKE Supply voltage : 24 V Static torque ±10% <table border="1"> <tr> <td>20 °C</td> <td>EX620</td> <td>EX630</td> </tr> <tr> <td>100 °C</td> <td>8 N.m</td> <td>8 N.m</td> </tr> </table>		20 °C	EX620	EX630	100 °C	8 N.m	8 N.m	Standards • GB3836.1-2010 & GB3836.2-2020 • GB12476.1-2013 & GB12476.5-2013 Certification : CNEX 2021312301002774 										
20 °C	EX620	EX630																
100 °C	8 N.m	8 N.m																
IP Motor Protection Ex d IIB T4 Gb • GB3836.1-2010 & GB3836.2-2020 • GB12476.1-2013 & GB12476.5-2013		IP65 Ex d IIB T4 Gb Ex I0 A21 IP65 135°C																

EX6 E B T T C

Torque range (depends on length) | Feedback | Winding (depends on speed) | Brake | IP

0 : IP64
 1 : IP65
 Shaft
 0 : Plain shaft
 1 : With key

A : Resolver - ratio 0.5
 P : Hiperface singleturn EXS36
 B : Hiperface multiurn EXM36
 D : Hiperface singleturn EXS36
 S : Hiperface multiurn EXM36
 T : Hiperface multiurn EXS50
 U : Hiperface multiurn EXM50
 V : EnDat singleturn EGN 113
 W : EnDat multiurn EGN 1125
 Y : Sensorless

CONNECTIONS VARIANTS ON SHEET 2/2

Feedback options (feedback letter)	Resolver ratio 0.5 (A)	Sensorless (Y)	Hiperface EXS36 (P)	Hiperface EXM36 (B)	Hiperface EXS36 (S)	Hiperface EXM36 (T)	Hiperface EXS50 (U)	Hiperface EXM50 (V)	Endat EGN 113 (W)	Endat EGN 1125 (Y)
W/ithout brake L (mm)	275	275	305	305	325	325	325	325	325	325
W/ith brake L (mm)	300	300	330	330	350	350	350	350	350	350
W/ithout brake L (mm)	300	300	330	330	350	350	350	350	350	350
W/ith brake L (mm)	325	325	355	355	375	375	375	375	375	375

Dimensions

Masse :

General tolerances : DIN ISO 2768 mK

Pressline 19/03/2021 PF Vise Modifications

Sébastien Duband 1024/27-03/19

Échelle 1:2

Format A3

EX600

345413

Sheet : 1/2

3.3.8. EX820...C; EX820...C; EX820...C (CCC)

	IP Motor	IP64	IP65	Ex d IIB T4 Gb Ex tD A21 IP65 T135°C
	Protection	Ex d IIB T4 Gb		• GB3836.1-2010 & GB3836.2-20210 • GB12476.1-2013 & GB12476.5-2013
				Standards

Certification :
 CNEX 2021312301002775

BRAKE	
Supply voltage : 24V	±10%
Static torque	
EX820	EX840
36 Nm	36 Nm
32 Nm	32 Nm
32 Nm	32 Nm

WEIGHT	
Motor without brake	with brake
EX820	EX840
22 kg	25 kg
28 kg	31 kg
38 kg	41 kg

EX80E B1

Torque range
(depends on length)

Winding
(depends on speed)

Feedback

Ratio 0.5

Resolver

DSI, SIL2, EKS36

DSI, SIL2, EKM36

SKM36

SRM50

ECN 1113

ECN 1125

Brake

2 : Without brake

5 : With brake

Shaft

0 : Plain shaft

1 : With key

DIMENSIONS										
Feedback option (feedback letter)	Resolver ratio 0.5 (A)	Sensorless (Y)	Hiperface EKS36 (P)	Hiperface EKM36 (D)	Hiperface SKM36 (S)	Hiperface SRM50 (T)	Endat ECN 1113 (V)	Endat ECN 1125 (W)		
EX820	290		310	345	370	385	325			
without brake										
with brake										
EX840	325		345	370	385	420	360			
without brake										
with brake										
EX860	350		405	430	445	480	385			
without brake										
with brake										

CONNECTIONS VARIANT ON SHEET 2/2

EX800	Format	A3	F	E	S	G	I
OUTLINE DRAWING			x				
345414							

4, Bd Eiffel - CS 40090
 25604 LONGVIC CEDEX

Sébastien Duband
 Responsable technique
 Date: 2021.03.19
 Version: 01/00

Dessiné: 19/03/2021
 PF
 Vise
 Echelle: 2.5
 Modifications:

General tolerances
 DIN ISO 2768 mK

Sheet : 1/2

3.3.9. EX310U

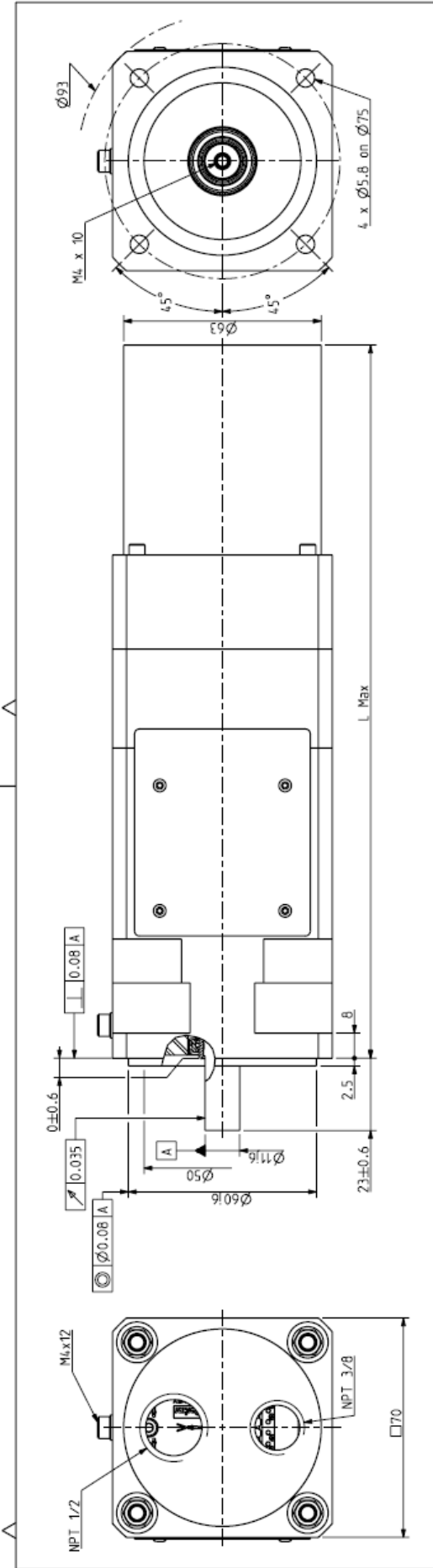

UL CERTIFIED
E302760
SAFETY US-CA

Class 1, Division 1, Group C & D
UL674 : Electric Motors and Generators
for use in Division 1 Hazardous
(classified) Locations.

WEIGHT

Without brake	2.8 kg
With brake	3.2 kg

BRAKE

Supply voltage : 24V
Static torque

EX310	2 N.m
100°C	1.8 N.m

DIMENSIONS

Feedback option (feedback letter)	Resolver ratio 0.5 (A)	Low cost resolver (X)	Sensorless (Y)	Hiperface SKS36 (R)	Hiperface SKM36 (S)	Endat ECN 1113 (V)	Endat ECN 1123 (W)
without brake			230			240	
with brake			260				270

EX310U R1

Torque range (depends on length)

Winding (depends on speed)

Feedback

Brake

IP

0 : IP64
1 : IP65

0 : Plain shaft
1 : With key

A : Resolver - ratio 0.5
R : Hiperface singletium SKS36
S : Hiperface multium SKM36
V : Endat singletium ECN 1113
W : Endat multium ECN 1123
X : Low cost resolver
Y : Sensorless

CONNECTIONS VARIANTS ON SHEET 2/2

Sheet : 1/2

Format A3

EX300U

OUTLINE DRAWING

344939

Scale 4:5

Drawn 07/09/09 00 Visa

General tolerances
DIN ISO 2768 mK

This document is the property of PARKEX. Transmission as well as reproduction or copy is not permitted without written authorization.

81 - Pvd3665_Gb_Ex_August 2022

3.3.10. EX420U EX430U

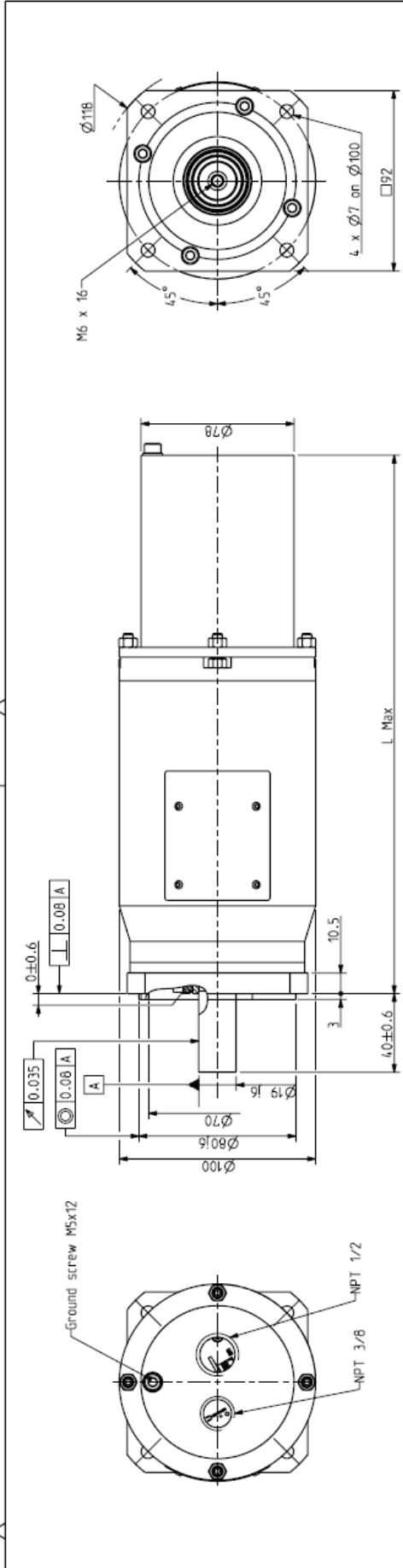

UL CERTIFIED SAFETY US-CA E302760

Class 1, Division 1, Group C & D
UL674 : Electric Motors and Generators
for use in Division 1 hazardous
(classified) Locations.

UL CERTIFIED SAFETY US-CA E302760

Class 1, Division 1, Group C & D
UL674 : Electric Motors and Generators
for use in Division 1 hazardous
(classified) Locations.

WEIGHT

Motor	W/ithout brake	W/ith brake
EX420	7 kg	8 kg
EX430	8 kg	9 kg

SHAFT END

WITH KEY

BRAKE

Supply voltage : 24 V ±10%

Static torque

Temp	EX420	EX430
20 °C	5.5 Nm	5.5 Nm
100 °C	4 Nm	4 Nm

EX420UR1

Feedback option (feedback tenary)	Resolver ratio 0.5 (A)	Low cost encoder (X)	Sensorless (Y)	Hyperface SKS36 (R)	Hyperface SKS36 (S)	Hyperface SKS50 (T)	Hyperface SP650 (U)	Endat ECN 1113 (V)	Endat ECN 1125 (W)	Torque range (depends on length)		Winding (depends on speed)		Brake		Shaft	
										W/ithout brake	W/ith brake	0	1	0	1	0	1
EX420	275	300	300	290	315	310	310	310	310	R	A	0	1	0	1	0	1
EX430	300	300	325	315	315	335	335	335	360	R	A	2	5	0	1	0	1

Feedback
 R : Resolver - ratio 0.5
 A : Hyperface singleturn SKS36
 S : Hyperface multiturn SKM36
 T : Hyperface singleturn SP550
 U : Hyperface multiturn SP650
 V : Endat singleturn ECN 1113
 W : Endat multiturn ECN 1125

Winding
 0 : Plain shaft
 1 : With key

Brake
 2 : W/ithout brake
 5 : W/ith brake

Shaft
 0 : Plain shaft
 1 : With key

Low cost encoder
 X : Low cost encoder
 Y : Sensorless

CONNECTIONS VARIANTS ON SHEET 2/2

Sheet : 1 / 2

Parker

8 Avenue de la République
21007 Dijon Cedex FRANCE
www.parker.com

EX400U

OUTLINE DRAWING

344852

Format A3

Scale 1:2

Drawn 02/10/09 00 Visa

General tolerances DIN ISO 2768 mK

This document is the property of Parker Hannifin. Its reproduction or copy is not permitted without written authorisation.

3.3.11. EX620U EX630U

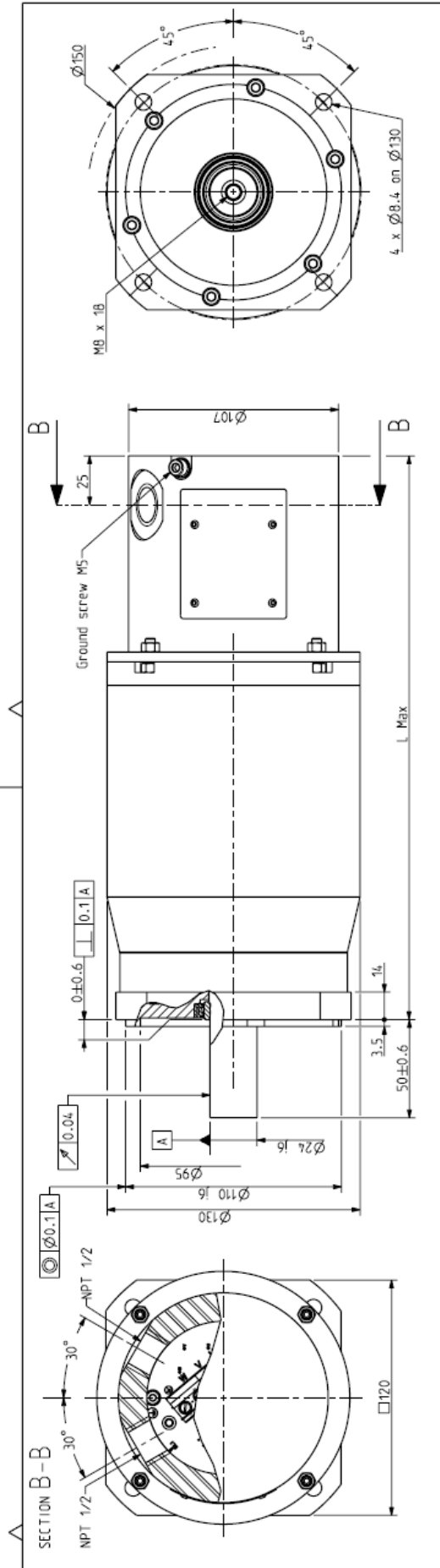

Class 1, Division 1, Group C & D
UL674 : Electric Motors and Generators
for use in Division 1 Hazardous
(classified) Locations.

BRAKE
Supply voltage : 24V --- ±10%
Static torque

	EX620	EX630
20°C	12 N.m	12 N.m
100°C	8 N.m	8 N.m

WEIGHT

Motor	without brake	with brake
EX620	10 kg	11 kg
EX630	12.5 kg	13.5 kg

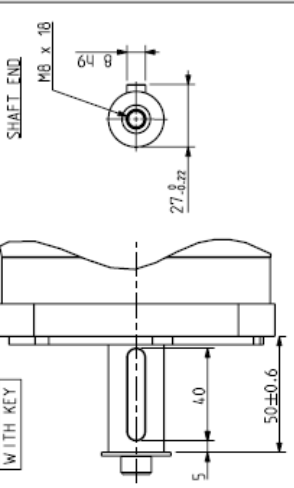

EX6_0U_R1

Torque range (depends on length) Feedback Brake Shaft

Winding (depends on speed) 0 : IP64 2 : Without brake 0 : Plain shaft

1 : IP65 5 : With brake 1 : With key

A : Resolver ratio 0.5 R : HIPERFACE singleturn SKS36 S : HIPERFACE multiturn SKM36 T : HIPERFACE singleturn SRM50 U : HIPERFACE multiturn SRM50 V : ENDAT singleturn ECN 1113 W : ENDAT multiturn ECN 1125 X : Low cost encoder Y : Sensorless

CONNECTIONS VARIANTS ON SHEET 2/2

Sheet : 1/2

Feedback option (feedback letter)	L (mm)	Resolver ratio 0.5 (A) encoder (X)	Low cost Sensorless (Y)	Sensorless (Y)	Hiperface SKS36 (R)	Hiperface SKM36 (S)	Hiperface SRM50 (T)	Hiperface SRM50 (U)	Endat ECN 1113 (V)	Endat ECN 1125 (W)
without brake	290	290	320	320	305	305	325	325	310	310
with brake	320	320	320	320	335	335	355	355	335	335
without brake	320	320	320	320	335	335	355	355	335	335
with brake	345	345	345	345	360	360	380	380	360	360

DIMENSIONS

Parker
8 Avenue du lac, BP249
21007-DIGNOY COISE-FRANCE
www.350inverter.com

Scale: 1:2

Format: A3

EX600U

OUTLINE DRAWING

344853

Sheet : 1/2

General tolerances: DIN ISO 2768 mK

Drawn: C, B, A 08/09/09 00 Visa

AM 24574, 08/07/16, SD
AM 24229, 29/04/15, AH
AM 24338, 26/09/14, AH

This document is the property of PARKEX, transmission as well as its use without written authorization.

3.3.12. EX820U EX840U EX860U

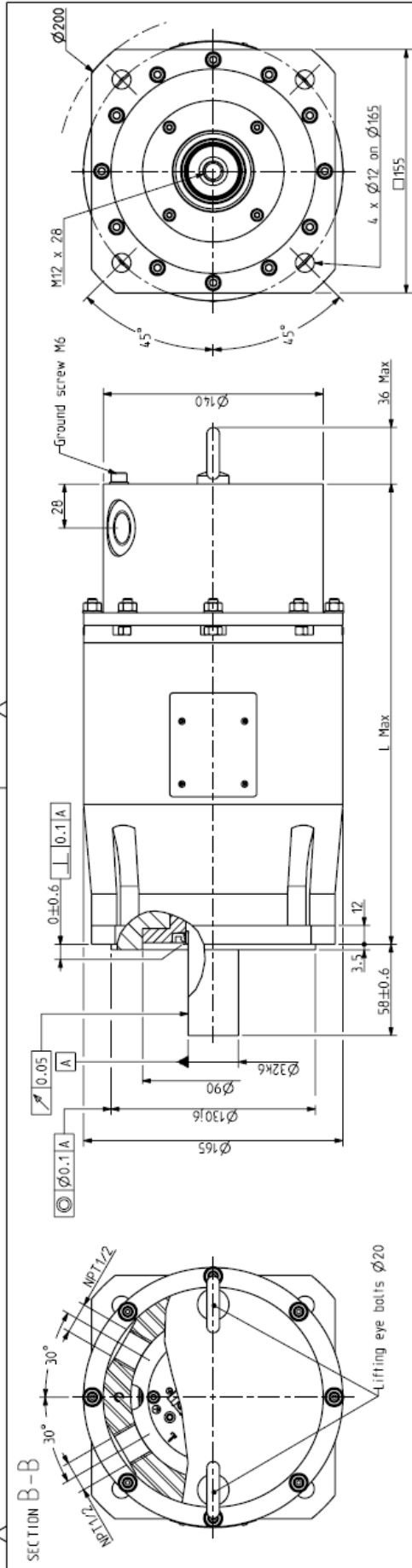

WITH KEY

UL

CERTIFIED

SAFETY US-CA

E302760

Class 1, Division 1, Group C & D
UL674 : Electric Motors and Generators
for use in Division 1 Hazardous
(classified) locations.

WEIGHT

Motor without brake	with brake	EX820	EX840	EX860
22 kg	25 kg	36 N.m	36 N.m	36 N.m
28 kg	31 kg	32 N.m	32 N.m	32 N.m
38 kg	41 kg			

BRAKE

Supply voltage : 24V ±10%

Static torque

20 °C	100 °C	EX820	EX840	EX860
36 N.m	32 N.m	32 N.m	32 N.m	32 N.m

EX80U R1

Torque range (depends on length)

Winding (depends on speed)

IP

0 : IP64
1 : IP65

Shaft

0 : Plain shaft
1 : With key

Feedback

A : Resolver - ratio 0.5
R : HIPERFACE singleturn SKS36
S : HIPERFACE multiturn SKM36
T : HIPERFACE singleturn SRM50
U : HIPERFACE multiturn SRM50
V : ENDAT singleturn ECN 113
W : ENDAT multiturn ECN 1125
X : Low cost encoder
Y : Sensorless

Brake

2 : Without brake
5 : With brake

CONNECTIONS VARIANTS ON SHEET 2/2

Feedback option (feedback letter)	Resolver ratio 0.5 (A)	Low cost encoder (X)	Sensorless (Y)	Hiperface SKS36 (R)	Hiperface SKM36 (S)	Hiperface SRM50 (T)	Hiperface SRM50 (U)	ECN 113 (V)	ECN 1125 (W)
without brake	295	330	355	310	330	330	330	335	335
with brake	330	355	390	345	365	365	365	370	370
without brake	390	415	450	370	390	390	390	395	395
with brake	390	415	450	405	425	425	425	430	430
without brake	450	465	485	430	450	450	450	455	455
with brake	450	465	485	465	485	485	485	490	490

Sheet : 1/2

Parker

8 Avenue de la République
21007 Dijon Cedex FRANCE
www.ssdiprives.com

Format : A3

EX800U

OUTLINE DRAWING

344854

Scale : 2.5

Drawn : 08/09/09

00

Visa :

General tolerances : DIN ISO 2768 mK

Modifications : A JAM 24/574 08/07/16 SD

This document is the property of Parker. Its reproduction or copy is not permitted without written authorisation.

3.4. Motor Mounting

3.4.1. Motor mounting

By flange in any direction

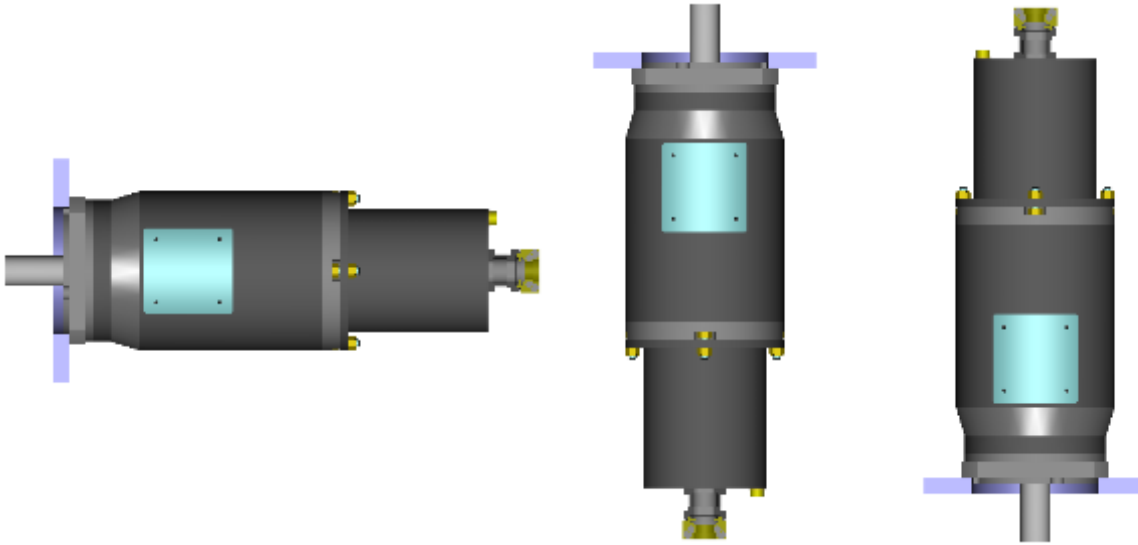

3.4.2. Installation of ATEX machines

Keep in mind that EX motors are equipments with protect mode “db” flameproof enclosure for hazardous area of gas and with protection by enclosure “tb” for hazardous area of dust ignition.



When installing electric system in hazardous locations, carefully observe the corresponding country regulations.

3.4.3. Frame recommendation

	<p><u>Warning</u> : The user has the entire responsibility to design and prepare the support, the coupling device, shaft line alignment, and shaft line balancing.</p>
---	--

Foundation must be even, sufficiently rigid and shall be dimensioned in order to avoid vibrations due to resonances.

The servomotors need a rigid support, machined and of good quality.

The maximum flatness of the support has to be lower than 0.05mm.

The motor vibration magnitudes in rms value are in accordance with IEC 60034-14 grade A:

- maximum rms vibration velocity for EX is 1.3mm/s for rigid mounting

	<p><u>Warning</u> : A grade A motor (according to IEC 60034-14) well-balanced, may exhibit large vibrations when installed in-situ arising from various causes, such as unsuitable foundations, reaction of the driven motor, current ripple from the power supply, etc.</p> <p>Vibration may also be caused by driving elements with a natural oscillation frequency very close to the excitation due to the small residual unbalance of the rotating masses of the motor.</p> <p>In such cases, checks should be carried out not only on the machine, but also on each element of the installation. (See ISO 10816-3).</p>
--	--

	<p><u>Warning</u> : A bad setting of the electronic control of the close loop (gain too high, incorrect filtering ...) can occur an instability of the shaft line, vibration or/and breakdown - . Please consult us</p>
---	---

3.5. Shaft Loads

3.5.1. Vibration resistance to shaft end

Frequency domain :10 to 55 Hz according to EN 60068 -2-6

Vibration resistance to the shaft end :

- radial 3 g
- axial 1 g

3.5.2. Maximum load acceptable on the shaft



Warning :

The values written in the table are given for a load placed on the middle of the shaft like the picture below.

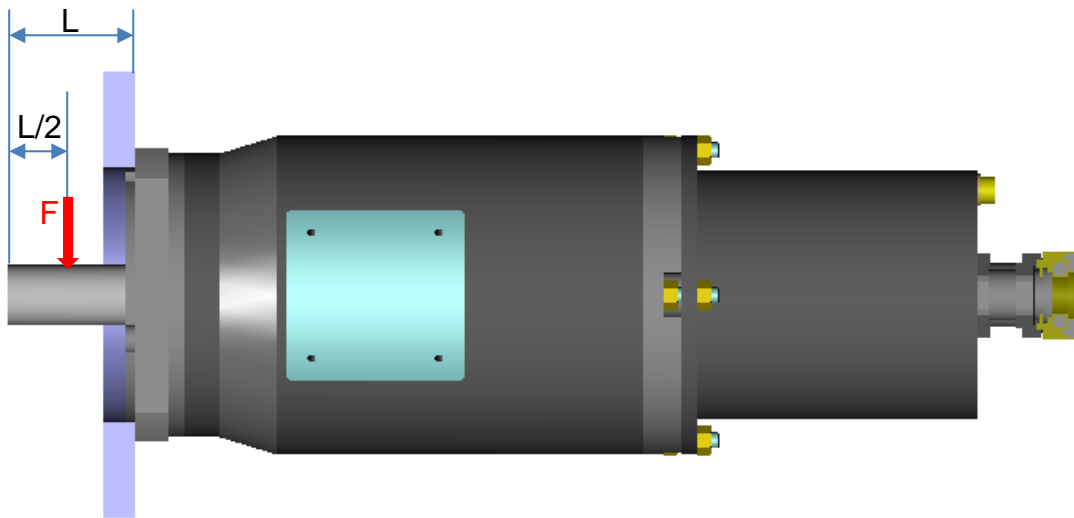

The bearing arrangement is made with 2 ball bearings (one on the shaft end + another on the rear). The rear bearing is blocked in axial translation and the front one is free in translation to avoid any stress from the shaft thermal expansion during the running.

So, it is important not to block in translation the shaft expansion by any extra bearing or similar device.



Warning :

Due to the small ATEX airgap requirements between the shaft and the front flange, the radial loads on the shaft are lower than standard NX motors.

The ATEX airgap requirements depend on the volume of the motor and can lead to lower radial loads for bigger motors.



Warning :

Regarding to these shaft loads, you must'nt use a pulley belt system without a load take-up system.

Type	Maximum shaft load F [N]
EX310	100
EX430	500
EX630	500
EX860	250

3.6. Cooling

In compliance with the IEC 60034-1 standards:

The ambient air temperature shall not be less than **-20°C** and more than **40°C**.



It is possible to use the motors in an higher ambient temperature between **40°C** to **60°C** but with an associated derating to the motor performances.



Warning: To reach the motor performances calculated, the motor must be thermally well connected to a aluminium flange with a dimension of 400 mm x 400 mm and with a thickness of 12 mm.



Caution: the ambient air temperature shall not exceed 40°C (respectively 60°C with associated derating) in the vicinity of the motor flange



Warning: A significant part of the heat produced by the motor is evacuated through the flange.

- if the air is not able to circulate freely around the motor,
- if the motor is mounted on a surface that dissipates not well the heating (surface with little dimensions for instance),
- if the motor is thermally isolated,
- if the motor is mounted on a warm surface (mounted on a gearbox for instance),

then the motor has to be used at a torque less than the rated torque.

3.7. Thermal Protection

The drive guarantees a 1st level of safety but it is not sufficient. Safety is guaranteed by the independent relay system described in the connection diagram (§4.3.3) which constitutes an independent protection circuit meeting safety classification SIL2 in accordance with the standard IEC 61508.

In the motor, there are two kinds of thermal sensors used for the safety. Both devices are wired in-series with the coil of the drive power contactor.

- Two thermostiches fitted in the servomotor coil mean that the circuit is mechanically opened on a basis at $125^{\circ}\text{C}\pm 5^{\circ}\text{C}$. This protection is reversible, after a decreasing of the temperature under the basis, the circuit is mechanically closed.
- A thermofuse fitted with a contact on the servomotor frame means that the circuit is mechanically opened on a permanent basis at $130^{\circ}\text{C}-5^{\circ}\text{C}$. In case of an over temperature and thermostiches default, the thermo fuse cuts off permanently the power supply to the contactor coil.

Both thermostiches and thermofuse are wired in-series with the coil of the drive power contactor. If the maximum temperature is reached, the thermostiches are opened and temporarily cut off the power supply to the contactor coil. If the temperature reaches a dangerous level (thermostiches default), the thermofuse melts; permanently cutting off the power supply to the contactor coil.

The drive can be equipped with a Safe Torque Off function in accordance with EN ISO13849-1 : 2006 and EN 61800-5-2:2006 and validated by a notified organization. In this case the safety system can be connected to this function with a validation of a notified organization.

Caution : (see diagrams §4.3.3) :

- Make sure the parameters of the contactor and the connecting are strictly followed.
- The motor is out of order if the thermofuse is activated!
- The power contactor KM1 should be replaced in accordance with its operation lifespan and number of manoeuvres. A yearly test, intended to check on the ability of the contactor to detect condition changes, should also be carried out.
- The thermal sensors, due to their thermal inertia, are unable to follow very fast winding temperature variations. They acheive their thermal steady state after a few minutes.



Warning: To protect correctly the motor against very fast overload, please refer to 3.1.6. Peak current limitations

3.8. Power Electrical Connections

3.8.1. Inlet cables for ATEX/IECEx version.

The servomotors EX have two cable glands with metric thread :one for the feedback cable and the other for the power. These cable glands are place in axial or radial position on the feedback cover depending the motor option.

The informations of these cable glands are placed in the §4.4.

The cable gland expected for the feedback cable could be replace by an ATEX thread cap in case of a servomotor in sensorless.

It is forbidden to change a cable gland without the Parker agreement.

3.8.2. Wires sizes



In every country, you must respect all the local electrical installation regulations and standards.

Not limiting example in France: NFC 15-100 or IEC 60364 as well in Europe.



Cable selection depends on the cable construction, so refer to the cable technical documentation to choose wire sizes



Some drives have cable limitations or recommendations; please refer to the drive technical documentation for any further information.

Cable selection



At standstill, the current must be limited at 80% of the low speed current I_0 and cable has to support peak current for a long period. So, if the motor works at standstill, the current to select wire size is $\sqrt{2} \times 0.8 I_0 \cong 1,13 \times I_0$.



For the ATEX installations in ambient temperature of 40°C or 60°C, you have to use special cables C2 type auto-extinguish regarding the standard EN 50265-2-1.

Warning : the cables used in the :

- EX3 can reach a temperature of 80°C,
- EX4 can reach a temperature of 91°C,
- EX6 can reach a temperature of 95°C,
- EX8 can reach a temperature of 94°C.

Warning : for a safe use, the EX3 servomotors has to be used with cable which withstand a maximum temperature of 80°C.

Warning : for a safe use, the EX4/EX6/EX8 servomotors has to be used with cable which withstand a maximum temperature of 100°C.



	<p>It is mandatory to connect 2 (green-yellow) ground cables between the motor frame and machine.</p> <ul style="list-style-type: none"> •the first one is connected to ground screw on the PCB inside the motor, •the other one is connected to the external motor housing <p>The connecting of these two grounding devices is mandatory in order to comply with ATEX standard IEC/EN 60079-0.</p> <p>The ground cable cross-section must be the same as the power cable cross-section</p>
---	---

3.8.3. Conversion Awg/kcmil/mm²:

Awg	kcmil	mm ²
	500	253
	400	203
	350	177
	300	152
	250	127
0000 (4/0)	212	107
000 (3/0)	168	85
00 (2/0)	133	67.4
0 (1/0)	106	53.5
1	83.7	42.4
2	66.4	33.6
3	52.6	26.7
4	41.7	21.2
5	33.1	16.8
6	26.3	13.3
7	20.8	10.5
8	16.5	8.37
9	13.1	6.63
10	10.4	5.26
11	8.23	4.17
12	6.53	3.31
14	4.10	2.08
16	2.58	1.31
18	1.62	0.82
20	1.03	0.52
22	0.63	0.32
24	0.39	0.20
26	0.26	0.13

3.8.4. Motor cable length

For motors windings which present low inductance values or low resistance values, the own cable inductance, respectively own resistance, in case of large cable length can greatly reduce the maximum speed of the motor. Please contact PARKER for further information.

	<p><u>Caution:</u> It might be necessary to fit a filter at the servo-drive output if the length of the cable exceeds 25 m. Consult us.</p>
	<p>The length of the cable must be of 3 meters min.</p>

3.8.5. Mains supply connection diagrams

3.8.5.1. EX310E

<p style="text-align: center;">Resolvers and CR410 connection Feedback letter : A/E/G</p> <p>U : Phase U V : Phase V W : Phase W TH+ : Thermic protector TH- : Thermic protector BR+ : Brake- (option) BR- : Brake+ (option) S1 : Resolver 1 S2 : Resolver 2 S3 : Resolver 3 S4 : Resolver 4 R1 : Resolver 5 R2 : Resolver 6 B : Shield option (screw M3)</p> <p style="text-align: center;">SCALE : 3/2</p> <p style="text-align: center;">⊕ Ground</p>	<p style="text-align: center;">Resolutionless connection Feedback letter : Y</p> <p>U : Phase U V : Phase V W : Phase W TH+ : Thermic protector TH- : Thermic protector BR+ : Brake- (option) BR- : Brake+ (option) B : Shield option (screw M3)</p> <p style="text-align: center;">SCALE : 3/2</p> <p style="text-align: center;">⊕ Ground</p>	<p style="text-align: center;">Hiperface connection Feedback letter : R/S</p> <p>U : Phase U V : Phase V W : Phase W TH+ : Thermic protector TH- : Thermic protector BR+ : Brake- (option) BR- : Brake+ (option) 1 : Encoder US 2 : Encoder gnd 3 : Encoder refSIN 4 : Encoder refCOS 5 : Encoder DATA + 6 : Encoder DATA - 7 : Encoder +SIN 8 : Encoder +COS B : Shield option (screw M3)</p> <p style="text-align: center;">SCALE : 3/2</p> <p style="text-align: center;">⊕ Ground</p>
<p style="text-align: center;">Low cost encoder connection Feedback letter : X</p> <p>U : Phase U V : Phase V W : Phase W TH+ : Thermic protector TH- : Thermic protector BR+ : Brake- (option) BR- : Brake+ (option) 1 : A 2 : A' 3 : B 4 : B' 5 : Z 6 : Z' 7 : 0 8 : Vcc B : Shield option (screw M3)</p> <p style="text-align: center;">SCALE : 3/2</p> <p style="text-align: center;">⊕ Ground</p>	<p style="text-align: center;">Encoder SETTINGS</p> <p>Resolver setting Feedback letter : A/E/G Motor powered by direct current at the current nominal value (W+ and V-). The shift is 90° electrical.</p> <p>Hiperface SKS/SKM setting Feedback letter : R/S Motor powered by direct current at the current nominal value (W+ and V-). Value in encoder memory is 205.</p> <p>Low cost encoder setting Feedback letter : X Engine driven clockwise shaft end side. Switching signal V is in phase with FEM UV.</p>	<p style="text-align: center;">Resolutionless connection Feedback letter : Y</p> <p>U : Phase U V : Phase V W : Phase W TH+ : Thermic protector TH- : Thermic protector BR+ : Brake- (option) BR- : Brake+ (option) B : Shield option (screw M3)</p> <p style="text-align: center;">SCALE : 3/2</p> <p style="text-align: center;">⊕ Ground</p>
<p style="text-align: center;">Certification : INERIS 03ATEX0060X INE 15.0060X</p>		
<p style="text-align: center;">Echelle : 3:10</p>		
<p style="text-align: center;">Parker 1, Bd. Eiffel, CS 10090 25004 LONGVICY CEDEX</p>		
<p style="text-align: center;">EX300</p>		
<p style="text-align: center;">OUTLINE DRAWING</p>		
<p style="text-align: center;">Format : A3</p>		
<p style="text-align: center;">Sheet : 2/2</p>		
<p style="text-align: center;">344487</p>		
<p style="text-align: center;">E</p>		

3.8.5.2. EX420E, EX430E

Resolver connection Feedback letter : A/G

U : Phase U
V : Phase V
W : Phase W
TH- : Thermic protector
TH+ : Thermic protector
BR- : Brake - (option)
BR+ : Brake + (option)
S1 : Resolver 1
S2 : Resolver 2
S3 : Resolver 3
S4 : Resolver 4
R1 : Resolver 5
R2 : Resolver 6
B : Shield option (screw M3)
⊕ : Ground

SCALE : 3/2

Rotar is rotating in clockwise viewed from shaft end view.

Low cost encoder connection Feedback letter : X

U : Phase U
V : Phase V
W : Phase W
TH- : Thermic protector
TH+ : Thermic protector
BR- : Brake - (option)
BR+ : Brake + (option)
1 : A
2 : A'
3 : B
4 : B'
5 : Z
6 : Z'
7 : 0
8 : Vcc
B : Shield option (screw M3)
⊕ : Ground

SCALE : 3/2

Hi-perface connection Feedback letter : R/S/T/U

U : Phase U
V : Phase V
W : Phase W
TH- : Thermic protector
TH+ : Thermic protector
BR- : Brake - (option)
BR+ : Brake + (option)
1 : Encoder Us
2 : Encoder gnd
3 : Encoder refSIN
4 : Encoder refCOS
5 : Encoder Data +
6 : Encoder Data -
7 : Encoder +SIN
8 : Encoder -COS
B : Shield option (screw M3)
⊕ : Ground

SCALE : 3/2

Sensorless connection Feedback letter : Y

U : Phase U
V : Phase V
W : Phase W
TH- : Thermic protector
TH+ : Thermic protector
BR- : Brake - (option)
BR+ : Brake + (option)
B : Shield option (screw M3)
⊕ : Ground

SCALE : 3/2

Certification :
INERS 04ATEX0097X
INE 15.0060X

ENCODER SETTINGS

<p>Resolver setting Feedback letter : A/G</p> <p>Motor powered by direct current at the current nominal value (W+ and V-). The shift is 90° electrical.</p>	<p>Hi-perface SSS/SRM setting Feedback letter : R/S</p> <p>Motor powered by direct current at the current nominal value (W+ and V-). Value in encoder memory is Z05.</p>
<p>Hi-perface SSS/SRM setting Feedback letter : T/U</p> <p>Motor powered by direct current at the current nominal value (W+ and V-). Value in encoder memory is 1638.</p>	<p>Low cost encoder setting Feedback letter : X</p> <p>Engine driven clockwise shaft and side. Switching signal V FEH UV.</p>

Masse :		<table border="1" style="width: 100%; border-collapse: collapse;"> <tr> <th>Designe</th> <th>29/07/09</th> <th>SD</th> <th>Vise</th> </tr> <tr> <td>C</td> <td>AM 24229</td> <td>03/12/13</td> <td>AH</td> </tr> <tr> <td>B</td> <td>AM 24108</td> <td>22/04/13</td> <td>SD</td> </tr> <tr> <td>A</td> <td>AM 23304</td> <td>10/12/09</td> <td>SD</td> </tr> </table>	Designe	29/07/09	SD	Vise	C	AM 24229	03/12/13	AH	B	AM 24108	22/04/13	SD	A	AM 23304	10/12/09	SD	<table border="1" style="width: 100%; border-collapse: collapse;"> <tr> <th>General tolerances</th> </tr> <tr> <td>DIN ISO 2768 mK</td> </tr> </table>	General tolerances	DIN ISO 2768 mK
Designe	29/07/09	SD	Vise																		
C	AM 24229	03/12/13	AH																		
B	AM 24108	22/04/13	SD																		
A	AM 23304	10/12/09	SD																		
General tolerances																					
DIN ISO 2768 mK																					
<table border="1" style="width: 100%; border-collapse: collapse;"> <tr> <td style="width: 50%;">Echelle 1:2</td> <td style="width: 50%;">E AM 24677 27/04/17 TD</td> </tr> <tr> <td colspan="2" style="text-align: center;">D AM 24578 22/07/16 SD</td> </tr> </table>		Echelle 1:2	E AM 24677 27/04/17 TD	D AM 24578 22/07/16 SD		<table border="1" style="width: 100%; border-collapse: collapse;"> <tr> <td style="width: 20%;">Format A3</td> <td style="width: 20%;">F</td> <td style="width: 20%;">E</td> <td style="width: 20%;">S</td> <td style="width: 20%;">G</td> <td style="width: 20%;">I</td> </tr> <tr> <td colspan="6" style="text-align: center;">x</td> </tr> </table>	Format A3	F	E	S	G	I	x								
Echelle 1:2	E AM 24677 27/04/17 TD																				
D AM 24578 22/07/16 SD																					
Format A3	F	E	S	G	I																
x																					
<p>4 BA Eiffel CS 40990 26004 LONGVIC CODEX</p>		<p>EX400</p> <p>OUTLINE DRAWING</p>		<p>344619</p>																	
Sheet : 2/2																					

Resolver connection
Feedback letter : A/G

U : Phase U
V : Phase V
W : Phase W
TH+ : Thermic protector
TH- : Thermic protector
BR+ : Brake - (option)
BR- : Brake - (option)
S1 : Resolver 1
S2 : Resolver 2
S3 : Resolver 3
S4 : Resolver 4
R1 : Resolver 5
R2 : Resolver 6
B : Shield option (screw M4)
⊕ : Ground

Scale : 2/3

Low cost encoder connection
Feedback letter : X

U : Phase U
V : Phase V
W : Phase W
TH+ : Thermic protector
TH- : Thermic protector
BR+ : Brake - (option)
BR- : Brake - (option)
1 : A
2 : A'
3 : B
4 : B'
5 : Z
6 : Z'
7 : 0
8 : Vcc
B : Shield option (screw M4)
⊕ : Ground

Scale : 2/3

Hiiperface connection
Feedback letter : R/S/T/U

U : Phase U
V : Phase V
W : Phase W
TH+ : Thermic protector
TH- : Thermic protector
BR+ : Brake - (option)
BR- : Brake - (option)
1 : Encoder Us
2 : Encoder refSIN
3 : Encoder refCOS
4 : Encoder Data +
5 : Encoder Data -
6 : Encoder + SIN
7 : Encoder + COS
B : Shield option (screw M4)
⊕ : Ground

Scale : 2/3

Certification :
INERIS 04-ATEX0032X
INE 15-0060X

Encoder SETTINGS

Feedback letter	Setting	Description
Resolver - setting Feedback letter : A/G	Motor powered by direct current at the current nominal value (W+ and V-). The shift is 90° electrical.	
Hiiperface SKS/SKM setting Feedback letter : R/S	Motor powered by direct current at the current nominal value (W+ and V-). Value in encoder memory is 205. Value in encoder memory is 410.	
Hiiperface SRS/SRM setting Feedback letter : T/U	Motor powered by direct current at the current nominal value (W+ and V-).	
Low cost encoder setting Feedback letter : X	Engine driven clockwise shaft end side. Switching signal V is in phase with FEM UV.	

Masse	General tolerances	Dessine	07/10/09	SD	Vise	
	DIN ISO 2768 mK	C	AM 24/29	03/12/13	AH	
		B	AM 24/08	22/04/13	SD	E AM 24/677 27/04/17 TD
		A	AM 23/04	10/12/09	SD	D AM 24/578 22/07/16 SD

Format	F	E	S	G	I
A3	x	x	x	x	x

EX600

OUTLINE DRAWING

344550

E

Sheet : 2/2

3.8.5.4. EX820E, EX840E, EX860E

Resolver connection
Feedback letter : A

U : Phase U
V : Phase V
W : Phase W
TH+ : Thermic protector
TH- : Thermic protector
BR+ : Brake- (option)
BR- : Brake- (option)
S1 : Resolver 1
S2 : Resolver 2
S3 : Resolver 3
S4 : Resolver 4
R1 : Resolver 5
R2 : Resolver 6
B : Shield option (screw M4)

Scale : 2/3

Low cost encoder connection
Feedback letter : X

U : Phase U
V : Phase V
W : Phase W
TH+ : Thermic protector
TH- : Thermic protector
BR+ : Brake- (option)
BR- : Brake- (option)
1 : A
2 : A
3 : B
4 : B
5 : Z
6 : Z
7 : 0
B : Vcc
B : Shield option (screw M4)

Scale : 2/3

HiPerface connection
Feedback letter : R/S/T/U

U : Phase U
V : Phase V
W : Phase W
TH+ : Thermic protector
TH- : Thermic protector
BR+ : Brake- (option)
BR- : Brake- (option)
1 : Encoder Us
2 : Encoder gnd
3 : Encoder reSIN
4 : Encoder reCOS
5 : Encoder DATA +
6 : Encoder DATA -
7 : Encoder +SIN
8 : Encoder +COS
B : Shield option (screw M4)

Scale : 2/3

Endat connection
Feedback letter : V/W

U : Phase U
V : Phase V
W : Phase W
TH+ : Thermic protector
TH- : Thermic protector
BR+ : Brake- (option)
BR- : Brake- (option)
1 : Encoder up 5V ±5%
2 : Encoder 0V
3 : Encoder A+
4 : Encoder A-
5 : Encoder B+
6 : Encoder B-
7 : Encoder Data
8 : Encoder Data
9 : Encoder Clock
10 : Encoder Clock
B : Shield option (screw M4)

Scale : 2/3

HiPerface connection
Feedback letter : R/S/T/U

U : Phase U
V : Phase V
W : Phase W
TH+ : Thermic protector
TH- : Thermic protector
BR+ : Brake- (option)
BR- : Brake- (option)
1 : Encoder Us
2 : Encoder gnd
3 : Encoder reSIN
4 : Encoder reCOS
5 : Encoder DATA +
6 : Encoder DATA -
7 : Encoder +SIN
8 : Encoder +COS
B : Shield option (screw M4)

Scale : 2/3

Encoder SETTINGS

Resolver setting
Feedback letter : A/G
Motor powered by direct current at the current nominal value (W+ and V-). The shift is 90° electrical.

HiPerface SRS/SRM setting
Feedback letter : R/S
Motor powered by direct current at the current nominal value (W+ and V-). Value in encoder memory is 205.

HiPerface SRS/SRM setting
Feedback letter : T/U
Motor powered by direct current at the current nominal value (W+ and V-). Value in encoder memory is 1638.

EnDat setting
Feedback letter : V/W
Motor powered by direct current at the current nominal value (W+ and V-). Value in encoder memory is 410.

Low cost encoder setting
Feedback letter : X
Motor powered by direct current at the current nominal value (W+ and V-). Value in encoder memory is 410.

EnDat setting
Feedback letter : V/W
Motor powered by direct current at the current nominal value (W+ and V-). Value in encoder memory is 410.

Certification :
INERIS OSA1EX0061X
INE 15.0060X

Sheet : 2/2

General tolerances
DIN ISO 2768 mK

Design 14/09/09 00 Vise

C AM 24578 31/01/17 TD

B AM 24108 22/04/13 SD

A AM23304 10/12/09 SD

Etelle 2:5

Format A3

344664

OUTLINE DRAWING

EX800

344664

OUTLINE DRAWING

D

3.8.5.5. EX310...C (CCC)

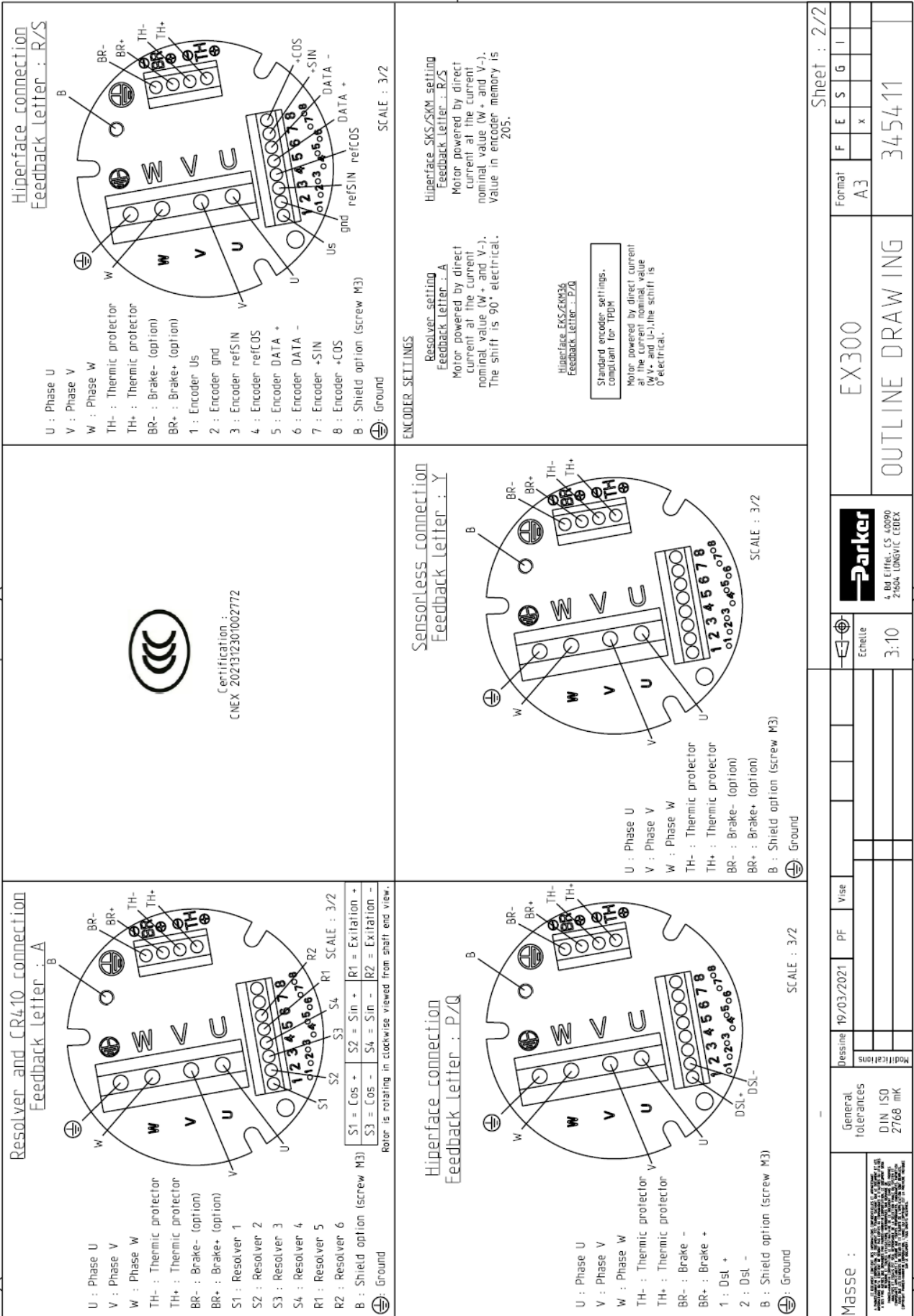

3.8.5.6. EX420...C; EX430...C (CCC)

Resolver connection

Feedback letter : A

U : Phase U
V : Phase V
W : Phase W
TH- : Thermic protector
TH+ : Thermic protector
BR- : Brake - (option)
BR+ : Brake + (option)
S1 : Resolver 1
S2 : Resolver 2
S3 : Resolver 3
S4 : Resolver 4
R1 : Resolver 5
R2 : Resolver 6
B : Shield option (screw M3)
Ground

Scale : 3/2

Motor is rotating in clockwise viewed from shaft end view.

Hiperface connection

Feedback letter : P/Q

U : Phase U
V : Phase V
W : Phase W
TH- : Thermic protector
TH+ : Thermic protector
BR- : Brake -
BR+ : Brake +
1 : Dsl +
2 : Dsl -
B : Shield option (screw M3)
Ground

Scale : 3/2

Hiperface connection

Feedback letter : R/S/T/U

U : Phase U
V : Phase V
W : Phase W
TH- : Thermic protector
TH+ : Thermic protector
BR- : Brake - (option)
BR+ : Brake + (option)
1 : Encoder Us
2 : Encoder gnd
3 : Encoder refSIN
4 : Encoder refCOS
5 : Encoder Data +
6 : Encoder Data -
7 : Encoder +SIN
8 : Encoder +COS
B : Shield option (screw M3)
Ground

Scale : 3/2

Certification :
CNEX 2021B12301002773

Resolver setting

Feedback letter : A

Motor powered by direct current at the current nominal value (W+ and V-). The shift is 90° electrical.

Hiperface SRS/SRM setting

Feedback letter : R/S

Motor powered by direct current at the current nominal value (W+ and V-). Value in encoder memory is 205.

Hiperface SRS/SRM setting

Feedback letter : T/U

Motor powered by direct current at the current nominal value (W+ and V-). Value in encoder memory is 1638.

Standard encoder settings, compliant for IPDH

Motor powered by direct current at the current nominal value (W+, and U-), the shift is 0° electrical.

Hiperface EKS/EM36
Feedback letter : P/Q

Resolver setting

Feedback letter : Y

U : Phase U
V : Phase V
W : Phase W
TH- : Thermic protector
TH+ : Thermic protector
BR- : Brake - (option)
BR+ : Brake + (option)
B : Shield option (screw M3)
Ground

Scale : 3/2

Hiperface connection

Feedback letter : Z/A

U : Phase U
V : Phase V
W : Phase W
TH- : Thermic protector
TH+ : Thermic protector
BR- : Brake - (option)
BR+ : Brake + (option)
B : Shield option (screw M3)
Ground

Scale : 3/2

Masse :

General tolerances
DIN ISO 2768 mK

Dessine : 19/03/2021

PF

Vise

Modifications

EX400

OUTLINE DRAWING

Format A3



345412

Sheet : 2/2

3.8.5.7. EX620...C; EX630...C (CCC)

<p style="text-align: center;">Resolver connection Feedback letter : A</p> <p>U : Phase U V : Phase V W : Phase W TH- : Thermic protector TH+ : Thermic protector BR- : Brake - (option) BR+ : Brake + (option) S1 : Resolver 1 S2 : Resolver 2 S3 : Resolver 3 S4 : Resolver 4 R1 : Resolver 5 R2 : Resolver 6 B : Shield option (screw M4)</p> <table border="1" style="margin-left: auto; margin-right: auto;"> <tr> <td>S1 = Cos *</td> <td>S2 = Sin *</td> <td>R1 = Excitation *</td> </tr> <tr> <td>S3 = Cos -</td> <td>S4 = Sin -</td> <td>R2 = Excitation -</td> </tr> </table> <p>Rotor is rotating in clockwise viewed from shaft end view.</p> <p style="text-align: right;">Scale : 2/3</p>	S1 = Cos *	S2 = Sin *	R1 = Excitation *	S3 = Cos -	S4 = Sin -	R2 = Excitation -	<p style="text-align: center;">Hiperface connection Feedback letter : P/Q</p> <p>U : Phase U V : Phase V W : Phase W TH- : Thermic protector TH+ : Thermic protector BR- : Brake - (option) BR+ : Brake + (option) 1 : DSL+ 2 : DSL- B : Shield option (screw M4)</p> <p style="text-align: right;">Scale : 2/3</p>	<p style="text-align: center;">Hiperface connection Feedback letter : R/S/T/U</p> <p>U : Phase U V : Phase V W : Phase W TH- : Thermic protector TH+ : Thermic protector BR- : Brake - (option) BR+ : Brake + (option) 1 : Encoder Us 2 : Encoder grnd 3 : Encoder refSIN 4 : Encoder refCOS 5 : Encoder Data + 6 : Encoder Data - 7 : Encoder + SIN 8 : Encoder + COS B : Shield option (screw M4)</p> <p style="text-align: right;">Scale : 2/3</p>															
S1 = Cos *	S2 = Sin *	R1 = Excitation *																					
S3 = Cos -	S4 = Sin -	R2 = Excitation -																					
<p style="text-align: center;">Endat connection Feedback letter : V/W</p> <p>U : Phase U V : Phase V W : Phase W TH- : Thermic protector TH+ : Thermic protector BR- : Brake - (option) BR+ : Brake + (option) 1 : Encoder Up 5V ±5% 2 : Encoder OV 3 : Encoder A + 4 : Encoder A - 5 : Encoder B + 6 : Encoder B - 7 : Encoder DATA 8 : Encoder DATA 9 : Encoder CLOCK 10 : Encoder CLOCK B : Shield option (screw M4)</p> <p style="text-align: right;">Scale : 2/3</p>	<p style="text-align: center;">Sensorless connection Feedback letter : Y</p> <p>U : Phase U V : Phase V W : Phase W TH- : Thermic protector TH+ : Thermic protector BR- : Brake - (option) BR+ : Brake + (option) B : Shield option (screw M4)</p> <p style="text-align: right;">Scale : 2/3</p>	<p style="text-align: right;">Certification : CNEX-2021312301002774</p>																					
<p style="text-align: center;">ENCODER SETTINGS</p> <table border="0" style="width:100%;"> <tr> <td style="width:33%;"> <p>Resolver setting Feedback letter : A</p> <p>Motor powered by direct current at the current nominal value (W+ and V-). The shift is 90° electrical.</p> </td> <td style="width:33%;"> <p>Hiperface SRS/SKM setting Feedback letter : RS</p> <p>Motor powered by direct current at the current nominal value (W+ and V-). Value in encoder memory is 205.</p> </td> <td style="width:33%;"> <p>Endat setting Feedback letter : V/W</p> <p>Motor powered by direct current at the current nominal value (W+ and V-). Value in encoder memory is 1638.</p> </td> </tr> <tr> <td> <p>Hiperface setting Feedback letter : P/Q</p> <p>Motor powered by direct current at the current nominal value (W+ and V-). The shift is 0° electrical.</p> </td> <td> <p>Hiperface SRS/SKM setting Feedback letter : P/Q</p> <p>Motor powered by direct current at the current nominal value (W+ and V-). The shift is 0° electrical.</p> </td> <td></td> </tr> </table>			<p>Resolver setting Feedback letter : A</p> <p>Motor powered by direct current at the current nominal value (W+ and V-). The shift is 90° electrical.</p>	<p>Hiperface SRS/SKM setting Feedback letter : RS</p> <p>Motor powered by direct current at the current nominal value (W+ and V-). Value in encoder memory is 205.</p>	<p>Endat setting Feedback letter : V/W</p> <p>Motor powered by direct current at the current nominal value (W+ and V-). Value in encoder memory is 1638.</p>	<p>Hiperface setting Feedback letter : P/Q</p> <p>Motor powered by direct current at the current nominal value (W+ and V-). The shift is 0° electrical.</p>	<p>Hiperface SRS/SKM setting Feedback letter : P/Q</p> <p>Motor powered by direct current at the current nominal value (W+ and V-). The shift is 0° electrical.</p>																
<p>Resolver setting Feedback letter : A</p> <p>Motor powered by direct current at the current nominal value (W+ and V-). The shift is 90° electrical.</p>	<p>Hiperface SRS/SKM setting Feedback letter : RS</p> <p>Motor powered by direct current at the current nominal value (W+ and V-). Value in encoder memory is 205.</p>	<p>Endat setting Feedback letter : V/W</p> <p>Motor powered by direct current at the current nominal value (W+ and V-). Value in encoder memory is 1638.</p>																					
<p>Hiperface setting Feedback letter : P/Q</p> <p>Motor powered by direct current at the current nominal value (W+ and V-). The shift is 0° electrical.</p>	<p>Hiperface SRS/SKM setting Feedback letter : P/Q</p> <p>Motor powered by direct current at the current nominal value (W+ and V-). The shift is 0° electrical.</p>																						
<p style="text-align: center;">Sheet : 2/2</p> <table border="1" style="width:100%; border-collapse: collapse;"> <tr> <td style="width:30%; text-align: center;">EX600</td> <td style="width:10%; text-align: center;">Format</td> <td style="width:10%; text-align: center;">F</td> <td style="width:10%; text-align: center;">E</td> <td style="width:10%; text-align: center;">S</td> <td style="width:10%; text-align: center;">G</td> <td style="width:10%; text-align: center;">I</td> </tr> <tr> <td style="text-align: center;">OUTLINE DRAWING</td> <td style="text-align: center;">A3</td> <td style="text-align: center;">x</td> <td style="text-align: center;">x</td> <td style="text-align: center;">x</td> <td style="text-align: center;">x</td> <td style="text-align: center;">x</td> </tr> <tr> <td colspan="6"></td> <td style="text-align: center;">345413</td> </tr> </table> <p style="text-align: right;">Parker 4 Bd Liffre - CS 40090 2804 LONGVIC CEDX</p> <p style="text-align: center;">Echelle 1:2</p>			EX600	Format	F	E	S	G	I	OUTLINE DRAWING	A3	x	x	x	x	x							345413
EX600	Format	F	E	S	G	I																	
OUTLINE DRAWING	A3	x	x	x	x	x																	
						345413																	

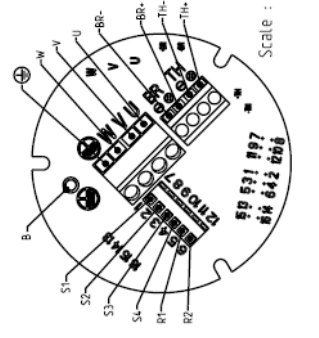
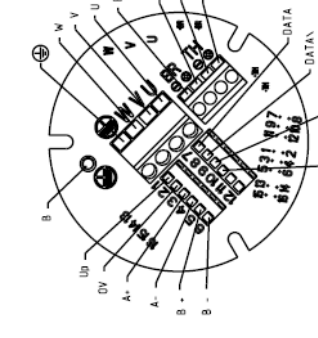
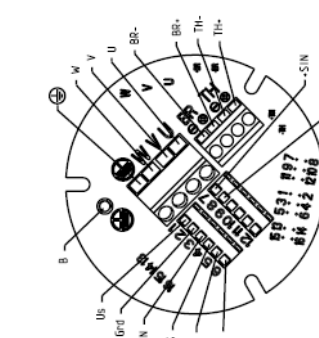
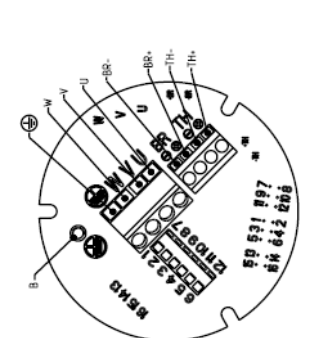
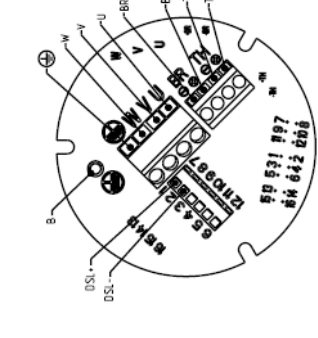
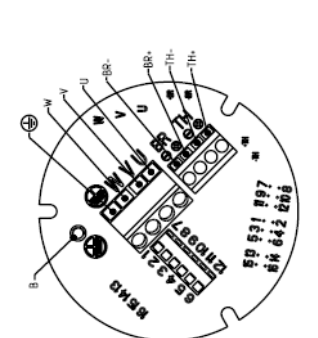
3.8.5.8. EX820...C; EX840...C; EX860...C (CCC)

<p style="text-align: center;">Resolver connection Feedback letter : A</p>  <p>U : Phase U V : Phase V W : Phase W TH- : Thermic protector TH+ : Thermic protector BR- : Brake- (option) BR+ : Brake+ (option) S1 : Resolver 1 S2 : Resolver 2 S3 : Resolver 3 S4 : Resolver 4 R1 : Resolver 5 R2 : Resolver 6 B : Shield option (screw M4)</p> <p style="text-align: right;">Scale : 2/3</p>	<p style="text-align: center;">Encoder connection Feedback letter : V/W</p>  <p>U : Phase U V : Phase V W : Phase W TH- : Thermic protector TH+ : Thermic protector BR- : Brake- (option) BR+ : Brake+ (option) 1 : Encoder OV 2 : Encoder OV 3 : Encoder A+ 4 : Encoder A- 5 : Encoder B+ 6 : Encoder B- 7 : Encoder Data 8 : Encoder Data 9 : Encoder Clock 10 : Encoder Clock B : Shield option (screw M4)</p> <p style="text-align: right;">Scale : 2/3</p>	<p style="text-align: center;">Hyperface connection Feedback letter : R/S/T/U</p>  <p>U : Phase U V : Phase V W : Phase W TH- : Thermic protector TH+ : Thermic protector BR- : Brake- (option) BR+ : Brake+ (option) 1 : Encoder US 2 : Encoder gnd 3 : Encoder refSIN 4 : Encoder refCOS 5 : Encoder DATA + 6 : Encoder DATA - 7 : Encoder +SIN 8 : Encoder +COS B : Shield option (screw M4)</p> <p style="text-align: right;">Scale : 2/3</p>																
<p style="text-align: center;">Endat connection Feedback letter : V/W</p>  <p>U : Phase U V : Phase V W : Phase W TH- : Thermic protector TH+ : Thermic protector BR- : Brake- (option) BR+ : Brake+ (option) 1 : Encoder OV 2 : Encoder OV 3 : Encoder A+ 4 : Encoder A- 5 : Encoder B+ 6 : Encoder B- 7 : Encoder Data 8 : Encoder Data 9 : Encoder Clock 10 : Encoder Clock B : Shield option (screw M4)</p> <p style="text-align: right;">Scale : 2/3</p>	<p style="text-align: center;">Hyperface connection Feedback letter : P/Q</p>  <p>U : Phase U V : Phase V W : Phase W TH- : Thermic protector TH+ : Thermic protector BR- : Brake- (option) BR+ : Brake+ (option) 1 : DSL+ 2 : DSL- B : Shield option (screw M4)</p> <p style="text-align: right;">Scale : 2/3</p>	<p style="text-align: center;">Sensorless connection Feedback letter : Y</p>  <p>U : Phase U V : Phase V W : Phase W TH- : Thermic protector TH+ : Thermic protector BR- : Brake- (option) BR+ : Brake+ (option) B : Shield option (screw M4)</p> <p style="text-align: right;">Scale : 2/3</p>																
 <p>Certification : CNEX 2021312301002775</p>																		
<p style="text-align: center;">ENCODER SETTINGS</p> <table border="0" style="width: 100%;"> <tr> <td style="width: 33%;"> <p>Resolver setting Feedback letter : A</p> <p>Motor powered by direct current at the current nominal value (W+ and V-). The shift is 90° electrical.</p> </td> <td style="width: 33%;"> <p>Hyperface_SXS/SXM setting Feedback letter : R/S</p> <p>Motor powered by direct current at the current nominal value (W+ and V-). Value in encoder memory is 205.</p> </td> <td style="width: 33%;"> <p>Encoder setting Feedback letter : V/W</p> <p>Motor powered by direct current at the current nominal value (W+ and V-). Value in encoder memory is 410.</p> </td> </tr> </table>			<p>Resolver setting Feedback letter : A</p> <p>Motor powered by direct current at the current nominal value (W+ and V-). The shift is 90° electrical.</p>	<p>Hyperface_SXS/SXM setting Feedback letter : R/S</p> <p>Motor powered by direct current at the current nominal value (W+ and V-). Value in encoder memory is 205.</p>	<p>Encoder setting Feedback letter : V/W</p> <p>Motor powered by direct current at the current nominal value (W+ and V-). Value in encoder memory is 410.</p>													
<p>Resolver setting Feedback letter : A</p> <p>Motor powered by direct current at the current nominal value (W+ and V-). The shift is 90° electrical.</p>	<p>Hyperface_SXS/SXM setting Feedback letter : R/S</p> <p>Motor powered by direct current at the current nominal value (W+ and V-). Value in encoder memory is 205.</p>	<p>Encoder setting Feedback letter : V/W</p> <p>Motor powered by direct current at the current nominal value (W+ and V-). Value in encoder memory is 410.</p>																
<table border="1" style="width: 100%; border-collapse: collapse;"> <tr> <td style="width: 20%;">General tolerances</td> <td style="width: 20%;">DIN ISO 2768 mK</td> <td style="width: 20%;">Designe 19/03/2021</td> <td style="width: 20%;">PF</td> <td style="width: 20%;">Vise</td> </tr> </table>			General tolerances	DIN ISO 2768 mK	Designe 19/03/2021	PF	Vise											
General tolerances	DIN ISO 2768 mK	Designe 19/03/2021	PF	Vise														
<table border="1" style="width: 100%; border-collapse: collapse;"> <tr> <td style="width: 20%;"></td> <td style="width: 20%;"></td> <td style="width: 20%;">Format</td> <td style="width: 20%;">F</td> <td style="width: 20%;">E</td> <td style="width: 20%;">S</td> <td style="width: 20%;">G</td> <td style="width: 20%;">I</td> </tr> <tr> <td></td> <td></td> <td>A3</td> <td>x</td> <td>x</td> <td></td> <td></td> <td></td> </tr> </table>					Format	F	E	S	G	I			A3	x	x			
		Format	F	E	S	G	I											
		A3	x	x														
<p style="text-align: center;">EX800</p> <p style="text-align: center;">OUTLINE DRAWING</p> <p style="text-align: right;">Sheet : 2/2</p> <p style="text-align: right; font-size: 24px; font-weight: bold;">345414</p>																		

3.8.5.9. EX310U

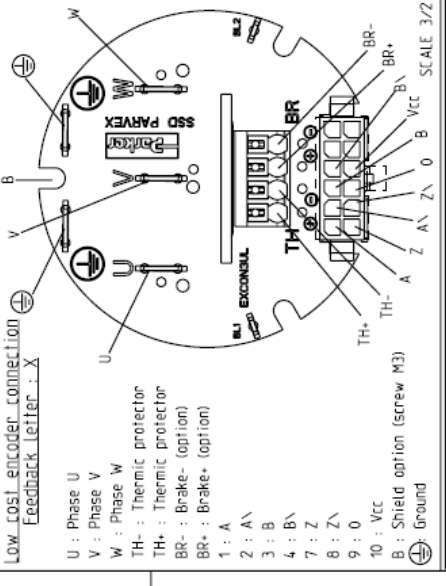
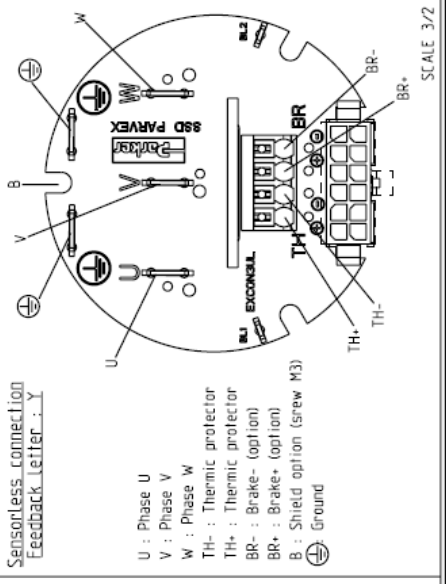
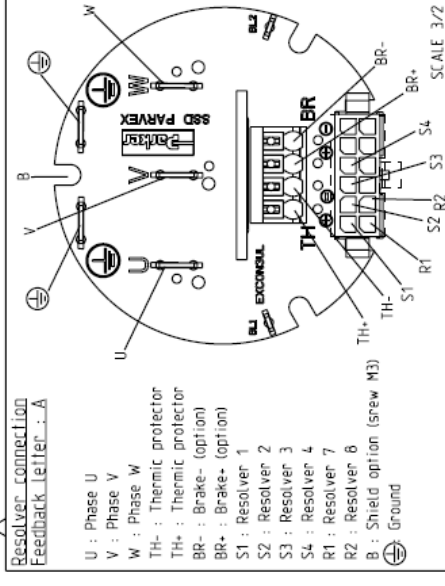
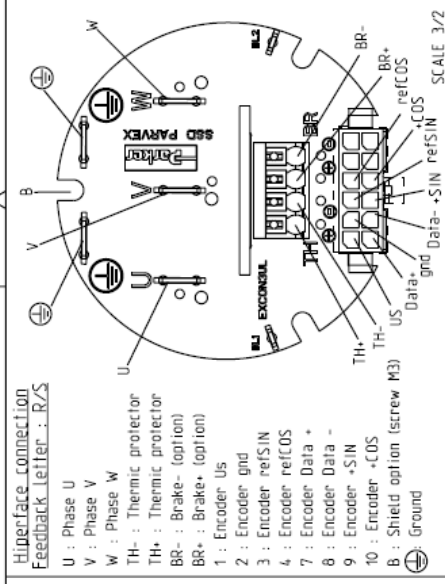
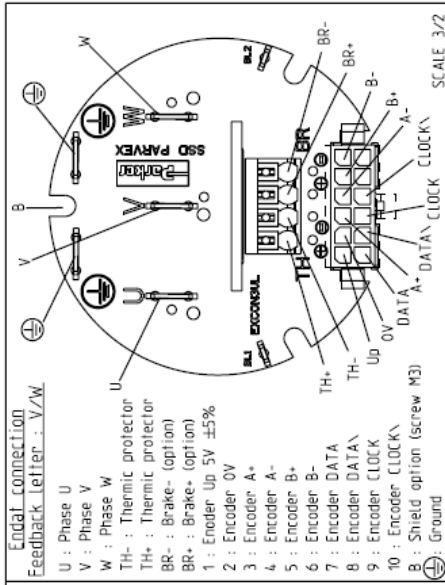

Class 1, Division 1, Group C & D
UL674 : Electric Motors and Generators
for use in Division 1 Hazardous
(classified) Locations.

ENCODER SETTINGS

Resolver setting
Feedback letter : A

Motor powered by direct current at the current nominal value (W+ and V-), the shift is 90° electrical

Hyperface SKS/SKM setting
Feedback letter : R/S

Motor powered by direct current at the current nominal value (W+ and V-), Value in encoder memory is 205

Endat setting
Feedback letter : V/W

Motor powered by direct current at the current nominal value (W+ and V-), Value in encoder memory is 470.

Low cost encoder setting
Feedback letter : X

Engine driven clockwise shaft end side. Switching signal V is in phase with FEM UV.

General tolerances	07/09/09	00	VISA	Scale	4:5	Sheet : 2/2
DIN ISO 2768 mK	B	AM 2457L	08/07/16 SD	Format	A3	F E S G I
This document is the property of PARKEX-Transmission as well as reproduction or copy is not permitted without written authorization.	A	AM2321	- 18/01/10 00	OUTLINE DRAWING	344939	B

3.8.5.10. EX420U, EX430U

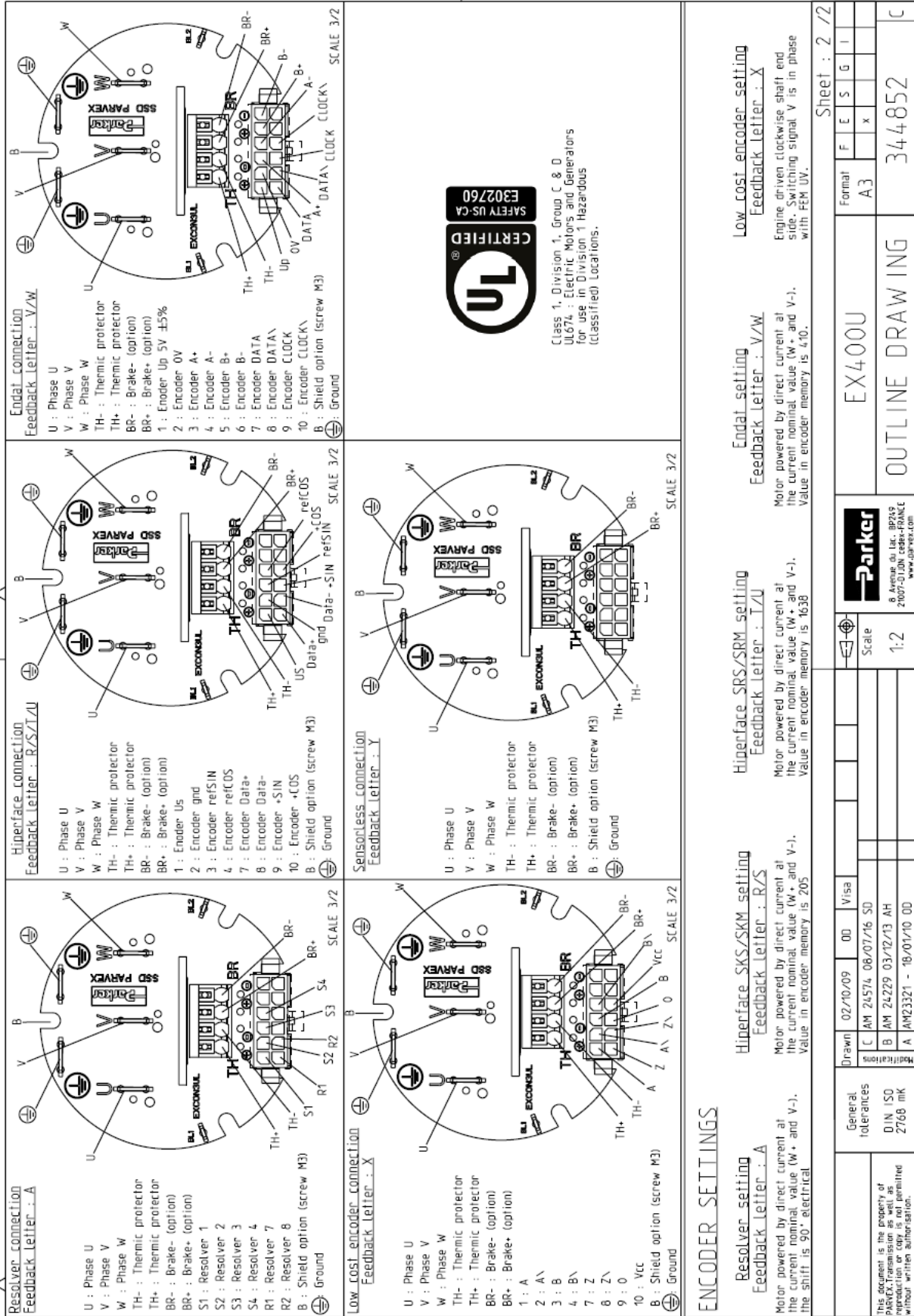

3.8.5.11. EX620U, EX630U

<p>Resolver connection Feedback Letter : A</p> <p>U : Phase U V : Phase V W : Phase W TH+ : Thermic protector TH- : Thermic protector BR+ : Brake- (option) BR- : Brake+ (option) S1 : Resolver 1 S2 : Resolver 2 S3 : Resolver 3 S4 : Resolver 4 R1 : Resolver 5 R2 : Resolver 6 B : Shield option (screw M4)</p> <p style="text-align: right;">SCALE 2/3</p>	<p>Hiperface connection Feedback Letter : R/S/T/U</p> <p>U : Phase U V : Phase V W : Phase W TH+ : Thermic protector TH- : Thermic protector BR+ : Brake- (option) BR- : Brake+ (option) 1 : Encoder Us 2 : Encoder gnd 3 : Encoder reLSIN 4 : Encoder reCOS 5 : Encoder Data + 6 : Encoder Data - 7 : Encoder +SIN 8 : Encoder +COS B : Shield option (screw M4)</p> <p style="text-align: right;">SCALE 2/3</p>	<p>Endat connection Feedback Letter : V/W</p> <p>U : Phase U V : Phase V W : Phase W TH+ : Thermic protector TH- : Thermic protector BR+ : Brake- (option) BR- : Brake+ (option) 1 : Encoder Up 5V ±5% 2 : Encoder OV 3 : Encoder A+ 4 : Encoder A- 5 : Encoder B+ 6 : Encoder B- 7 : Encoder Data 8 : Encoder Data 9 : Encoder Clock 10 : Encoder Clock B : Shield option (screw M4)</p> <p style="text-align: right;">SCALE 2/3</p>
<p>Low cost encoder connection Feedback letter : X</p> <p>U : Phase U V : Phase V W : Phase W TH+ : Thermic protector TH- : Thermic protector BR+ : Brake- (option) BR- : Brake+ (option) 1 : A 2 : A 3 : B 4 : B 5 : Z 6 : Z 7 : 0 8 : Vcc B : Shield option (screw M4)</p> <p style="text-align: right;">SCALE 2/3</p>	<p>Sensorless connection Feedback letter : Y</p> <p>U : Phase U V : Phase V W : Phase W TH+ : Thermic protector TH- : Thermic protector BR+ : Brake- (option) BR- : Brake+ (option) B : Shield option (screw M4)</p> <p style="text-align: right;">SCALE 2/3</p>	<p style="text-align: center;">UL CERTIFIED E302760 SAFETY US-CA</p> <p>Class 1, Division 1, Group C & D UL674 : Electric Motors and Generators for use in Division 1 Hazardous (classified) Locations.</p>
<p>ENCODER SETTINGS</p>		
<p>Resolver setting Feedback Letter : A</p> <p>Motor powered by direct current at the current nominal value (W+ and V-), the shift is 90° electrical</p>	<p>Hiperface SKS/SKM setting Feedback Letter : R/S</p> <p>Motor powered by direct current at the current nominal value (W+ and V-), Value in encoder memory is 205</p>	<p>Hiperface SRS/SRM setting Feedback Letter : T/U</p> <p>Motor powered by direct current at the current nominal value (W+ and V-), Value in encoder memory is 1638</p>
<p>Resolver setting Feedback Letter : A</p> <p>Motor powered by direct current at the current nominal value (W+ and V-), the shift is 90° electrical</p>	<p>Hiperface SKS/SKM setting Feedback Letter : R/S</p> <p>Motor powered by direct current at the current nominal value (W+ and V-), Value in encoder memory is 205</p>	<p>Hiperface SRS/SRM setting Feedback Letter : T/U</p> <p>Motor powered by direct current at the current nominal value (W+ and V-), Value in encoder memory is 1638</p>
<p>Resolver setting Feedback Letter : A</p> <p>Motor powered by direct current at the current nominal value (W+ and V-), the shift is 90° electrical</p>	<p>Hiperface SKS/SKM setting Feedback Letter : R/S</p> <p>Motor powered by direct current at the current nominal value (W+ and V-), Value in encoder memory is 205</p>	<p>Hiperface SRS/SRM setting Feedback Letter : T/U</p> <p>Motor powered by direct current at the current nominal value (W+ and V-), Value in encoder memory is 1638</p>
<p>Resolver setting Feedback Letter : A</p> <p>Motor powered by direct current at the current nominal value (W+ and V-), the shift is 90° electrical</p>	<p>Hiperface SKS/SKM setting Feedback Letter : R/S</p> <p>Motor powered by direct current at the current nominal value (W+ and V-), Value in encoder memory is 205</p>	<p>Hiperface SRS/SRM setting Feedback Letter : T/U</p> <p>Motor powered by direct current at the current nominal value (W+ and V-), Value in encoder memory is 1638</p>
<p>Sheet : 2/2</p>		
<p>Parker 8 Avenue du Lac BP249 21007-010N Levallois-FRANCE www.SSD.fr/eng</p>		
<p>EX600U</p>		
<p>OUTLINE DRAWING</p>		
<p>344853</p>		
<p>C</p>		

3.8.5.12. EX820U, EX840U, EX860U

<p>Resolver connection Feedback letter : A</p> <p>U : Phase U V : Phase V W : Phase W TH- : Thermic protector TH+ : Thermic protector BR- : Brake- (option) BR+ : Brake+ (option) S1 : Resolver 1 S2 : Resolver 2 S3 : Resolver 3 S4 : Resolver 4 R1 : Resolver 5 R2 : Resolver 6 B : Shield option (screw M4)</p> <p style="text-align: right;">SCALE 2/3</p>	<p>Hiperface connection Feedback letter : R/S/T/U</p> <p>U : Phase U V : Phase V W : Phase W TH- : Thermic protector TH+ : Thermic protector BR- : Brake- (option) BR+ : Brake+ (option) 1 : Encoder Us 2 : Encoder gnd 3 : Encoder refSIN 4 : Encoder refCOS 5 : Encoder Data + 6 : Encoder Data - 7 : Encoder +SIN 8 : Encoder -COS B : Shield option (screw M4)</p> <p style="text-align: right;">SCALE 2/3</p>	<p>Endat connection Feedback letter : V/W</p> <p>U : Phase U V : Phase V W : Phase W TH- : Thermic protector TH+ : Thermic protector BR- : Brake- (option) BR+ : Brake+ (option) 1 : Encoder Up 5V 45% 2 : Encoder OV 3 : Encoder A- 4 : Encoder A+ 5 : Encoder B- 6 : Encoder B+ 7 : Encoder Data 8 : Encoder Data 9 : Encoder Clock 10 : Encoder Clock B : Shield option (screw M4)</p> <p style="text-align: right;">SCALE 2/3</p>												
<p>Class 1, Division 1, Group C & D UL674 : Electric Motors and Generators for use in Division 1 Hazardous (classified) locations.</p>														
<p>Low cost encoder connection Feedback letter : X</p> <p>U : Phase U V : Phase V W : Phase W TH- : Thermic protector TH+ : Thermic protector BR- : Brake- (option) BR+ : Brake+ (option) 1 : A 2 : A' 3 : B 4 : B' 5 : Z 6 : Z' 7 : 0 B : Shield option (screw M4)</p> <p style="text-align: right;">SCALE 2/3</p>	<p>Sensorless connection Feedback letter : Y</p> <p>U : Phase U V : Phase V W : Phase W TH- : Thermic protector TH+ : Thermic protector BR- : Brake- (option) BR+ : Brake+ (option) B : Shield option (screw M4)</p> <p style="text-align: right;">SCALE 2/3</p>	<p>Encoder Settings</p> <p>Resolver setting Feedback letter : A Motor powered by direct current at the current nominal value (W+ and V-). The shift is 90° electrical.</p> <p>Hiperface SKS/SKM setting Feedback letter : R/S Motor powered by direct current at the current nominal value (W+ and V-). Value in encoder memory is 205.</p> <p>Hiperface SRS/SRM setting Feedback letter : T/U Motor powered by direct current at the current nominal value (W+ and V-). Value in encoder memory is 1638.</p> <p>Endat setting Feedback letter : V/W Motor powered by direct current at the current nominal value (W+ and V-). Value in encoder memory is 410.</p> <p>Low cost encoder setting Feedback letter : X Engine driven clockwise shaft end side. Switching signal V is in phase with FEM UV.</p>												
<p>8 Avenue du Lac, BP249 21007-DIJON Cedex-FRANCE www.SSdfr.com</p>														
<p>EX800U</p> <p>OUTLINE DRAWING</p> <p>344854</p> <p>Sheet : 2/2</p>														
<table border="1" style="width:100%; border-collapse: collapse;"> <tr> <td>Drawn</td> <td>08/09/09</td> <td>OD</td> <td>Vise</td> </tr> <tr> <td>General tolerances</td> <td colspan="3">DIN ISO 2768 mK</td> </tr> <tr> <td>Modifications</td> <td colspan="3">A JAN 24/574 08/07/16 SD</td> </tr> </table>			Drawn	08/09/09	OD	Vise	General tolerances	DIN ISO 2768 mK			Modifications	A JAN 24/574 08/07/16 SD		
Drawn	08/09/09	OD	Vise											
General tolerances	DIN ISO 2768 mK													
Modifications	A JAN 24/574 08/07/16 SD													

3.8.6. ATEX/IECEx motor connection

3.8.6.1. Connection of the power and the feedback cables with terminals

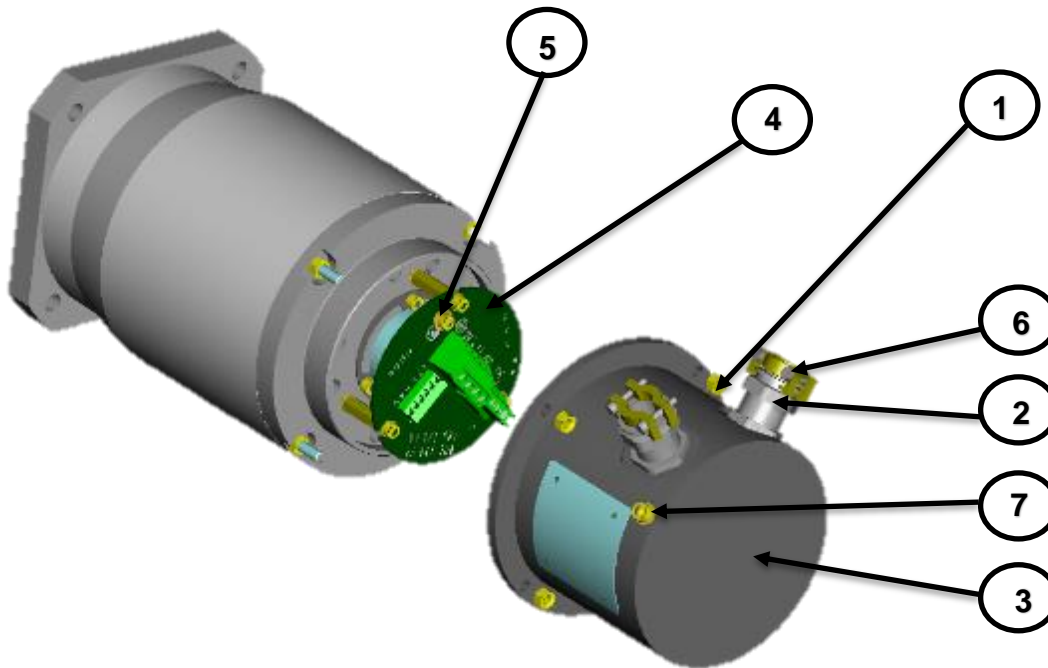

Step 1 – Remove the rear cover :

1. Unscrew the nuts for the EX3-EX4-EX6 and the screws for the EX8 Ref 1.
2. Unscrew the cable gland caps Ref 2.
3. Remove the cover Ref 3.

Step 2 – Connection of the feedback cable :

1. Insert the cable in the cable gland Ref 2.
2. Strip the wires on 3 mm.
3. Put the wires in the terminals on the PCB Ref 4 and tighten each screws at the torque value of 0,6 N.m.
4. Make the shielding connection with the connection of the terminal on the screw Ref 5 at the torque value of :

Motor size	Torque (N.m)
EX3-EX4 M3 screw	1,7
EX6-EX8 M4 screw	2,5

5. If the shielding connection is not necessary, cut the wire short the cable.

Step 3 – Connection of the power cable :

1. Insert the cable in the cable gland Ref 2.
2. Strip the wires on 3 mm.
3. Put the wires U, V, W, Ground, TH+ and TH- and also BR+ and BR- in a case of a motor with a brake in the terminal of the PCB Ref 4 and tighten each screws at the torque value of 0,6N.m.
4. Make the shielding connection with the connection of the terminal on the screw Ref 5 at the torque value of :

Motor size	Torque (N.m)
EX3-EX4 M3 screw	1,7
EX6-EX8 M4 screw	2,5

5. If the shielding connection is not necessary, cut the wire short the cable.

Step 4 – Fitting of the rear cover :

1. Slowly take up any slack in the cables and close the cover Ref 3.
2. Tighten the cable gland caps Ref 2 at the torque value of :

Cable gland size	Torque (N.m)
M16	12,5
M20	20

3. Tighten the screws of the connection modules Ref 6 at the torque value of 0,5 N.m.
4. Place the rear cover Ref 3 and take care to don't hurt the toric seal placed on the rear flange.
5. Tighten the nuts for the EX3-EX4-EX6 and the screws for the EX8 Ref 1 at the torque value of :

Motor size	Torque (N.m)
EX3-EX4-EX6 4 M5 nuts	5,6
EX8 16 screws M6	16

6. Connect the outside ground with the screw Ref 7 and tighten it at the torque value of :

Motor size	Torque (N.m)
EX3 M4 screw	2,5
EX4-EX6 M5 screw	5,6
EX8 M6 screw	8,5

3.8.6.2. Connection of the feedback and power cable with connector on EX3 :

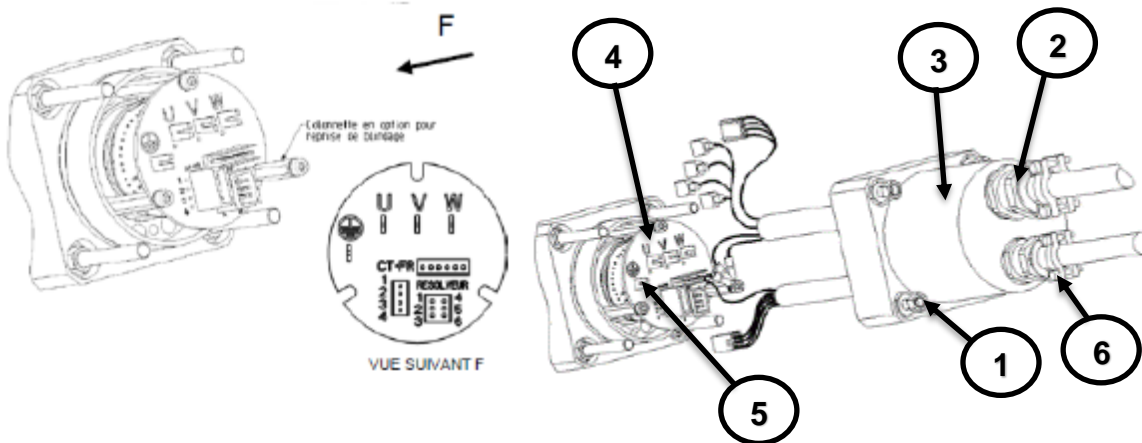

Step 1 – Remove the rear cover :

1. Unscrew the 4 nuts Ref 1.
2. Unscrew the cable gland caps Ref 2.
3. Remove the cover Ref 3.

Step 2 – Connection of the feedback cable :

1. Insert the cable in the cable gland Ref 2.
2. Strip the wires on 3 mm and crimp them in the connector.
3. Plug the connector in the terminal of the PCB Ref 4 .
4. Crimp the shielding wire in the connector and plug the connector in the terminal Ref 5.
5. If the shielding connection is not necessary, cut the wire short the cable.

Step 3 – Connection of the power cable :

1. Insert the cable in the cable gland Ref 2.
2. Strip the wires on 3 mm and crimp them in the connector.
3. Put the wires U, V, W, Ground, TH+ and TH- and also BR+ and BR- in a case of a motor with a brake equipped with their connectors on the terminal of the PCB Ref 4.
4. Crimp the shielding wire in the connector and place the connector in the terminal Ref 5.
5. If the shielding connection is not necessary, cut the wire short the cable.

Step 4 – Fitting of the rear cover :

1. Slowly take up any slack in the cables and close the cover Ref 3.
2. Tighten the cable gland caps Ref 2 at the torque value of :

Cable gland size	Torque (N.m)
M16	12,5
M20	20

3. Tighten the screws of the connection modules Ref 6 at the torque value of 0,5 N.m.
4. Place the rear cover Ref 3 and take care to don't cut the toric seal placed on the rear flange.
5. Tighten the 4 nuts Ref 1 at the torque value of 5,6 N.m.
6. Connect the outside ground with the screw Ref 7 and tighten it at the torque value of 2,5 N.m.

3.8.7. EX3-EX4 UL connection

3.8.7.1. Connection of the feedback and power cable with connector:

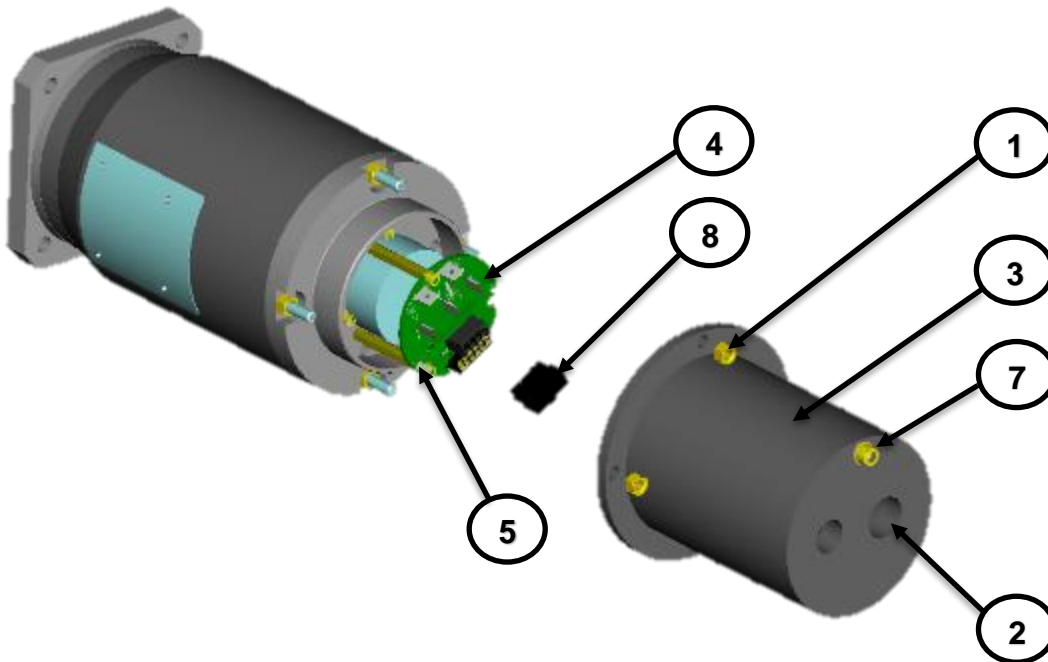

Step 1 – Remove the rear cover:

1. Unscrew the 4 nuts Ref 1.
2. Unscrew the cable gland caps Ref 2.
3. Remove the cover Ref 3.

Step 2 – Connection of the feedback cable :

1. Insert the cable in the cable gland or conduit stop Ref 2.
2. Strip the wires on 3 mm and crimp them on the contacts supplied in the terminal part kit with the manual crimp tooling Molex N°0638190000 for wire diameter AWG 20-24.
3. Place the contacts in the connector Ref 8.
4. Place the connector inside the PCB connector Ref 4.
5. Crimp the shielding wire in the connector and plug the connector in the terminal Ref 5.
6. If the shielding connection is not necessary, cut the wire short the cable.

Step 3 – Connection of the power cable :

1. Insert the cable in the cable gland or conduit stop Ref 2.
2. Strip the wires on 5mm and crimp the wires U, V, W and Ground in the faston terminals 6,8x0,8.
3. Place the wire U, V, W and Ground on the terminals and plug the wires TH+ and TH- and also BR+ and BR- in a case of a motor with a brake equipped in the terminal of the PCB Ref 4 .
4. Crimp the shielding wire in the faston terminal 2,8x0,8 and plug it on the terminal Ref 5.
5. If the shielding connection is not necessary, cut the wire short the cable.

Step 4 – Fitting of the rear cover :

1. Slowly take up any slack in the cables and close the cover Ref 3.
2. Tighten the cable gland caps or conduits stop Ref 2.
3. Tighten the screws of the connection modules Ref 6 at the torque value of 0,5 N.m.
7. Place the rear cover Ref 3 and take care to don't hurt the toric seal placed on the rear flange.
4. Tighten the 4 nuts Ref 1 at the torque value of 5,6 N.m.
5. Connect the outside ground with the screw Ref 7 and tighten it at the torque value of:

Motor size	Torque value (N.m)
EX3 M4 screw	2,5
EX4 M5 screw	5,6

3.8.8. EX6-EX8 UL connection

3.8.8.1. Connection of the feedback and power cable with terminal:

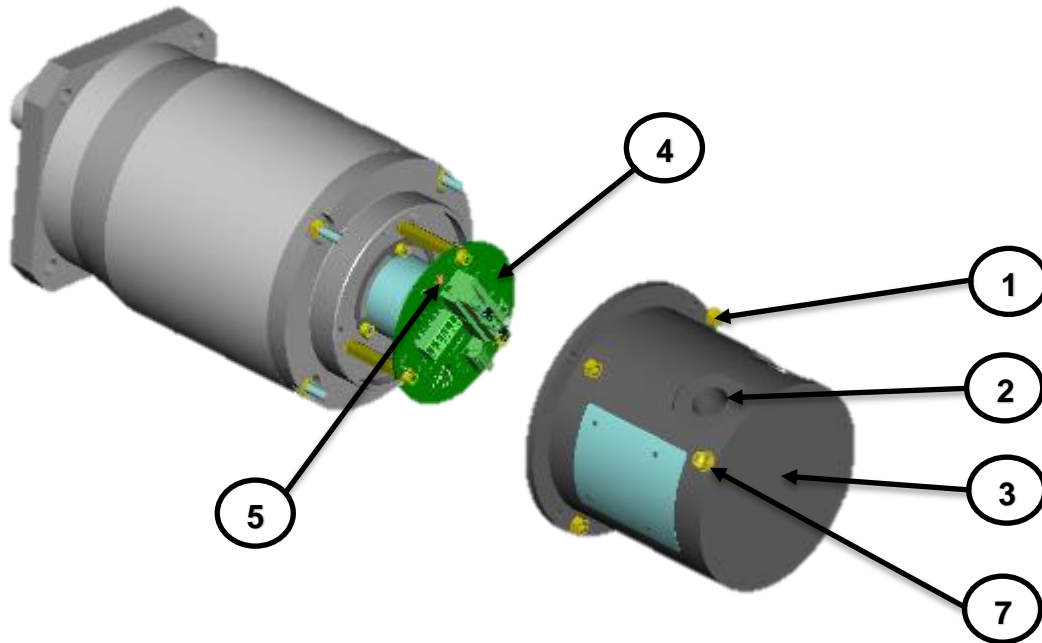

Step 1 – Remove the rear cover :

1. Unscrew the 4 nuts Ref 1.
2. Unscrew the cable gland caps Ref 2.
3. Remove the cover Ref 3.

Step 2 – Connection of the feedback cable :

1. Insert the cable in the cable gland Ref 2.
2. Strip the wires on 3 mm.
3. Put the wires in the terminals on the PCB Ref 4 and tighten each screws at the torque value of 0,6 N.m.
4. Make the shielding connection with the connection of the terminal on the screw M4 Ref 5 at the torque value of 2,5 N.m.
5. If the shielding connection is not necessary, cut the wire short the cable.

Step 3 – Connection of the power cable :

1. Insert the cable in the cable gland Ref 2.
2. Strip the wires on 3 mm.
3. Put the wires U, V, W, Ground, TH+ and TH- and also BR+ and BR- in a case of a motor with a brake in the terminal of the PCB Ref 4 and tighten each screws at the torque value of 0,6N.m.
4. Make the shielding connection with the connection of the terminal on the screw ref 5 at the torque value of 2,5 N.m.
5. If the shielding connection is not necessary, cut the wire short the cable.

Step 4 – Fitting of the rear cover :

7. Slowly take up any slack in the cables and close the cover Ref 3.
8. Tighten the cable gland caps or conduits stop Ref 2.
9. Place the rear cover Ref 3 and take care to don't hurt the toric seal placed on the rear flange.
10. Tighten the 4 nuts Ref 1 at the torque value of :

Motor size	Torque (N.m)
EX6 M5 nuts	5,6
EX8 M6 nuts	8,5

11. Connect the outside ground with the screw Ref 7 and tightent it at the torque value of :

Motor size	Torque (N.m)
EX6 M5 screw	5,6
EX8 M6 screw	8,5



3.8.9. Feedback system

3.8.10. Shaft rotation regarding the connection.

With the connection explained in the documentation and with a positive speed request on the drive, the shaft will turn in clockwise direction (see customer shaft end).

3.8.11. Resolver 2 poles transformation ratio = 0.5 – code A

	EX3	EX4, EX6 & EX8
Parker part number	220005P1001	220005P1002
Electrical specification	Values @ 8 kHz	
Polarity	2 poles	
Input voltage	7 Vrms	
Input current	86mA maximum	
Zero voltage	20mV maximum	
Encoder accuracy	± 10' maxi	
Ratio	0,5 ± 5 %	
Output impedance (primary in short circuit whatever the position of the rotor)	Typical 120 + 200j Ω	
Dielectric rigidity (50 – 60 Hz)	500 V – 1 min	
Insulation resistance	≥ 100MΩ	
Rotor inertia	~30 g.cm ²	
Operating temperature range	-55 to +155 °C	

3.8.12. Sensorless – code K or Y.

The servomotors EX in sensorless version do not have a feedback cable. The connection of the power cable has to be made regarding the connection diagrams in this documentation. In these detailed diagrams §4.3.3, do not take care the connection of the feedback cable and keep the same connections for the other devices.



3.8.13. Hiperface encoder singleturn EKS3618 bits– code P

	EX3, EX4, EX6 & EX8
Model	EKS36-2KF0B018A (Sick)
Type	Absolute single turn encoder
Parker part number	220174P0011
Electrical interface	Hiperface DSL
Position values per revolution	18 bits
Revolutions count	1
Error limits for the digital absolute value	± 120''
Operating speed	12 000 rpm
Power Supply Current consumption (without load)	7VDC to 12VDC Max 150 mA
Operating temperature range	-20°C to +115 °C
Safety	SIL 2

3.8.14. Hiperface encoder multiturn EKM36 18 bits – code Q

	EX3, EX4, EX6 & EX8
Model	EKM36-2KF0B018A (Sick)
Type	Absolute multi turn encoder
Parker part number	220174P0012
Electrical interface	Hiperface DSL
Position values per revolution	18 bits
Revolutions count	4 096
Error limits for the digital absolute value	± 120''
Operating speed	9000 rpm
Power Supply Current consumption (without load)	7VDC to 12VDC Max 150 mA
Operating temperature range	-20°C to +115 °C
Safety	SIL2



3.8.15. Hiperface encoder singleturn SKS36 (128pulses) – code R

	EX3, EX4, EX6 & EX8
Model	SKS36S-HFA0-K02 (Sick)
Type	Absolute single turn encoder
Parker part number	220174P0015
Line count	128 sine/cosine periods per revolution
Electrical interface	Hiperface
Position values per revolution	4096
Error limits for the digital absolute value	$\pm 320''$ (via RS485)
Integral non-linearity	$\pm 80''$ (Error limits for evaluating sine/cosine period)
Differential non-linearity	$\pm 40''$ (Non-linearity within a sine/cosine period)
Operating speed	12 000 rpm
Power Supply	7VDC to 12VDC
Current consumption (without load)	60mA
Output frequency	0kHz – 65kHz
Operating temperature range	-20°C to +110 °C
Safety	SIL 2

3.8.16. Hiperface encoder multiturn SKM36 (128pulses) – code S

	EX3, EX4, EX6 & EX8
Model	SKM36S-HFA0-K02 (Sick)
Type	Absolute multi turn encoder
Parker part number	220174P0016
Line count	128 sine/cosine periods per revolution
Electrical interface	Hiperface
Position values per revolution	4 096
Revolutions	4 096
Error limits for the digital absolute value	$\pm 320''$ (via RS485)
Integral non-linearity	$\pm 80''$ (Error limits for evaluating sine/cosine period)
Differential non-linearity	$\pm 40''$ (Non-linearity within a sine/cosine period)
Operating speed	9000 rpm
Power Supply	7VDC to 12VDC
Current consumption (without load)	60mA
Output frequency	0kHz – 65kHz
Operating temperature range	-20°C to +110 °C
Safety	SIL 2

3.9. Cables

You can connect EX motors to PARKER servo drives : AC30, AC890, COMPAX3, PSD or SLVD.

You can use complete cable with part number on the tabs below.

The "xxx" in the part number must be replaced by the length in meter with a minimal length of 3m.

Ex : for 20m cable, "xxx" = 020.

Special requirements for ATEX servomotors

	<p>For the ATEX installations in ambient temperature of 40°C or 60°C, you have to use special cables C2 type auto-extinguish regarding the standard EN 50265-2-1.</p> <p><u>Warning</u> : the cables used in the :</p> <ul style="list-style-type: none">• EX3 can reach a temperature of 80°C,• EX4 can reach a temperature of 91°C,• EX6 can reach a temperature of 95°C,• EX8 can reach a temperature of 94°C. <p><u>Warning</u> : for a safe use, the EX3 servomotors has to be used with cable which withstand a maximum temperature of 80°C.</p> <p><u>Warning</u> : for a safe use, the EX4/EX6/EX8 servomotors has to be used with cable which withstand a maximum temperature of 100°C.</p>
---	---



3.9.1. Cable option Max 80°C on the surface ATEX/IECEX

The servomotors EX are available on demand with cables withstanding a temperature of 80°C on the outside surface.

With this option the EX servomotors must be placed in an area with controlled temperature following the informations written in the tables just below. An over temperature must cut off the power of the motor.

Size EX4 :

	EX4 certified for an ambient temperature of -20 to +60°C
Ambient temperature for a Parker standard cable using (Max 100°C)	-20 to +60°C
Ambient temperature for an using of cables withstanding a max temperature of 80°C.	-20 to +49°C

Size EX6 :

	EX6 certified for an ambient temperature of -20 to +40°C	EX6 certified for an ambient temperature of -20 to +60°C
Ambient temperature for Parker standard cable using (Max 100°C)	-20 to +40°C	-20 to +60°C
Ambient temperature for an using of cables withstanding a max temperature of 80°C.	-20 to +27°C	-20 to +45°C

Size EX8 :

	EX8 certified for an ambient temperature of -20 to +40°C	EX8 certified for an ambient temperature of -20 to +60°C
Ambient temperature for Parker standard cable using (Max 100°C)	-20 to +40°C	-20 to +60°C
Ambient temperature for an using of cables withstanding a max temperature of 80°C.	-20 to +32°C	-20 to +46°C

3.9.2. Power & Sensor cable for PSD

Cable for use with Hiperface DSL® feedback (single cable reference 100°C) :

Drive	Current - 12 A @40°C ambient t°
	Current - 9 A @60°C ambient t°
PSD1S, PSD1M18	CBM015TD-T03-D01-xxxx-00
PSD1M (except M18)	CBM015TD-T03-D02-xxxx-00

(xxxx for length : 0100 = 10m)



Cable arrangement :

Motor terminal blocks	identification	Wire colour	Drive terminal blocks
U	U Phase	Black	M1 / U
V	V Phase	Black	M2 / V
W	W Phase	Black	M3 / W
⊕	Earth	Yellow / Green	PE
B+	Brake +	Black 5	1 / BR +
B-	Brake -	Black 6	2 / BR -
T+	Thermoswitch	Black 7	Main contactor
T-	Thermoswitch	Black 8	Main contactor
D+	DSL encoder +	White	DSL+
D-	DSL encoder -	Blue	DSL-

Power cable for use with resolver feedback (Cable reference 100°C) :

Drive	Current - 15 A @40°C ambient t°
	Current - 12 A @60°C ambient t°
PSD1S, PSD1M18	CBM015TB-T04-D01-xxxx-00
PSD1M (except M18)	CBM015TB-T04-D02-xxxx-00

(xxxx for length : 0100 = 10m)

Cable Arrangement :

Motor terminal blocks	identification	Wire colour	Drive terminal blocks
U	U Phase	Black	M1 / U
V	V Phase	Black	M2 / V
W	W Phase	Black	M3 / W
⊕	Earth	Yellow / Green	PE
B+	Brake +	Black 5	1 / BR +
B-	Brake -	Black 6	2 / BR -
T+	Thermoswitch	Black 7	Main contactor
T-	Thermoswitch	Black 8	Main contactor



Sensor cable for use with resolver feedback (Cable reference 100°C) :

CBFRE0T0-T05-D03-xxxx-00

(xxxx for length : 0100 = 10m)

Cable Arrangement :

EX Motor Terminals	identification	Wire colour	15 pins Male SuB-D HD
1	Cosine + S1	Black / White	12
2	Sine + S2	Black / Blue	8
3	Cosine - S3	White	11
4	Sine - S4	Blue	7
5	Excitation + R1	Red	4
6	Excitation - R2	Black / Red	15
	Pairs screen	Tinned copper drain	Cover

3.10. Brake option



Caution: The holding brake is used to completely immobilize the servomotor under load. It is not designed to be used for repeated dynamic braking ; dynamic braking must only be used in the case of an emergency stop and with a limited occurrence depending on the load inertia and speed.

The standard brake power supply is 24 Vcc DC \pm 10%.

Follow the polarity and the permissible voltage, and use shielded cables.

A 220 μ F capacitor avoids untimely braking if the 24 V voltage is disturbed by the external relay. Check the voltage value once this capacitor has been fitted. The RC network (220 Ω , 0.1 μ F) is needed to eliminate interference produced by the brake coil.

Position the contactor in the DC circuit to reduce brake response times. Follow the connection instructions taking the brake polarisation into account.

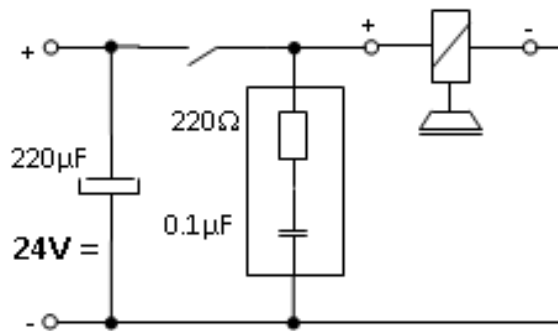

Motor	Static torque @20°C (N.m)	Static torque @100°C (N.m)	Power (W)	Engaging time (ms)	Disengaging time (ms)	Extra Inertia (Kg.m ² .10 ⁻⁵)	Angular backlash (°)
EX3	2	1.8	11	13	25	0.68	0
EX4	5.5	4	12	17	35	1.8	0
EX6	12	8	18	28	40	5.4	0
EX8	36	32	26	45	100	55.6	0

Table with typical values

4. COMMISSIONING, USE AND MAINTENANCE

4.1. Instructions for commissioning, use and maintenance

4.1.1. Equipment delivery

All servomotors are strictly controlled during manufacturing, before shipping. While receiving it, it is necessary to verify motor condition and if it has not been damaged in transit. Remove it carefully from its packaging. Verify that the data written on the label are the same as the ones on the acknowledgement of order, and that all documents or needed accessories for user are present in the packaging.



Warning: In case of damaged material during the transport, the recipient must **immediately** make reservations to the carrier through a registered mail within 24 h..

4.1.2. Handling

The servomotors EX8 are equipped with two lifting rings intended for handling.



Caution: Use only servomotors lifting rings, if present, or slings to handle the motor. Do not handle the motor with the help of electrical cables, connectors and water inputs/outputs, or use any other inappropriate method.

The drawings below show the correct handling procedure.

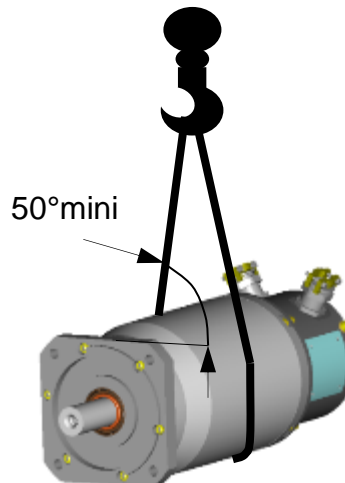

DANGER: Choose the correct slings for the motor weight. The two slings must be the same length and a minimum angle of 50° has to be respected between the motor axis and the slings.

4.1.3. Storage

Before being mounted, the motor has to be stored in a dry place, without rapid or important temperature variations in order to avoid condensation.

During storage, the ambient temperature must be kept between -20 and +60°C.

If the torque motor has to be stored for a long time, verify that the shaft end, feet and the flange are coated with corrosion proof product.

After a long storage duration (more than 3 month), run the motor at low speed in both directions, in order to blend the bearing grease spreading.

4.2. Installation

4.2.1. Mounting

Foundation must be even, sufficiently rigid and shall be dimensioned in order to avoid vibrations due to resonance. Before bolting the motor, the foundation surface must be cleaned and checked in order to detect any excessive height difference between the motor locations. The surface variation shall not exceed 0,1 mm. In all cases, we recommend using shims in order to compensate small irregularities.



Caution: The user bears the entire responsibility for the preparation of the foundation.

4.2.2. Torque value for the screws

The table below gives the average tightening torques required regarding the fixing screw diameter. These values are valid for both motor's feet and flange bolting.

Screw diameter	Tightening torque
M2 x 0.35	0.35 N.m
M2.5 x 0.4	0.6 N.m
M3 x 0.5	1.1 N.m
M3.5 x 0.6	1.7 N.m
M4 x 0.7	2.5 N.m
M5 x 0.8	5 N.m
M6 x 1	8.5 N.m
M7 x 1	14 N.m
M8 x 1.25	20 N.m

Screw diameter	Tightening torque
M9 x 1.25	31 N.m
M10 x 1.5	40 N.m
M11 x 1.5	56 N.m
M12 x 1.75	70 N.m
M14 x 2	111 N.m
M16 x 2	167 N.m
M18 x 2.5	228 N.m
M20 x 2.5	329 N.m
M22 x 2.5	437 N.m
M24 x 3	564 N.m





Warning: After 15 days, check all tightening torques on all screw and nuts.

4.2.3. Preparation

Once the motor is installed, it must be possible to access the wiring, and read the manufacturer's plate. Air must be able to circulate around the motor for cooling purposes. Clean the shaft using a cloth soaked in white spirit or alcohol. Pay attention that the cleaning solution does not get on to the bearings.

The motor must be in a horizontal position during cleaning or running.

	<p><u>Caution:</u> Do not step on the motor or the cable glands.</p>
	<p><u>Caution:</u> Always bear in mind that some parts of the surface of the motor can reach a temperature of 135°C</p>

4.2.4. Mechanical assembly

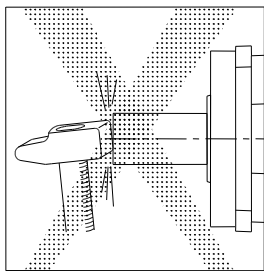

The operation life of servomotor bearings depends largely on the care and attention given to this operation.

- In the event that the servomotor shaft has a cotter pin, make sure that the coupling components have been balanced correctly without the cotter pin, the servomotor having been balanced with its cotter pin.

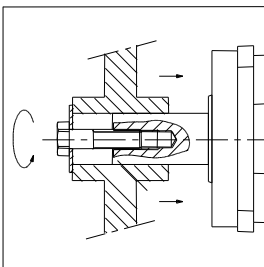

- Prohibit any impact on the shaft and avoid press fittings which could mark the bearing tracks. If press fitting cannot be avoided, it is advisable to immobilize the shaft in motion; this solution is nevertheless dangerous as it puts the resolver at risk.

- Use the thread at the end of the shaft in accordance with the diagram for fitting pulleys or accessories. It is possible to put pressure on the shoulder of the shaft located in front of the bearing.

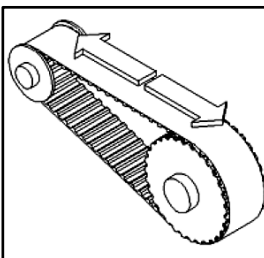



- In the event that the front bearing block is sealed by a lip seal which rubs on the rotating section (version IP 65), we recommended that you lubricate the seal with grease thus prolonging its operational life.





- In the event that the drive system uses a pulley and belt, the drive pulley must be fixed as close as possible to the flange. The pulley diameter is to be selected so that the radial load does not exceed the limits given in the catalog.



- CAUTION: Any equipment such as gearbox, mechanical speed drives, brakes, forced ventilation, integrated frequency converters, sensors, actuators, etc. associated with the motor must also have ATEX certification.

	<p>Warning : a misalignment of the coupling device makes stress and load on the motor shaft depending the rigidity of the installation. The variations of the temperature makes stress and load due to the dilatation. These loads (axials and radiale) do not exceed the load written (§ 3.5).</p>
	<p><u>Warning</u> : The misalignment of the coupling device makes vibration who can realize a destruction of the motor shaft.</p>
	<p>We cannot be held responsible for wear on the drive shaft resulting from excessive strain.</p>





4.3. Electrical connections

	<p><u>Danger</u>: Check that the power to the electrical cabinet is off prior to making any connections.</p>
	<p><u>Caution</u>: The wiring must comply with the drive commissioning manual and with recommended cables.</p>
	<p><u>Danger</u>: The motor must be earthed by connecting to an unpainted section of the motor.</p>
	<p><u>Caution</u>: After 15 days, check all tightening torques on cable connection.</p>

4.3.1. Cable connection

Please, read §3.8 "Electrical connection" to have information about cable connection
Many useful informations are already available in the drive documentations.

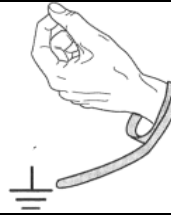
4.3.2. Encoder cable handling

	<p><u>Danger:</u> before any intervention the drive must be stopped in accordance with the procedure.</p>
	<p><u>Caution:</u> It is forbidden to disconnect the Encoder cable under voltage (high risk of damage and sensor destruction).</p>
	<p><u>Warning:</u> Always wear an antistatic wrist strap during encoder handling.</p>
	<p><u>Warning:</u> Do not touch encoder contacts (risk of damage due to electrostatic discharges ESD).</p>

4.3.3. Connection diagrams

4.3.3.1. EX3-EX4 DC supply

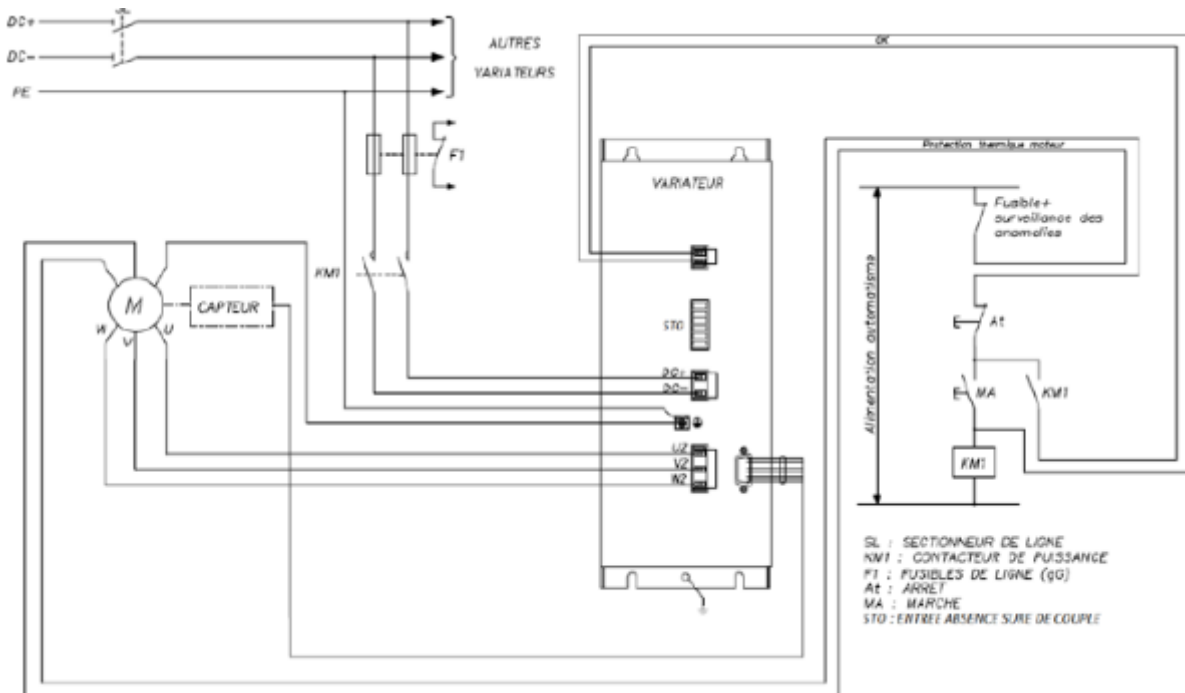

4.3.3.2. EX single phase

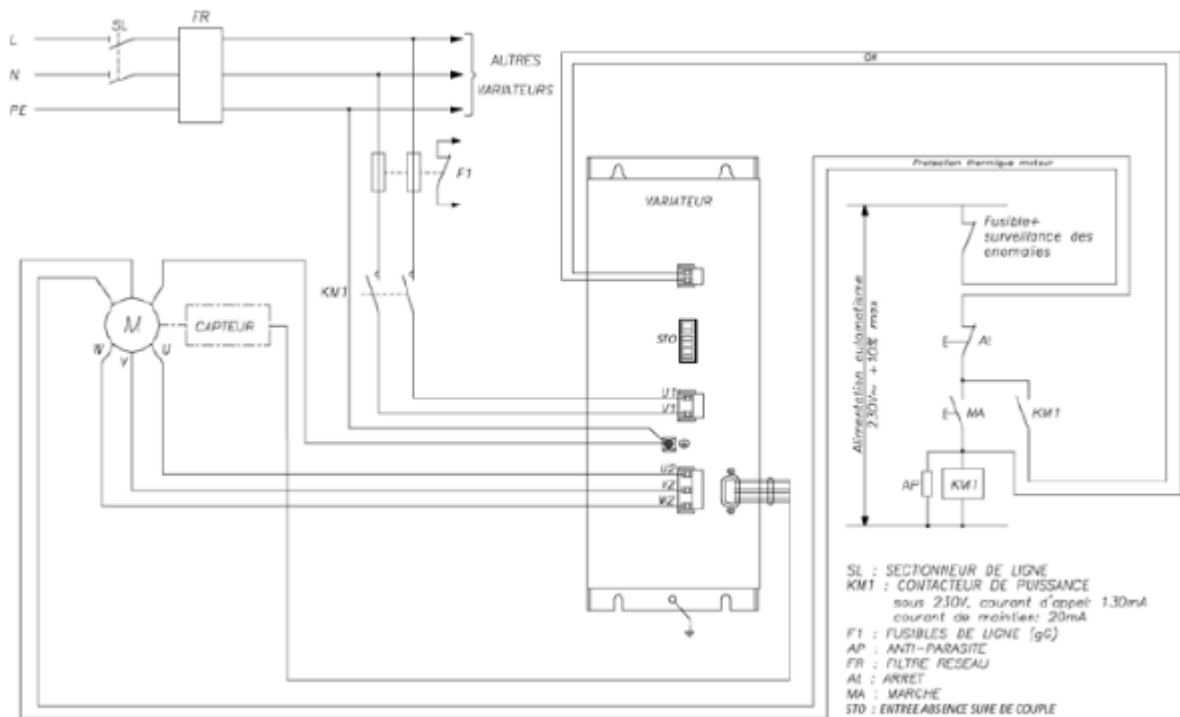

4.3.3.3. EX three phase

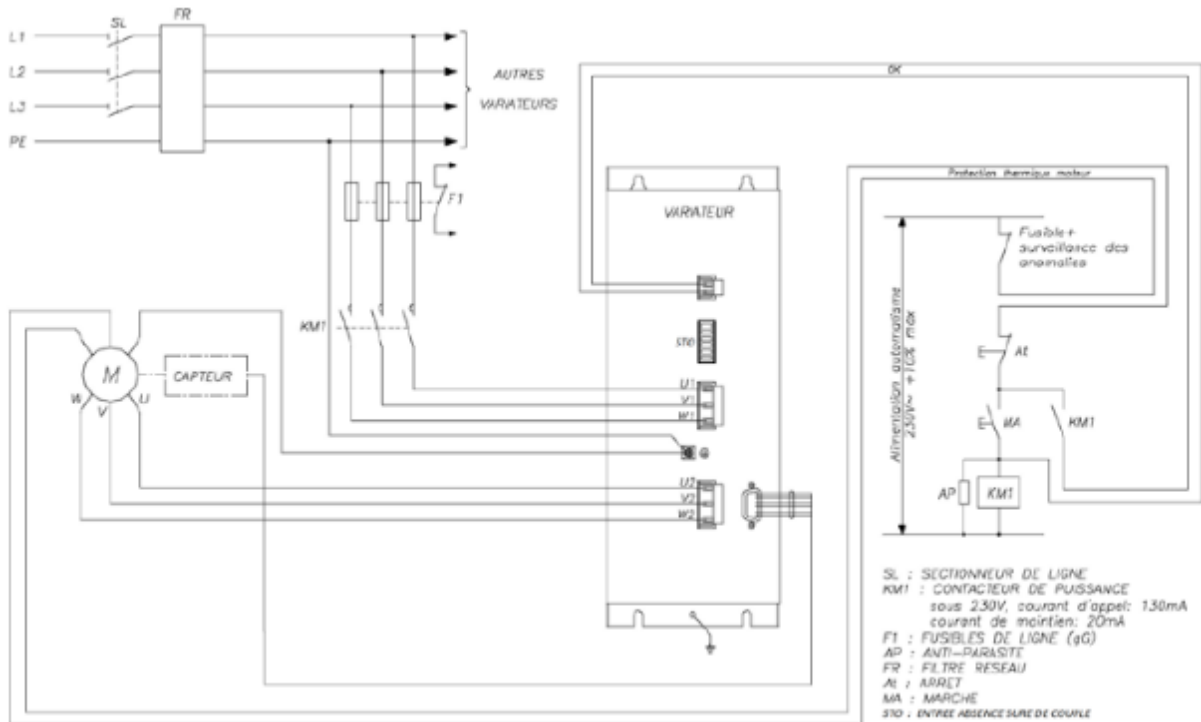

The safe torque off function is an alternative solution for the motor temperature monitoring.

The safe torque off function in accordance with the standards EN ISO 13849-1 : 2006 and EN 61800-5-2 : 2006 is an electronic system set up on some drives certified by a notified body. This is an unlocked input placed on the drive that must be connected (see the commissioning and use manual of the drive).

The servomotors EX are equipped with a thermal protection which is checked by a safety analysis and is a key element of the ATEX/IECEx safety. It is possible to connect this protection to the unlocked input or through a safety system in accordance to the drive specifications. This connection allows to maintain the drive power on, but disable the motor after the activation of the thermal protection.

After an activation of this security device, the system must not restart automatically and without a checking of the installation.

In all cases, the connection of this device must be checked and certified by a notified body.

4.3.4. Cable glands informations (Only ATEX/IECEx)

4.3.4.1. Technical data

ADE - 1F2 ISO



Type	ADE-1F2 (not for Mining application)
Certified	Ex: Ineris - Cepel - Gost-R - Nepsi - UL IIII Shipping: ABS - DNV - Lloyd's
Size	n°3 to n°17 for cable external diameter from 2,75 to 104mm Thread sizes M10 to M110 inclusive UL thread size M20 to M110 inclusive
Cable type	Unarmored cable and Marine Shipboard cable. Instrumentation-Tray-Cable (ITC), Medium Voltage (MV), Power-Limited-Tray-Cable (PLTC) and Tray Cable (TC).
Clamping	By sealing ring (25%), the user shall provide additional clamping of the cable.
Standard material	Nickel Plated Brass
Alternative material	Stainless-steel, Bronze or Aluminum.
Service Temperature	From -30 to +80°C with Neoprene sealing ring From -60 to +140°C with Silicone sealing ring
Fixing to equipment	Metric according to ISO 965-1 & 965-3
Thread Lubricant / Sealer	STL2 (2oz) or STL8 (8oz) ; Temperature range -20°F to +200°F ≈ -30°C to +95°C HTL4 (4oz) ; Temperature range -70°F to +1800°F ≈ -60°C to +1000°C
IP rating:	- On equipment with threaded hole and contact surface roughness Ra 1.6 µm maxi: * IP66 without added gasket. * IP68 tested 30m/7days with Capri qualified Fiber-Gasket. - On equipment with blank hole (not for "d" use), fixed with Capri qualified looknut, all the threads must be engaged: * IP66 depending to the flatness and the roughness of the contact surface of the enclosure: . Without added gasket for Ra 0.4 µm maxi. . With Capri qualified Fiber-Gasket for Ra 1.6 µm maxi. * IP68 tested 30m/7days with Capri qualified Fiber-Gasket for Ra 1.6 µm maxi roughness of the contact surface. - The length of the threaded entry permit to meet the applicable thread engage, also with the add of gasket between the cable gland and the enclosure (gasket thickness 1,5 or 2mm).
Deluge Compliance	DTS-01.91
ATEX Standards	INERIS: INERIS12ATEX0032X EN 60079-0:2009, EN 60079-1:2007, EN 60079-7:2007, EN 60079-15:2010, EN 60079-31:2009.
Marking code	Ⓔ II2GD / Ex db IIC / Ex eb IIC / Ex tb IIIC IP66
Zones & Use	Ⓔ II3G Ex nRc IIC Zones 1 & 2 ; Groups IIA, IIB and IIC ; for use "d", "e", "ia", "ib", "ic", "ma", "mb", "mo", "nA", "nC", "nR", "o", "pv", "px", "py", "pz" & "q". Zones 21 & 22 ; Groups IIIA, IIIB and IIIC ; for use "ib", "ic", "ia", "ib", "ma", "mb", "mc" & "p".
IECEx Standards	INERIS: IECEx INE 12.0025X IEC 60079-0:2011, IEC 60079-1:2007, IEC 60079-7:2006, IEC 60079-15:2010, IEC 60079-31:2008
Marking code	Ex db IIC / Ex eb IIC / Ex nRc IIC / Ex tb IIIC IP66
Other Ex Certificates	CEPEL (Inmetro): CEPEL 05.0558X GOST-R: POCC FR.ΓE05B03126 N°0422515 NEPSI: GYJ13.1082X
Shipping Certificates	ABS Manufacturing & Design Assessment P1836754-X & 10-HS 577243-PDA DNV Type Approval certificate N° E-10892 Lloyd's Type Approval certificate N° 11/00072
	cULus: E310130 UL 514B, UL 2225 and C22.2 No 1 with respect to the US National Electrical Code (NEC) and Canadian Electrical Code (CEC). Class I, Zone 2, AEx e II, Ex e II Hazardous Areas for use with unarmored ITC, MV, PLTC & TC cable. Allow installation in all gas atmospheres Article 505 of the NEC and section 18 of CEC.
	cULus: E314047 UL 514B, UL 2225 and C22.2 No 1 with respect to the US National Electrical Code (NEC) and Canadian Electrical Code (CEC). Class I, Zone 2, AEx e II, Ex e II Hazardous Areas for use with unarmored marine shipboard cable. Allow installation in all gas atmospheres Article 505 of the NEC and section 18 of CEC.

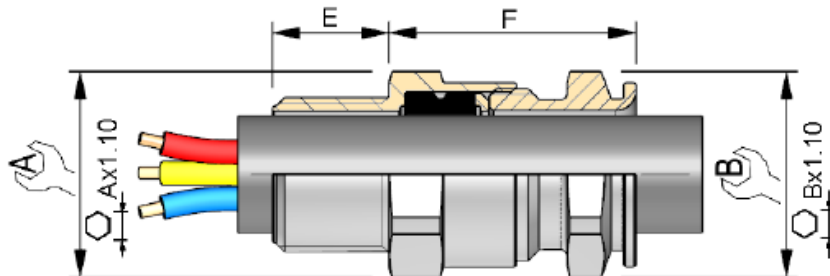

Reference CW614N/CR	Reference CW614N/ SI	Reference 316 L / CR	Reference 316 L / SI	ISO mini	ADE N°	Ø Externe Cable External Ø	A	B	E	F maxi
CAP806404V1	CAP806405V1	CAP806409V1	CAP806406V1	12*	4	4,5-8	17	17	15	25
CAP806594V1	CAP806595V1	CAP806599V1	CAP806596V1	16*	4	4,5-8,5	19	17	15	25
CAP806504V1	CAP806505V1	CAP806509V1	CAP806506V1	16*	5	7-12	19	19	15	27,5
CAP806664V1	CAP806665V1	CAP806669V1	CAP806666V1	20	3	2,75-5,5	24	15	15	24
CAP806674V1	CAP806675V1	CAP806679V1	CAP806676V1	20	4	4,5-8,5	24	17	15	25
CAP806694V1	CAP806695V1	CAP806699V1	CAP806696V1	20	5	7-12	24	19	15	27,5
CAP806604V1	CAP806605V1	CAP806609V1	CAP806606V1	20	6	10- 16	24	24	15	32
CAP806774V1	CAP806775V1	CAP806779V1	CAP806776V1	25	5	7-12	30	19	15	27,5
CAP806794V1	CAP806795V1	CAP806799V1	CAP806796V1	25	6	10-16	30	24	15	32
CAP806704V1	CAP806705V1	CAP806709V1	CAP806706V1	25	7	13,5-20,5	30	30	15	36,5
CAP806804V1	CAP806805V1	CAP806809V1	CAP806806V1	32	8	18-27,5	41	41	15	46
CAP806904V1	CAP806905V1	CAP806909V1	CAP806906V1	40	9	23-34	48	48	15	50
CAP807004V1	CAP807005V1	CAP807009V1	CAP807006V1	50	10	29-41	55	55	16	52
CAP807084V1	CAP807085V1	CAP807089V1	CAP807086V1	50	11	35-45	64	64	16	56,5
CAP807204V1	CAP807205V1	CAP807209V1	CAP807206V1	63	12	42-56	72	72	17	60
CAP807304V1	CAP807305V1	CAP807309V1	CAP807306V1	75	13	50-65	85	85	18	67,5
CAP807594V1	CAP807595V1	CAP807599V1	CAP807596V1	90	14	58-74	95	95	22	69
CAP807504V1	CAP807505V1	CAP807509V1	CAP807506V1	90	15	66-83	110	110	22	80
CAP807604V1	CAP807605V1	CAP807609V1	CAP807606V1	110	16	75- 93	120	120	22	80
CAP807704V1	CAP807705V1	CAP807709V1	CAP807706V1	110	17	85-104	135	135	22	90

*Non UL

4.3.4.2. Torque value

M16 Cable glands ADE N°5 :

Torque value for the cap = 12,5 N.m

Torque value for the connection module = 0,5 N.m

M20 Cable gland ADE N°6 :

Torque value for the cap = 20 N.m

Torque value for the connection module = 0,5 N.m

4.3.5. UL Electrical commissioning

	<p>The cables (Feedback or power cable) is a choice for end user and must be conform local state regulations.</p>
	<p>The end user will comply with local state regulations for his installation and he will make the UL certification for his installation</p>
	<p>The end user will determine which kind of connections and/ or conduits will be used.</p>
	<p><u>Warning</u> : Installers use any wiring other than that shown in the diagrams in §4.3.3. "Connection diagrams" at their own risk; Parker cannot be held responsible for unauthorized wiring. Make sure that the characteristics of the contactors shown in these diagrams are strictly followed according to the drive current</p>
	<p><u>CAUTION</u> : the drive associated with the motor must be outside the explosive area (hazardous area).</p>
	<p><u>Warning</u> : the conduit seal must be required within 18 inches of the motor.</p>



Connection of the UL motor:

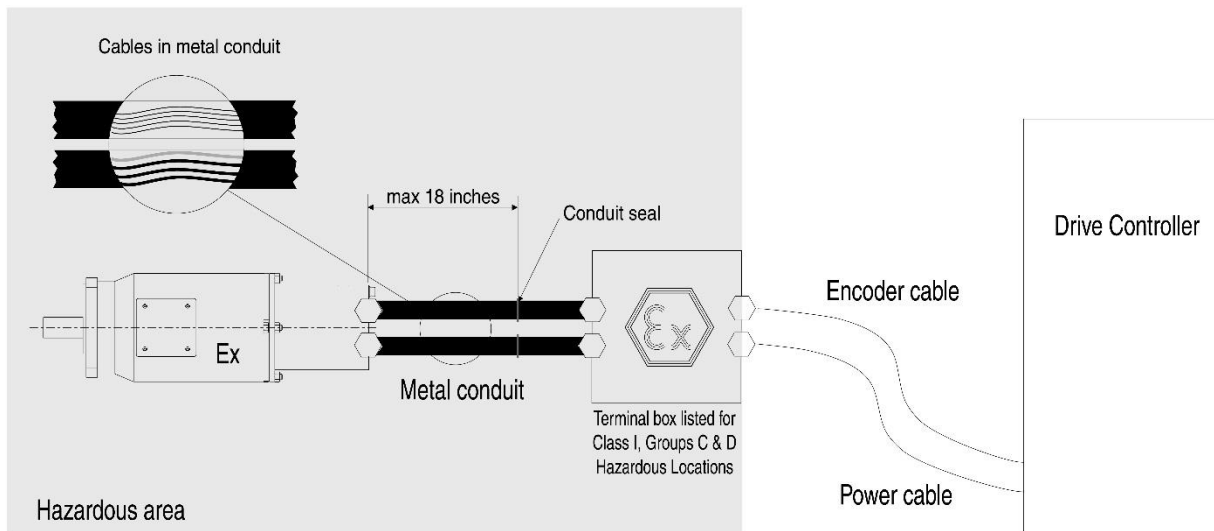



allowed Ex cable glands

Cable glands, metal pipes and terminal box not delivered

4.4. Maintenance Operations

4.4.1. Summary maintenance operations

	<p>Generality DANGER: The installation, commission and maintenance operations must be performed by qualified personnel, in conjunction with this documentation.</p> <p>The qualified personnel must know the safety (C18510 authorization, standard VDE 0105 or IEC 0364) and local regulations.</p> <p>They must be authorized to install, commission and operate in accordance with established practices and standards.</p> <p>Please contact PARKER for technical assistance.</p>
---	--

	<p>Danger: before any intervention the motor must be disconnected from te power supply. Due to the permanent magnets, a voltage is generated at the terminals when the motor shaft is turned</p>
---	--

Special requirements for ATEX servomotors

	<p>If a screw assembly of the enclosure need to be replaced, the new screw will must be quality 8.8 or higher for EX3-EX4-EX6 or quality 12.9 or higher for EX8. For the EX8 in UL version the screw must be quality 14.9 or higher.</p>
---	--

	<p>If the motor is used in dust explosive atmospheres, do not forget to do a regular cleaning in order to avoid the deposits of dusts.</p>
---	--

Operation	Periodicity
Clean the motor	Every year
Motor inspection (vibration changes, temperature changes, tightening torques on all scews)	Every year
Cable inspection, no degradation (colour, flexibility, cracks...)	Every year
Bearing replacement	Every 20 000h

4.4.2. Informations about the flameproof enclosure components

The Ex motors of Parker Hannifin France has a traceability on the flameproof enclosure components. It is forbidden to replace on of these components without consulting Parker Hannifin.

If a cover exchange between two identical motors is required, the customer must make a new traceability on these components. To make the traceability, the customer must refer to the number written on the cover.

4.4.3. ATEX flameproof joints informations ATEX/IECEx

In accordance with the standards for explosive atmospheres, find below the detail of the ATEX/IECEx flameproof joints

Size EX3 :

Flameproof joints	Joint length	Joint gap
Joint between the shaft and the housing	9,5 mm min	0,245 mm Max
Joint between the housing and the rear flange	13,4 mm min	0,177 mm Max
Joint between the rear flange and the cover	12,7 mm min	0,087 mm Max

Size EX4 :

Flameproof joints	Joint length	Joint gap
Joint between the shaft and the front flange	12,5 mm min	0,239 mm Max
Joint between the front flange and the housing	14,3 mm min	0,059 mm Max
Joint between the housing and the rear flange	12,9 mm min	0,069 mm Max
Joint between the rear flange and the cover	12,9 mm min	0,106 mm Max

Size EX6 :

Flameproof joints	Joint length	Joint gap
Joint between the shaft and the front flange	12,5 mm min	0,239 mm Max
Joint between the front flange and the housing	13,7 mm min	0,069 mm Max
Joint between the housing and the rear flange	13,4 mm min	0,069 mm Max
Joint between the rear flange and the cover	13,42 mm min	0,069 mm Max

Taille EX8 :

Flameproof joints	Joint length	Joint gap
Joint between the shaft and the front flange	12,5 mm min	0,178 mm Max
Joint between the front flange and the housing	12,7 mm min	0,079 mm Max
Joint between the housing and the rear flange	13,5 mm min	0,079 mm Max
Joint between the rear flange and the cover	14,1 mm min	0,146 mm Max

4.5. Troubleshooting

Some symptoms and their possible causes are listed below. This list is not comprehensive. Whenever an operating incident occurs, consult the relevant servo drive installation instructions (the troubleshooting display indications will help you in your investigation) or contact us at: <http://www.parker.com/eme/repairservice>.

You note that the motor does not turn by hand when the motor is not connected to the drive.	<ul style="list-style-type: none"> • Check there is no mechanical blockage or if the motor terminals are not short-circuited. • Check the power supply to the brake.
You have difficulty starting the motor or making it run	<ul style="list-style-type: none"> • Check on the fuses, the voltage at the terminals (there could be an overload or the bearings could be jammed), also checks on the load current. • Check the power supply to the brake (+ 24 V \pm 10 %) and its polarity. • Check on any thermal protection, its connection and how it is set in the drive. • Check on the servomotor insulation (if in doubt, carry out hot and cold measurements). <p>The minimum insulation resistance value measured under a max. 50V DC is 50 MΩ:</p> <ul style="list-style-type: none"> • Between the phase and the casing • Between the thermal protection and the casing • Between the brake coil and the casing • Between the resolver coils and the casing.
You find that the motor speed is drifting	<ul style="list-style-type: none"> • Reset the offset of the servoamplifier after having given a zero instruction to the speed setpoint input.
You notice that the motor is racing	<ul style="list-style-type: none"> • Check the speed setpoint of the servo drive. • Check you are well and truly in speed regulation (and not in torque regulation). • Check the encoder setting • Check on the servomotor phase order: U, V, W
You notice vibrations	<ul style="list-style-type: none"> • Check the encoder and tachometer connections, the earth connections (carefully) and the earthing of the earth wire, the setting of the servo drive speed loop, tachometer screening and filtering. • Check the stability of the secondary voltages. • Check the rigidity of the frame and motor support..
You think the motor is becoming unusually hot	<ul style="list-style-type: none"> • It may be overloaded or the rotation speed is too low : check the current and the operating cycle of the motor. • Check if the mounting surface is enough or if this surface is not a heat source – see §3.6 cooling. • Friction in the machine may be too high : <ul style="list-style-type: none"> - Test the motor current with and without a load. - Check the motor does not have thermal insulation. - Check that there is no friction from the brake when the brake power is on.
You find that the motor is too noisy	<p>Several possible explanations :</p> <ul style="list-style-type: none"> • Unsatisfactory mechanical balancing • There is friction from the brake: mechanical jamming. • Defective coupling • Loosening of several pieces • Poor adjustment of servo drive or position loop : check rotation in open loop